

---

## CONTENTS

|                                   |    |
|-----------------------------------|----|
| GENERAL INFORMATION               | 1  |
| BODY PANELS/EXHAUST SYSTEM        | 2  |
| MAINTENANCE                       | 3  |
| PGM-FI SYSTEM                     | 4  |
| IGNITION SYSTEM                   | 5  |
| ELECTRIC STARTER SYSTEM           | 6  |
| FUEL SYSTEM                       | 7  |
| LUBRICATION SYSTEM                | 8  |
| CYLINDER HEAD/VALVES              | 9  |
| CYLINDER/PISTON                   | 10 |
| CLUTCH/GEARSHIFT LINKAGE          | 11 |
| ALTERNATOR/STARTER CLUTCH         | 12 |
| CRANKCASE/TRANSMISSION/CRANKSHAFT | 13 |
| ENGINE REMOVAL/INSTALLATION       | 14 |
| FRONT WHEEL/SUSPENSION/STEERING   | 15 |
| REAR WHEEL/SUSPENSION             | 16 |
| HYDRAULIC BRAKE                   | 17 |
| BATTERY/CHARGING SYSTEM           | 18 |
| LIGHTS/METERS/SWITCHES            | 19 |
| WIRING DIAGRAMS                   | 20 |
| INDEX                             |    |

---

---

**MEMO**

---

## HOW TO USE THIS MANUAL

---

### A Few Words About Safety

#### Service Information

The service and repair information contained in this manual is intended for use by qualified, professional technicians. Attempting service or repairs without the proper training, tools, and equipment could cause injury to you or others. It could also damage the vehicle or create an unsafe condition.

This manual describes the proper methods and procedures for performing service, maintenance and repairs. Some procedures require the use of specially designed tools and dedicated equipment. Any person who intends to use a replacement part, service procedure or a tool that is not recommended by Honda, must determine the risks to their personal safety and the safe operation of the vehicle.

If you need to replace a part, use Genuine Honda parts with the correct part number or an equivalent part. We strongly recommend that you do not use replacement parts of inferior quality.

#### For Your Customer's Safety

Proper service and maintenance are essential to the customer's safety and the reliability of the vehicle. Any error or oversight while servicing a vehicle can result in faulty operation, damage to the vehicle, or injury to others.

#### **▲ WARNING**

Improper service and repairs can create an unsafe condition that can cause your customer to be seriously hurt or killed.

Follow the procedures and precautions in this manual and other service materials carefully.

#### For Your Safety

Because this manual is intended for the professional service technician, we do not provide warnings about many basic shop safety practices (e.g., Hot parts—wear gloves). If you have not received shop safety training or do not feel confident about your knowledge of safe servicing practice, we recommend that you do not attempt to perform the procedures described in this manual.

Some of the most important general service safety precautions are given below. However, we cannot warn you of every conceivable hazard that can arise in performing service and repair procedures. Only you can decide whether or not you should perform a given task.

#### **▲ WARNING**

Failure to properly follow instructions and precautions can cause you to be seriously hurt or killed.

Follow the procedures and precautions in this manual carefully.

#### Important Safety Precautions

Make sure you have a clear understanding of all basic shop safety practices and that you are wearing appropriate clothing and using safety equipment. When performing any service task, be especially careful of the following:

- Read all of the instructions before you begin, and make sure you have the tools, the replacement or repair parts, and the skills required to perform the tasks safely and completely.
- Protect your eyes by using proper safety glasses, goggles or face shields any time you hammer, drill, grind, pry or work around pressurized air or liquids, and springs or other stored-energy components. If there is any doubt, put on eye protection.
- Use other protective wear when necessary, for example gloves or safety shoes. Handling hot or sharp parts can cause severe burns or cuts. Before you grab something that looks like it can hurt you, stop and put on gloves.
- Protect yourself and others whenever you have the vehicle up in the air. Any time you lift the vehicle, either with a hoist or a jack, make sure that it is always securely supported. Use jack stands.

Make sure the engine is off before you begin any servicing procedures, unless the instruction tells you to do otherwise. This will help eliminate several potential hazards:

- Carbon monoxide poisoning from engine exhaust. Be sure there is adequate ventilation whenever you run the engine.
- Burns from hot parts or coolant. Let the engine and exhaust system cool before working in those areas.
- Injury from moving parts. If the instruction tells you to run the engine, be sure your hands, fingers and clothing are out of the way.

Gasoline vapors and hydrogen gases from batteries are explosive. To reduce the possibility of a fire or explosion, be careful when working around gasoline or batteries.

- Use only a nonflammable solvent, not gasoline, to clean parts.
  - Never drain or store gasoline in an open container.
  - Keep all cigarettes, sparks and flames away from the battery and all fuel-related parts.
-

## How To Use This Manual

This manual describes the service procedures for the GROM125.

Sections 1 and 3 apply to the whole vehicle. Section 2 illustrates procedures for removal/installation of components that may be required to perform service described in the following sections.

Section 4 through 20 describe parts of the motorcycle, grouped according to location.

Follow the Maintenance Schedule recommendations to ensure that the vehicle is in peak operating condition.

Performing the first scheduled maintenance is very important. It compensates for the initial wear that occurs during the break-in period.

Find the section you want on this page, then turn to the table of contents on the first page of the section.

Most sections start with an assembly or system illustration, service information and troubleshooting for the section. The subsequent pages give detailed procedure.

Your safety, and the safety of others, is very important. To help you make informed decisions we have provided safety messages and other information throughout this manual. Of course, it is not practical or possible to warn you about all the hazards associated with servicing this vehicle.

You must use your own good judgement.

You will find important safety information in a variety of forms including:

- Safety Labels – on the vehicle
- Safety Messages – preceded by a safety alert symbol  and one of three signal words, DANGER, WARNING, or CAUTION. These signal words mean:

** DANGER** You WILL be KILLED or SERIOUSLY HURT if you don't follow instructions.

** WARNING** You CAN be KILLED or SERIOUSLY HURT if you don't follow instructions.

** CAUTION** You CAN be HURT if you don't follow instructions.

- Instructions – how to service this vehicle correctly and safely.

As you read this manual, you will find information that is preceded by a **NOTICE** symbol. The purpose of this message is to help prevent damage to your vehicle, other property, or the environment.

ALL INFORMATION, ILLUSTRATIONS, DIRECTIONS AND SPECIFICATIONS INCLUDED IN THIS PUBLICATION ARE BASED ON THE LATEST PRODUCT INFORMATION AVAILABLE AT THE TIME OF APPROVAL FOR PRINTING. Honda Motor Co., Ltd. RESERVES THE RIGHT TO MAKE CHANGES AT ANY TIME WITHOUT NOTICE AND WITHOUT INCURRING ANY OBLIGATION WHATSOEVER. NO PART OF THIS PUBLICATION MAY BE REPRODUCED WITHOUT WRITTEN PERMISSION. THIS MANUAL IS WRITTEN FOR PERSONS WHO HAVE ACQUIRED BASIC KNOWLEDGE OF MAINTENANCE ON Honda MOTORCYCLES, MOTOR SCOOTERS OR ATVS.











© Honda Motor Co., Ltd.  
SERVICE PUBLICATION OFFICE

Date of Issue: August, 2013

## HOW TO USE THIS MANUAL

### SYMBOLS

The symbols used throughout this manual show specific service procedures. If supplementary information is required pertaining to these symbols, it would be explained specifically in the text without the use of the symbols.

|  |   |
|--|---|
|     | Replace the part(s) with <i>new</i> one(s) before assembly.   |
|     | Use the recommend engine oil, unless otherwise specified.   |
|     | Use molybdenum oil solution (mixture of the engine oil and molybdenum grease in a ratio of 1:1).  |
|     | Use multi-purpose grease (lithium based multi-purpose grease NLGI #2 or equivalent).  |
|     | Use molybdenum disulfide grease (containing more than 3% molybdenum disulfide, NLGI #2 or equivalent).<br>Example: <ul style="list-style-type: none"><li>• Molykote® BR-2 plus manufactured by Dow Corning U.S.A.</li><li>• Multi-purpose M-2 manufactured by Mitsubishi Oil, Japan</li></ul>   |
|     | Use molybdenum disulfide paste (containing more than 40% molybdenum disulfide, NLGI #2 or equivalent).<br>Example: <ul style="list-style-type: none"><li>• Molykote® G-n Paste manufactured by Dow Corning U.S.A.</li><li>• Honda Moly 60 (U.S.A. only)</li><li>• Rocol ASP manufactured by Rocol Limited, U.K.</li><li>• Rocol Paste manufactured by Sumico Lubricant, Japan</li></ul> |
|     | Use silicone grease.  |
|    | Apply a locking agent. Use a medium strength locking agent unless otherwise specified.  |
|   | Apply sealant.  |
|   | Use DOT 3 or DOT 4 brake fluid. Use the recommended brake fluid unless otherwise specified.   |
|  | Use fork or suspension fluid.   |

# 1. GENERAL INFORMATION

---

|                            |      |                                 |      |
|----------------------------|------|---------------------------------|------|
| SERVICE RULES .....        | 1-2  | LUBRICATION & SEAL POINTS ..... | 1-13 |
| MODEL IDENTIFICATION ..... | 1-3  | CABLE & HARNESS ROUTING .....   | 1-15 |
| SPECIFICATIONS .....       | 1-5  | TECHNICAL FEATURES .....        | 1-23 |
| TORQUE VALUES .....        | 1-10 | EMISSION CONTROL SYSTEMS .....  | 1-25 |

## GENERAL INFORMATION

---

### SERVICE RULES

1. Use Honda genuine or Honda-recommended parts and lubricants or their equivalents. Parts that do not meet Honda's design specifications may cause damage to the motorcycle.
2. Use the special tools designed for this product to avoid damage and incorrect assembly.
3. Use only metric tools when servicing the motorcycle. Metric bolts, nuts and screws are not interchangeable with English fasteners.
4. Install new gaskets, O-rings, cotter pins, and lock plates when reassembling.
5. When tightening bolts or nuts, begin with the larger diameter or inner bolt first. Then tighten to the specified torque diagonally in incremental steps unless a particular sequence is specified.
6. Clean parts in cleaning solvent upon disassembly. Lubricate any sliding surfaces before reassembly.
7. After reassembly, check all parts for proper installation and operation.
8. Route all electrical wires as shown in the Cable and Harness Routing (page 1-15).
9. Do not bend or twist control cables. Damaged control cables will not operate smoothly and may stick or bind.

### ABBREVIATION

Throughout this manual, the following abbreviations are used to identify the respective parts or systems.

| Abbrev. term  | Full term                       |
|---------------|---------------------------------|
| CKP sensor    | Crankshaft Position sensor      |
| DLC           | Data Link Connector             |
| DTC           | Diagnostic Trouble Code         |
| ECM           | Engine Control Module           |
| EOT sensor    | Engine Oil Temperature sensor   |
| IAT sensor    | Intake Air Temperature sensor   |
| MIL           | Malfunction Indicator Lamp      |
| MCS           | Motorcycle Communication System |
| PGM-FI        | Programmed Fuel Injection       |
| SCS connector | Service Check Short connector   |
| TP sensor     | Throttle Position sensor        |
| VS sensor     | Vehicle Speed sensor            |

### DESTINATION CODE

Throughout this manual, the following codes are used to identify individual types for each region.

| DESTINATION CODE | REGION                    |
|------------------|---------------------------|
| AC               | 50 STATE meets California |
| CM               | Canada                    |

MODEL IDENTIFICATION



## GENERAL INFORMATION

### SERIAL NUMBERS AND LABELS

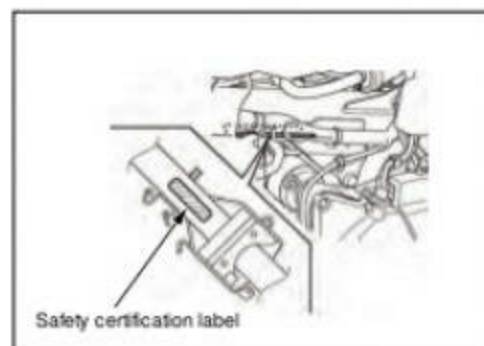
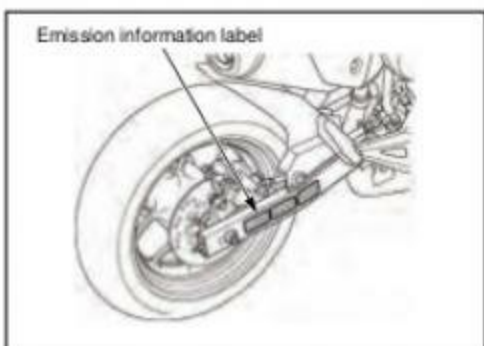
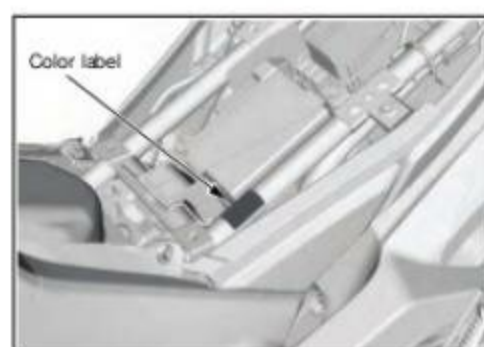
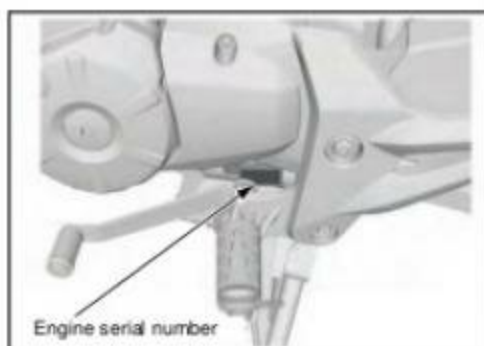
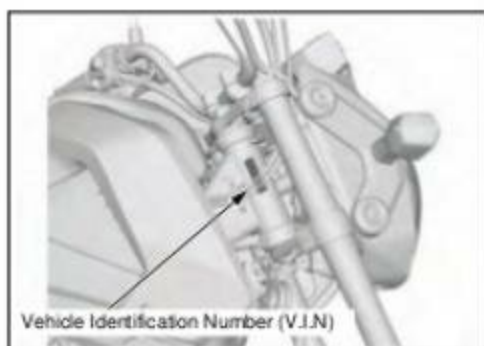

## SPECIFICATIONS

## GENERAL SPECIFICATIONS

| ITEM                 |                         | SPECIFICATION  |  |
|----------------------|-------------------------|--|--|
| DIMENSIONS           | Overall length          | 1,760 mm (69.3 in)   |  |
|                      | Overall width           | 755 mm (29.7 in)   |  |
|                      | Overall height          | 1,010 mm (39.8 in)   |  |
|                      | Wheelbase               | 1,200 mm (47.2 in)   |  |
|                      | Seat height             | 765 mm (30.1 in)   |  |
|                      | Footpeg height          | 286 mm (11.3 in)   |  |
|                      | Ground clearance        | 160 mm (6.3 in)  |  |
|                      | Curb weight             | 102 kg (225 lbs)   |  |
|                      | Maximum weight capacity | 140 kg (309 lbs)   |  |
| FRAME                | Frame type              | Back bone type   |  |
|                      | Front suspension        | Telescopic fork  |  |
|                      | Front axle travel       | 100 mm (3.9 in)  |  |
|                      | Rear suspension         | Swingarm   |  |
|                      | Rear axle travel        | 103 mm (4.1 in)  |  |
|                      | Tire size               | Front<br>120/70-12 51L<br>Rear<br>130/70-12 56L  |  |
|                      | Tire brand              | Front<br>V119C (VEE RUBBER)<br>Rear<br>V119C (VEE RUBBER)                                    |  |
|                      | Front brake             | Hydraulic single disc  |  |
|                      | Rear brake              | Hydraulic single disc  |  |
|                      | Caster angle            | 25° 00'  |  |
|                      | Trail length            | 81 mm (3.2 in)   |  |
|                      | Fuel tank capacity      | 5.5 liters (1.45 US gal, 1.21 Imp gal)   |  |
|                      | ENGINE                  | Cylinder arrangement   | Single cylinder inclined 80° from vertical |
|                      |                         | Bore and stroke  | 52.4 x 57.9 mm (2.06 - 2.28 in)            |
| Displacement         |                         | 124.9 cm <sup>3</sup>  |  |
| Compression ratio    |                         | 9.3:1  |  |
| Valve train          |                         | Chain driven, OHC  |  |
| Intake valve         |                         | opens at 1.0 mm lift<br>closes at 1.0 mm lift  |  |
| Exhaust valve        |                         | opens at 1.0 mm lift<br>closes at 1.0 mm lift  |  |
| Lubrication system   |                         | Forced pressure and wet sump   |  |
| Oil pump type        |                         | Trochoid   |  |
| Cooling system       |                         | Air cooled   |  |
| Air filtration       |                         | Viscous paper element  |  |
| Engine dry weight    | 23.4 kg (52 lbs)        |  |  |
| FUEL DELIVERY SYSTEM | Type                    | PGM-FI   |  |
|                      | Throttle bore           | 24 mm (1.06 in)  |  |
| DRIVE TRAIN          | Clutch system           | Multi-plate, wet   |  |
|                      | Clutch operation system | Cable operating  |  |
|                      | Transmission            | Constant mesh, 4 speeds  |  |
|                      | Primary reduction       | 3.350 (67/20)  |  |
|                      | Final reduction         | 2.266 (34/15)  |  |
|                      | Gear ratio              | 1st<br>2.500 (35/14)<br>2nd<br>1.550 (31/20)<br>3rd<br>1.150 (23/20)<br>4th<br>0.923 (24/26) |  |
|                      | Gearshift pattern       | Left foot operated return system,<br>1 - N - 2 - 3 - 4                                       |  |
| ELECTRICAL           | Ignition system         | Computer-controlled digital transistorized with electric advance                             |  |
|                      | Starting system         | Electric starter motor   |  |
|                      | Charging system         | Single phase output alternator   |  |
|                      | Regulator/rectifier     | SCR opened, single phase half-wave rectification   |  |
|                      | Lighting system         | Alternator   |  |

## GENERAL INFORMATION

### PGM-FI SYSTEM SPECIFICATIONS

| ITEM                     |               | SPECIFICATIONS                      |
|--------------------------|---------------|-------------------------------------|
| Engine idle speed        |               | 1,400 ± 100 min <sup>-1</sup> (rpm) |
| IAT sensor resistance    | (40°C/104°F)  | 21.2 – 16.4 kΩ                      |
| EOT sensor resistance    | (20°C/68°F)   | 2.5 – 2.8 kΩ                        |
|                          | (100°C/212°F) | 0.21 – 0.22 kΩ                      |
| Fuel injector resistance | (20°C/68°F)   | 11 – 13 Ω                           |

### IGNITION SYSTEM SPECIFICATIONS

| ITEM                       |          | SPECIFICATIONS                |                 |
|----------------------------|----------|-------------------------------|-----------------|
| Spark plug                 | Standard | CPR6EA-9 (NGK)                | U20EPR9 (DENSO) |
|                            | Optional | CPR7EA-9 (NGK)                | U22EPR9 (DENSO) |
| Spark plug gap             |          | 0.8 – 0.9 mm (0.03 – 0.04 in) |                 |
| Ignition coil peak voltage |          | 100 V minimum                 |                 |
| CKP sensor peak voltage    |          | 0.7 V minimum                 |                 |
| Ignition timing            |          | 12° BTDC at idle speed        |                 |

### ELECTRIC STARTER SYSTEM SPECIFICATIONS

| ITEM                       | STANDARD                | Unit: mm (in) |               |
|----------------------------|-------------------------|---------------|---------------|
|                            |                         | STANDARD      | SERVICE LIMIT |
| Starter motor brush length | 6.7 – 7.3 (0.26 – 0.29) |               | 3.5 (0.14)    |

### FUEL SYSTEM SPECIFICATIONS

| ITEM                                | SPECIFICATIONS  |
|-------------------------------------|---|
| Throttle body identification number | GQY9A   |
| Idle air screw standard opening     | 2 turns out from the fully seated position                    |
| Throttle grip freeplay              | 2 – 6 mm (0.08 – 0.24 in)                                     |
| Fuel pressure at idle               | 270 – 323 kPa (2.75 – 3.29 kgf/cm <sup>2</sup> , 39 – 47 psi) |
| Fuel pump flow (at 12 V)            | 162 cm <sup>3</sup> minimum/10 seconds                        |

### LUBRICATION SYSTEM SPECIFICATIONS

| ITEM                   |                | Unit: mm (in)   |               |
|------------------------|----------------|---|---------------|
|                        |                | STANDARD  | SERVICE LIMIT |
| Engine oil capacity    | At draining    | 0.9 liter (0.96 US Qt, 0.20 Imp gal)  |               |
|                        | At disassembly | 1.1 liters (1.16 US Qt, 0.24 Imp gal)   |               |
| Recommended engine oil |                | Pro Honda GN4 4-stroke oil (U.S.A. & Canada) or equivalent motorcycle oil<br>API service classification: SG or higher (except oils labeled as energy conserving on the circular API service label)<br>JASO T903 standard: MA<br>Viscosity: SAE 10W-30 |               |
| Oil pump rotor         | Tip clearance  |   | 0.15 (0.006)  |
|                        | Body clearance | 0.15 0.21 (0.006 – 0.008)   | 0.26 (0.010)  |
|                        | Side clearance | 0.03 0.09 (0.001 – 0.004)   | 0.15 (0.006)  |

## CYLINDER HEAD/VALVES SPECIFICATIONS

Unit: mm (in)

| ITEM                     |                         |            | STANDARD  | SERVICE LIMIT  |
|--------------------------|-------------------------|------------|---|----------------|
| Cylinder compression     |                         |            | 1.1 MPa (11.2 kgf/cm <sup>2</sup> , 160 psi) at 600 min <sup>-1</sup> (rpm) | —              |
| Cylinder head warpage    |                         |            | —   | 0.05 (0.002)   |
| Camshaft                 | Cam lobe height         | IN         | 32.657 – 32.897 (1.2857 - 1.2952)   | 32.33 (1.2728) |
|                          |                         | EX         | 32.481 – 32.721 (1.2788 - 1.2882)   | 31.78 (1.2512) |
| Valve, valve guide       | Valve clearance         | IN         | 0.10 ± 0.02 (0.004 ± 0.001)   | —              |
|                          |                         | EX         | 0.17 ± 0.02 (0.007 ± 0.001)   | —              |
|                          | Valve stem O.D.         | IN         | 4.975 – 4.990 (0.1959 - 0.1965)   | 4.965 (0.1955) |
|                          |                         | EX         | 4.955 – 4.970 (0.1951 - 0.1957)   | 4.945 (0.1947) |
|                          | Valve guide I.D.        | IN/EX      | 5.000 – 5.012 (0.1969 - 0.1973)   | 5.03 (0.198)   |
|                          | Stem-to-guide clearance | IN         | 0.010 – 0.037 (0.0004 - 0.0015)   | 0.065 (0.003)  |
|                          |                         | EX         | 0.030 – 0.057 (0.0012 - 0.0022)   | 0.085 (0.003)  |
|                          | Valve guide projection  | IN/EX      | 10.1 – 10.3 (0.40 - 0.41)   | —              |
| Valve seat width         | IN/EX                   | 1.0 (0.04) | 1.6 (0.06)  |                |
| Valve spring free length |                         |            | 33.14 (1.305)   | 31.5 (1.240)   |
| Cam chain tensioner      | Push rod O.D.           |            | 11.985 – 12.000 (0.4718 - 0.4724)   | 11.94 (0.470)  |
|                          | Spring free length      |            | 111.3 (4.38)  | 109 (4.29)     |

## CYLINDER/PISTON SPECIFICATIONS

Unit: mm (in)

| ITEM                                   |  |                 | STANDARD                          | SERVICE LIMIT                   |                |
|--|--|-----------------|-----------------------------------|---------------------------------|----------------|
| Cylinder                               | I.D.   |                 | 52.405 – 52.415 (2.0632 - 2.0636) | 52.445 (2.0648)                 |                |
|  | Out-of-round                                   |                 | —                                 | 0.10 (0.004)                    |                |
|  | Taper  |                 | —                                 | 0.10 (0.004)                    |                |
|  | Warpage  |                 | —                                 | 0.05 (0.002)                    |                |
| Piston, piston rings, piston pin       | Piston O.D.                                    |                 | 52.380 – 52.395 (2.0622 - 2.0628) | 52.310 (2.0594)                 |                |
|  | Piston O.D. measurement point                  |                 | 10 mm from bottom of skirt        | —                               |                |
|  | Piston pin bore I.D.                           |                 | 13.002 – 13.008 (0.5119 - 0.5121) | 13.03 (0.5130)                  |                |
|  | Piston pin O.D.                                |                 | 12.994 – 13.000 (0.5116 - 0.5118) | 12.98 (0.5110)                  |                |
|  | Piston-to-piston pin clearance                 |                 | 0.002 – 0.014 (0.0001 - 0.0005)   | 0.05 (0.002)                    |                |
|  | Piston ring-to-ring groove clearance (RIKEN)   | Top             |                                   | 0.030 – 0.065 (0.0012 - 0.0026) | 0.100 (0.0039) |
|  |  | Second          |                                   | 0.015 – 0.050 (0.0006 - 0.0020) | 0.090 (0.0035) |
|  | Piston ring-to-ring groove clearance (TEIKOKU) | Top             |                                   | 0.015 – 0.050 (0.0006 - 0.0020) | 0.090 (0.0035) |
|  |  | Second          |                                   | 0.015 – 0.050 (0.0006 - 0.0020) | 0.090 (0.0035) |
|  | Piston ring end gap (RIKEN)                    | Top             |                                   | 0.10 – 0.25 (0.004 - 0.010)     | 0.50 (0.020)   |
|  |  | Second          |                                   | 0.10 – 0.30 (0.004 - 0.012)     | 0.60 (0.024)   |
|  |  | Oil (side rail) |                                   | 0.20 – 0.70 (0.008 - 0.028)     | 1.10 (0.043)   |
| Piston ring end gap (TEIKOKU)          | Top  |                 | 0.10 – 0.25 (0.004 - 0.010)       | 0.50 (0.020)                    |                |
|  | Second   |                 | 0.35 – 0.50 (0.014 - 0.020)       | 0.75 (0.030)                    |                |
|  | Oil (side rail)                                |                 | 0.10 – 0.35 (0.004 - 0.014)       | 1.10 (0.043)                    |                |
| Cylinder-to-piston clearance           |  |                 | 0.010 – 0.035 (0.0004 - 0.0014)   | 0.10 (0.004)                    |                |
| Connecting rod small end I.D.          |  |                 | 13.010 – 13.028 (0.5122 - 0.5129) | 13.05 (0.514)                   |                |
| Connecting rod-to-piston pin clearance |  |                 | 0.010 – 0.034 (0.0004 - 0.0013)   | 0.07 (0.003)                    |                |

## GENERAL INFORMATION

### CLUTCH/GEARSHIFT LINKAGE SPECIFICATIONS

Unit: mm (in)

| ITEM                                 |                           | STANDARD                          | SERVICE LIMIT                     |                 |
|--------------------------------------|---------------------------|-----------------------------------|-----------------------------------|-----------------|
| Manual clutch                        | Disc thickness            | 2.50 – 2.70 (0.099 - 0.106)       | 2.2 (0.09)                        |                 |
|                                      | Plate warpage             | –                                 | 0.20 (0.008)                      |                 |
|                                      | Clutch spring free length | 27.4 (1.08)                       | –                                 |                 |
|                                      | Clutch outer I.D.         | 23.000 – 23.013 (0.9055 - 0.9060) | 23.06 (0.908)                     |                 |
|                                      | Clutch outer guide        | I.D.                              | 16.991 – 17.009 (0.6689 - 0.6696) | 17.049 (0.6712) |
|                                      |                           | O.D.                              | 22.959 – 22.980 (0.9039 - 0.9047) | 22.940 (0.9031) |
| Mainshaft O.D. at clutch outer guide |                           | 16.966 – 16.984 (0.6680 - 0.6687) | 16.87 (0.66)                      |                 |

### ALTERNATOR/STARTER CLUTCH SPECIFICATIONS

Unit: mm (in)

| ITEM                          | STANDARD                          | SERVICE LIMIT   |
|-------------------------------|-----------------------------------|-----------------|
| Starter driven gear boss O.D. | 45.660 – 45.673 (1.7976 - 1.7981) | 45.642 (1.7969) |

### CRANKCASE/TRANSMISSION/CRANKSHAFT SPECIFICATIONS

Unit: mm (in)

| ITEM                      |                                 | STANDARD                          | SERVICE LIMIT                     |               |
|---------------------------|---------------------------------|-----------------------------------|-----------------------------------|---------------|
| Crankshaft                | Connecting rod side clearance   | 0.10 – 0.35 (0.004 - 0.0138)      | 0.60 (0.024)                      |               |
|                           | Connecting rod radial clearance | 0.004 – 0.016 (0.0002 - 0.0006)   | 0.05 (0.002)                      |               |
|                           | Runout                          | –                                 | 0.10 (0.004)                      |               |
| Transmission              | Gear I.D.                       | M2, M3                            | 17.000 – 17.018 (0.6693 - 0.6700) | 17.04 (0.671) |
|                           |                                 | C1                                | 18.000 – 18.018 (0.7087 - 0.7094) | 18.04 (0.710) |
|                           |                                 | C4                                | 20.000 – 20.021 (0.7874 - 0.7882) | 20.04 (0.789) |
|                           | Bushing O.D.                    | C1                                | 17.966 – 17.984 (0.7073 - 0.7080) | 17.94 (0.706) |
|                           | Bushing I.D.                    | C1                                | 15.000 – 15.018 (0.5906 - 0.5913) | 15.04 (0.592) |
|                           | Gear-to-bushing clearance       | C1                                | 0.016 – 0.052 (0.0006 - 0.0020)   | 0.10 (0.004)  |
|                           | Mainshaft O.D.                  | at M3                             | 16.966 – 16.984 (0.6680 - 0.6687) | 16.95 (0.667) |
|                           | Countershaft O.D.               | at C1 bushing                     | 14.966 – 14.984 (0.5892 - 0.5899) | 14.95 (0.589) |
|                           | Gear-to-shaft clearance         | M3                                | 0.016 – 0.052 (0.0006 - 0.0020)   | 0.09 (0.004)  |
|                           | Bushing-to-shaft clearance      | C1                                | 0.016 – 0.052 (0.0006 - 0.0020)   | 0.09 (0.004)  |
| Shift fork/<br>Shift drum | Shift fork I.D.                 | 10.000 – 10.018 (0.3937 - 0.3944) | 10.07 (0.397)                     |               |
|                           | Shift fork claw thickness       | 4.93 – 5.00 (0.194 - 0.197)       | 4.90 (0.193)                      |               |
|                           | Shift fork shaft O.D.           | 9.986 – 9.995 (0.3931 - 0.3935)   | 9.93 (0.391)                      |               |
|                           | Shift drum journal I.D.         | Left                              | 24.000 – 24.033 (0.9449 - 0.9462) | 24.07 (0.948) |
| Right                     |                                 | 28.000 – 28.021 (1.1024 - 1.1032) | 28.08 (1.106)                     |               |

### FRONT WHEEL/SUSPENSION/STEERING SPECIFICATIONS

Unit: mm (in)

| ITEM                     |                        | STANDARD                                    | SERVICE LIMIT |
|--------------------------|------------------------|---|---------------|
| Minimum tire tread depth |                        | –   | To indicator  |
| Cold tire pressure       | Driver only            | 200 kPa (2.00 kgf/cm <sup>2</sup> , 29 psi) | –             |
|                          | Driver and passenger   | 200 kPa (2.00 kgf/cm <sup>2</sup> , 29 psi) | –             |
| Axle runout              |                        | –   | 0.2 (0.01)    |
| Wheel rim runout         | Radial                 | –   | 2.0 (0.08)    |
|                          | Axial                  | –   | 2.0 (0.08)    |
| Fork                     | Pipe runout            | –   | 0.20 (0.010)  |
|                          | Recommended fork fluid | Pro Honda Suspension Fluid SS-8 (10W)       | –             |
|                          | Fluid level            | 75 (2.95)                                   | –             |
|                          | Fluid capacity         | 221.0 ± 1.5 cm <sup>3</sup>                 | –             |

## REAR WHEEL/SUSPENSION SPECIFICATIONS

Unit: mm (in)

| ITEM                     |                      | STANDARD                                    | SERVICE LIMIT |
|--------------------------|----------------------|---|---------------|
| Minimum tire tread depth |                      | -   | To indicator  |
| Cold tire pressure       | Driver only          | 200 kPa (2.00 kgf/cm <sup>2</sup> , 29 psi) | -             |
|                          | Driver and passenger | 200 kPa (2.00 kgf/cm <sup>2</sup> , 29 psi) | -             |
| Axle runout              |                      | -   | 0.2 (0.01)    |
| Wheel rim runout         | Radial               | -   | 2.0 (0.08)    |
|                          | Axial                | -   | 2.0 (0.08)    |
| Drive chain              | Size/link            | 420/106                                     | -             |
|                          | Slack                | 30 - 40 (1.2 - 1.6)                         | -             |

## HYDRAULIC BRAKE SPECIFICATIONS

Unit: mm (in)

| ITEM  |                          | STANDARD                          | SERVICE LIMIT   |
|-------|--------------------------|-----------------------------------|-----------------|
| Front | Specified brake fluid    | Honda DOT 4 brake fluid           | -               |
|       | Brake pad wear indicator | -                                 | To groove       |
|       | Brake disc thickness     | 3.3 - 3.7 (0.13 - 0.15)           | 3.0 (0.12)      |
|       | Brake disc warpage       | -                                 | 0.30 (0.012)    |
|       | Master cylinder I.D.     | 12.700 - 12.743 (0.5000 - 0.5017) | 12.755 (0.5022) |
|       | Master piston O.D.       | 12.657 - 12.684 (0.4983 - 0.4994) | 12.640 (0.4976) |
|       | Caliper cylinder I.D.    | 25.400 - 25.450 (1.0000 - 1.0020) | 25.460 (1.0024) |
|       | Caliper piston O.D.      | 25.318 - 25.368 (0.9968 - 0.9987) | 25.310 (0.9965) |
| Rear  | Specified brake fluid    | DOT 3 or DOT 4                    | -               |
|       | Brake pad wear indicator | -                                 | To groove       |
|       | Brake disc thickness     | 3.8 - 4.2 (0.15 - 0.17)           | 3.5 (0.14)      |
|       | Brake disc warpage       | -                                 | 0.30 (0.011)    |
|       | Master cylinder I.D.     | 14.000 - 14.043 (0.5512 - 0.5529) | -               |
|       | Master piston O.D.       | 13.957 - 13.984 (0.5495 - 0.5506) | -               |
|       | Caliper cylinder I.D.    | 27.000 - 27.050 (1.0630 - 1.0650) | -               |
|       | Caliper piston O.D.      | 26.935 - 26.968 (1.0604 - 1.0617) | -               |

## BATTERY/CHARGING SYSTEM SPECIFICATIONS

| ITEM             |                                      | SPECIFICATIONS                        |               |
|------------------|--------------------------------------|---------------------------------------|---------------|
| Battery          | Type                                 | YT25S                                 |               |
|                  | Capacity                             | 12 V - 3.5 Ah (10 HR)                 |               |
|                  | Current leakage                      | 0.01 mA                               |               |
|                  | Voltage<br>(20°C/68°F)               | Fully charged                         | 13.0 - 13.2 V |
|                  |                                      | Needs charging                        | Below 12.4 V  |
| Charging current | Normal                               | 0.5 A/5 - 10 h                        |               |
|                  | Quick                                | 2.5 A/1 h                             |               |
| Alternator       | Capacity                             | 0.18 kW/5,000 min <sup>-1</sup> (rpm) |               |
|                  | Charging coil resistance (20°C/68°F) | 0.2 - 1.0 Ω                           |               |

## LIGHTS/METERS/SWITCHES SPECIFICATIONS

| ITEM                |                       | SPECIFICATION  |                   |
|---------------------|-----------------------|----------------|-------------------|
| Bulbs               | Headlight (High/Low)  | 12 V - 35/35 W |                   |
|                     | Brake/tail light      | LED            |                   |
|                     | Turn signal light     | Front          | 12 V - 21/5 W x 2 |
|                     |                       | Rear           | 12 V - 21 W x 2   |
|                     | License light         | 12 V - 5 W     |                   |
|                     | Meter light           | LED            |                   |
|                     | Turn signal indicator | LED            |                   |
| High beam indicator | LED                   |                |                   |
| Neutral indicator   | LED                   |                |                   |
| Fuse                | Main fuse             | 15 A           |                   |
|                     | Sub fuse              | 10 A           |                   |

## GENERAL INFORMATION

# TORQUE VALUES

## STANDARD TORQUE VALUES

| FASTENER TYPE                                 | TORQUE<br>N·m (kgf·m, lbf·ft) | FASTENER TYPE             | TORQUE<br>N·m (kgf·m, lbf·ft) |
|---|-------------------------------|---------------------------|-------------------------------|
| 5 mm bolt and nut                             | 5.2 (0.5, 3.8)                | 5 mm screw                | 4.2 (0.4, 3.1)                |
| 6 mm bolt and nut<br>(Include SH flange bolt) | 10 (1.0, 7)                   | 6 mm screw                | 9.0 (0.9, 6.6)                |
| 8 mm bolt and nut                             | 22 (2.2, 16)                  | 6 mm flange bolt          | 12 (1.2, 9)                   |
| 10 mm bolt and nut                            | 34 (3.5, 25)                  | (Include NSHF) and nut    |                               |
| 12 mm bolt and nut                            | 54 (5.5, 40)                  | 8 mm flange bolt and nut  | 27 (2.8, 20)                  |
|   |                               | 10 mm flange bolt and nut | 39 (4.0, 29)                  |

## ENGINE & FRAME TORQUE VALUES

- Torque specifications listed below are for important fasteners.
- Others should be tightened to standard torque values listed above.

### BODY PANELS/EXHAUST SYSTEM

| ITEM                                    | Q'TY | THREAD<br>DIA. (mm) | TORQUE<br>N·m (kgf·m, lbf·ft) | REMARKS                             |
|---|------|---------------------|-------------------------------|-------------------------------------|
| Body cover and tailcover mounting screw | 4    | 4                   | 0.9 (0.1, 0.7)                |                                     |
| Exhaust pipe cover bolt                 | 2    | 6                   | 14 (1.4, 10)                  |                                     |
| Exhaust pipe mounting nut               | 2    | 8                   | 27 (2.8, 20)                  |                                     |
| Exhaust pipe mounting bolt              | 1    | 8                   | 27 (2.8, 20)                  |                                     |
| Exhaust pipe stud bolt                  | 2    | 8                   | —                             | See page 2-10                       |
| Front fender mounting bolt              | 6    | 6                   | 12 (1.2, 9)                   |                                     |
| Front cowl mounting bolt                | 4    | 6                   | 12 (1.2, 9)                   |                                     |
| Muffler band bolt                       | 1    | 8                   | 20 (2.0, 15)                  |                                     |
| Muffler mounting bolt                   | 1    | 8                   | 27 (2.8, 20)                  |                                     |
| Muffler mounting nut                    | 1    | 8                   | 27 (2.8, 20)                  |                                     |
| Muffler protector bolt                  | 1    | 6                   | 14 (1.4, 10)                  |                                     |
| Rear fender stay bolt                   | 2    | 8                   | 31 (3.2, 23)                  |                                     |
| Seat lock bracket bolt                  | 2    | 6                   | 14 (1.4, 10)                  |                                     |
| Shroud screw                            | 3    | 5                   | 4.2 (0.4, 3.1)                |                                     |
| Shroud tapping screw                    | 20   | 4                   | 0.9 (0.1, 0.7)                |                                     |
| Sidestand lock nut                      | 1    | 10                  | 30 (3.1, 22)                  | U-nut                               |
| Sidestand pivot bolt                    | 1    | 10                  | 10 (1.0, 7)                   |                                     |
| Sidestand switch bolt                   | 1    | 6                   | 10 (1.0, 7)                   | A/LOC bolt; replace with a new one. |

### MAINTENANCE

| ITEM                      | Q'TY | THREAD<br>DIA. (mm) | TORQUE<br>N·m (kgf·m, lbf·ft) | REMARKS |
|---------------------------|------|---------------------|-------------------------------|---------|
| Air cleaner cover screw   | 8    | 5                   | 1.1 (0.1, 0.8)                |         |
| Air cleaner element screw | 1    | 5                   | 1.1 (0.1, 0.8)                |         |
| Spark plug                | 1    | 10                  | 16 (1.6, 12)                  |         |
| Crankshaft hole cap       | 1    | 30                  | 8.0 (0.8, 5.9)                |         |
| Oil drain bolt            | 1    | 12                  | 24 (2.4, 18)                  |         |

### PGM-FI SYSTEM

| ITEM                              | Q'TY | THREAD<br>DIA. (mm) | TORQUE<br>N·m (kgf·m, lbf·ft) | REMARKS  |
|-----------------------------------|------|---------------------|-------------------------------|--|
| Bank angle sensor mounting nut    | 2    | 6                   | 10 (1.0, 7)                   |  |
| Fuel injector joint mounting bolt | 2    | 5                   | 12 (1.2, 9)                   |  |
| EOT sensor                        | 1    | 10                  | 14.5 (1.5, 11)                | Apply engine oil to the threads and seating surface. |
| O <sub>2</sub> sensor             | 1    | 12                  | 24.5 (2.5, 18)                |  |

## LUBRICATION SYSTEM

| ITEM                              | QTY | THREAD DIA. (mm) | TORQUE N·m (kgf·m, lbf·ft) | REMARKS                             |
|-----------------------------------|-----|------------------|----------------------------|-------------------------------------|
| Oil centrifugal filter cover bolt | 3   | 6                | 12 (1.2, 9)                | Apply locking agent to the threads. |
| Oil pump assembly bolt            | 2   | 5                | 5.2 (0.5, 3.8)             |                                     |

## FUEL SYSTEM

| ITEM                                | QTY | THREAD DIA. (mm) | TORQUE N·m (kgf·m, lbf·ft) | REMARKS                              |
|-------------------------------------|-----|------------------|----------------------------|--------------------------------------|
| Fuel filter stay nut                | 2   | 6                | 12 (1.2, 9)                | For tightening sequence See page 7-5 |
| Fuel pump setting plate nut         | 2   | 6                | 12 (1.2, 9)                |                                      |
| Fuel pump setting plate special nut | 2   | 6                | 12 (1.2, 9)                |                                      |
| Throttle cable stay screw           | 1   | 5                | 3.4 (0.3, 2.5)             |                                      |
| Connecting hose band screw          | 1   | 4                | 1.5 (0.2, 1.1)             |                                      |

## ENGINE REMOVAL/INSTALLATION

| ITEM                             | QTY     | THREAD DIA. (mm) | TORQUE N·m (kgf·m, lbf·ft) | REMARKS      |
|----------------------------------|---------|------------------|----------------------------|--------------|
| Engine hanger nut                | (upper) | 1                | 10                         | 54 (5.5, 40) |
|                                  | (lower) | 1                | 10                         | 54 (5.5, 40) |
|                                  | (front) | 1                | 10                         | 54 (5.5, 40) |
| Drive sprocket fixing plate bolt | 2       | 6                | 12 (1.2, 9)                |              |
| Step holder mounting bolt        | 2       | 8                | 31 (3.2, 23)               |              |

## CYLINDER HEAD/VALVES

| ITEM                                    | QTY | THREAD DIA. (mm) | TORQUE N·m (kgf·m, lbf·ft) | REMARKS  |
|---|-----|------------------|----------------------------|--|
| Cylinder head cap bolt                  | 4   | 8                | 24 (2.4, 18)               | Apply engine oil to the threads and seating surface. |
| Cam sprocket bolt                       | 1   | 8                | 27 (2.8, 20)               | Apply engine oil to the threads and seating surface. |
| Tappet adjust nut                       | 2   | 5                | 9.0 (0.9, 6.6)             | Apply engine oil to the threads and seating surface. |
| Cam chain tensioner sealing bolt        | 1   | 14               | 22 (2.2, 16)               |  |
| Cam chain tensioner arm pivot bolt      | 1   | 8                | 16 (1.6, 12)               |  |
| Cam chain guide lower roller pivot bolt | 1   | 6                | 10 (1.0, 7)                |  |
| Timing hole cap                         | 1   | 14               | 6.0 (0.6, 4.4)             |  |
| Crankshaft hole cap                     | 1   | 30               | 8.0 (0.8, 5.9)             |  |

## CYLINDER/PISTON

| ITEM                            | QTY | THREAD DIA. (mm) | TORQUE N·m (kgf·m, lbf·ft) | REMARKS       |
|---------------------------------|-----|------------------|----------------------------|---------------|
| Cam chain guide roller pin bolt | 1   | 8                | 10 (1.0, 7)                |               |
| Cylinder stud bolt              | 4   | 8                | -                          | See page 10-7 |

## CLUTCH/GEARSHIFT LINKAGE

| ITEM                                 | QTY | THREAD DIA. (mm) | TORQUE N·m (kgf·m, lbf·ft) | REMARKS  |
|--------------------------------------|-----|------------------|----------------------------|--|
| Clutch center lock nut               | 1   | 14               | 64 (6.5, 47)               | Apply engine oil to the threads and seating surface. |
| Clutch lifter plate bolt             | 3   | 6                | 12 (1.2, 9)                |  |
| Gearshift cam plate socket bolt      | 1   | 6                | 10 (1.0, 7)                | Apply locking agent to the threads.                  |
| Gearshift return spring pin          | 1   | 8                | 30 (3.1, 22)               |  |
| Oil filter rotor lock nut            | 1   | 14               | 64 (6.5, 47)               | Apply engine oil to the threads and seating surface. |
| Right crankcase cover protector bolt | 3   | 6                | 12 (1.2, 9)                |  |
| Shift drum stopper arm bolt          | 1   | 6                | 12 (1.2, 9)                | Apply locking agent to the threads.                  |

## GENERAL INFORMATION

### ALTERNATOR

| ITEM         | Q'TY | THREAD DIA. (mm) | TORQUE<br>N-m (kgf-m, lbf-ft) | REMARKS  |
|--------------|------|------------------|-------------------------------|--|
| Flywheel nut | 1    | 12               | 64 (6.5, 47)                  | Apply engine oil to the threads and seating surface. |

### FRONT WHEEL/SUSPENSION/STEERING

| ITEM                          | Q'TY | THREAD DIA. (mm) | TORQUE<br>N-m (kgf-m, lbf-ft) | REMARKS                             |
|-------------------------------|------|------------------|-------------------------------|-------------------------------------|
| Front axle nut                | 1    | 12               | 54 (5.5, 40)                  | U-nut                               |
| Front brake disc bolt         | 4    | 8                | 42 (4.3, 31)                  | ALOC bolt; replace with a new one.  |
| Fork bolt                     | 2    | 36               | 30 (3.1, 22)                  |                                     |
| Fork socket bolt              | 2    | 8                | 20 (2.0, 15)                  | Apply locking agent to the threads. |
| Steering stem nut             | 1    | 24               | 88 (9.0, 65)                  | See page 15-22                      |
| Steering stem adjusting nut   | 1    | 26               | 1.5 (0.2, 1.1)                | See page 15-22                      |
| Top bridge pinch bolt         | 2    | 8                | 27 (2.8, 20)                  |                                     |
| Bottom bridge pinch bolt      | 4    | 8                | 27 (2.8, 20)                  |                                     |
| Handlebar holder bolt         | 2    | 8                | 27 (2.8, 20)                  |                                     |
| Handlebar holder mounting nut | 2    | 8                | 27 (2.8, 20)                  |                                     |
| Handlebar weight screw        | 2    | 6                | 9.0 (0.9, 6.6)                | ALOC screw; replace with a new one. |
| Left handlebar switch screw   | 2    | 5                | 2.5 (0.3, 1.8)                |                                     |
| Right handlebar switch screw  | 2    | 5                | 2.5 (0.3, 1.8)                |                                     |
| Clutch lever pivot bolt       | 1    | 6                | 1.0 (0.1, 0.7)                |                                     |
| Clutch lever pivot nut        | 1    | 6                | 5.9 (0.6, 4.4)                |                                     |

### REAR WHEEL/SUSPENSION

| ITEM                              | Q'TY | THREAD DIA. (mm) | TORQUE<br>N-m (kgf-m, lbf-ft) | REMARKS                            |
|-----------------------------------|------|------------------|-------------------------------|------------------------------------|
| Rear axle nut                     | 1    | 12               | 59 (6.0, 44)                  | U-nut                              |
| Driven sprocket nut               | 4    | 8                | 32 (3.3, 24)                  | U-nut                              |
| Rear brake disc bolt              | 4    | 8                | 42 (4.3, 31)                  | ALOC bolt; replace with a new one. |
| Shock absorber upper mounting nut | 1    | 10               | 44 (4.5, 32)                  | U-nut                              |
| Shock absorber lower mounting nut | 1    | 10               | 44 (4.5, 32)                  | U-nut                              |
| Swingarm pivot nut                | 1    | 12               | 54 (5.5, 40)                  | U-nut                              |
| Drive chain slider screw          | 2    | 5                | 6.0 (0.6, 4.4)                |                                    |
| Driven sprocket stud bolt         | 4    | 8                | -                             | See page 16-7                      |

### HYDRAULIC BRAKE

| ITEM                                       | Q'TY | THREAD DIA. (mm) | TORQUE<br>N-m (kgf-m, lbf-ft) | REMARKS                             |
|--|------|------------------|-------------------------------|-------------------------------------|
| Brake hose oil bolt                        | 4    | 10               | 34 (3.5, 25)                  |                                     |
| Master cylinder reservoir cover screw      | 4    | 4                | 1.5 (0.2, 1.1)                |                                     |
| Front brake light switch screw             | 1    | 4                | 1.2 (0.1, 0.2)                |                                     |
| Brake lever pivot bolt                     | 1    | 6                | 1.0 (0.1, 0.7)                |                                     |
| Brake lever pivot nut                      | 1    | 6                | 5.9 (0.6, 4.4)                |                                     |
| Front brake caliper mounting bolt          | 2    | 8                | 30 (3.1, 22)                  | ALOC bolt; replace with a new one.  |
| Front brake caliper pin bolt               | 1    | 8                | 17 (1.7, 13)                  |                                     |
| Brake pad hanger pin                       | 2    | 10               | 17 (1.7, 13)                  |                                     |
| Brake caliper bleed valve                  | 2    | 8                | 5.4 (0.6, 4.0)                |                                     |
| Rear master cylinder push rod lock nut     | 1    | 8                | 17 (1.7, 13)                  |                                     |
| Rear master cylinder hose joint screw      | 1    | 4                | 1.5 (0.2, 1.1)                | Apply locking agent to the threads. |
| Step holder mounting bolt                  | 2    | 8                | 31 (3.2, 23)                  |                                     |
| Front master cylinder holder bolt          | 2    | 6                | 10 (1.0, 7)                   |                                     |
| Rear master cylinder oil cap mounting bolt | 1    | 6                | 10 (1.0, 7)                   |                                     |
| Rear master cylinder mounting bolt         | 2    | 6                | 12 (1.2, 9)                   | ALOC bolt; replace with a new one.  |

## LIGHTS/METERS/SWITCHES

| ITEM                         | QTY | THREAD<br>DIA. (mm) | TORQUE<br>N·m (kgf·m, lbf·ft) | REMARKS |
|------------------------------|-----|---------------------|-------------------------------|---------|
| Tail light unit mounting nut | 2   | 6                   | 1.0 (1.0, 7)                  |         |
| Combination meter screw      | 8   | 3                   | 1.0 (0.1, 0.7)                |         |

## LUBRICATION &amp; SEAL POINTS

## ENGINE

| MATERIAL   | LOCATION  | REMARKS                     |
|--|---|-----------------------------|
| Engine oil   | Cylinder bore                                     |                             |
|  | Piston outer sliding area and piston ring grooves |                             |
|  | Piston pin hole inner surface                     |                             |
|  | Piston pin outer surface                          |                             |
|  | Piston ring whole surface                         |                             |
|  | Connecting rod small end inner surface            |                             |
|  | Connecting rod big end                            | 1 – 2 cm <sup>3</sup>       |
|  | IN/EX valve stem outer surface and stem end       |                             |
|  | Camshaft whole surface                            |                             |
|  | Cam chain whole surface                           |                             |
|  | Rocker arm shaft hole inner surface               |                             |
|  | Rocker arm shaft whole surface                    |                             |
|  | Rocker arm roller rolling area                    |                             |
|  | Oil pump inner and outer rotor sliding area       |                             |
|  | Clutch outer guide outer surface                  |                             |
|  | Clutch disc whole surface                         |                             |
|  | Gearshift spindle journal                         |                             |
|  | Shift fork shaft whole surface                    |                             |
|  | Shift drum whole surface                          |                             |
|  | Cam chain tensioner push rod inside               | 4.0 cm <sup>3</sup> minimum |
|  | Starter reduction gear both journal area          |                             |
|  | Starter reduction gear shaft whole surface        |                             |
|  | Starter clutch rolling surface                    |                             |
| Each bearing rolling surface   |   |                             |
| Each O-ring  |   |                             |
| Locking agent  | Mainshaft bearing set plate bolt threads          |                             |
|  | Shift drum stopper plate bolt threads             |                             |
|  | Shift drum stopper arm pivot bolt threads         |                             |
|  | Oil filter cover bolt threads                     |                             |
|  | Starter clutch outer socket bolt threads          |                             |
| Molybdenum disulfide oil (a mixture of 1/2 engine oil and 1/2 molybdenum disulfide grease) | Decompressor cam and arm sliding area             |                             |
|  | Each transmission rotating gear inner surface     |                             |
|  | C1 gear bushing whole surface                     |                             |
|  | M4, C3 gear shift fork groove                     |                             |
|  | Clutch lever shaft outer surface                  |                             |
| Sealant (Three bond 1215 / 1207B or equivalent)  | Clutch lifter rod surface                         |                             |
|  | Left crankcase mating surface                     | See page 13-6               |
| Multi-purpose grease   | Alternator wire grommet seating surface           |                             |
|  | Gearshift spindle oil seal lip                    |                             |
| Degreasing   | Countershaft oil seal lip                         |                             |
|  | Flywheel and left crankshaft contact areas        |                             |

## GENERAL INFORMATION

### FRAME

| MATERIAL  | LOCATION  | REMARKS            |
|---|---|--------------------|
| Urea based multi-purpose grease with extreme pressure NLGI#2 (example: ALVANIA EP2 manufactured by Shell or EXCELITE EP2 manufactured by Kyodo Yushi CO., LTD. or equivalent) | Steering head bearing rolling surface   | 3.0 g minimum each |
|   | Steering head bearing dust seal lips  | 3.0 g minimum      |
| Multi-purpose grease  | Axle rolling surface  |                    |
|   | Swingarm pivot bolt sliding surface   |                    |
|   | Sidestand pivot sliding area  |                    |
|   | Gearshift pedal pivot sliding area  |                    |
|   | Gearshift tie rod sliding area  |                    |
|   | Seat lock cam sliding area  | 1.5 g minimum      |
|   | Throttle grip pipe flange sliding area  |                    |
|   | Clutch lever pivot bolt sliding area  |                    |
|   | Brake pedal pivot sliding area  |                    |
|   | Wheel dust seal lip   |                    |
|   | Main step pivot pin sliding area  |                    |
|   | Pillion step pivot pin sliding area   |                    |
|   | Gearshift pedal pivot bolts sliding area  |                    |
|   | Gearshift tie-rod ball joint  |                    |
|   | Rear wheel dust seal lip  |                    |
| Each dust seal lips   |   |                    |
| Silicone grease   | Each O-ring   |                    |
|   | Brake caliper pin bolt sliding surface  | 0.4 g minimum      |
|   | Brake caliper dust seal   |                    |
|   | Brake pad hanger pin O-ring   |                    |
|   | Brake lever pivot bolt sliding surface  | 0.1 g              |
|   | Brake lever contacting area (master piston)                                     | 0.1 g              |
| Honda DOT 4 brake fluid   | Rear master cylinder push rod contacting area (master cylinder piston and boot) | 0.1 g each         |
|   | Brake master piston sliding area  |                    |
| Locking agent   | Brake caliper piston sliding area and piston seal                               |                    |
|   | Fork socket bolt threads  |                    |
|   | Driven sprocket stud bolt threads   |                    |
| Fork fluid  | Rear master cylinder hose joint screw threads                                   |                    |
|   | Fork bolt O-ring  |                    |
|   | Fork oil seal lips  |                    |
| Honda Bond A or Honda Hand Grip Cement (U.S.A. only)  | Left handlebar grip rubber inside   |                    |
|   | Air cleaner connecting hose mating surface                                      |                    |

## CABLE &amp; HARNESS ROUTING

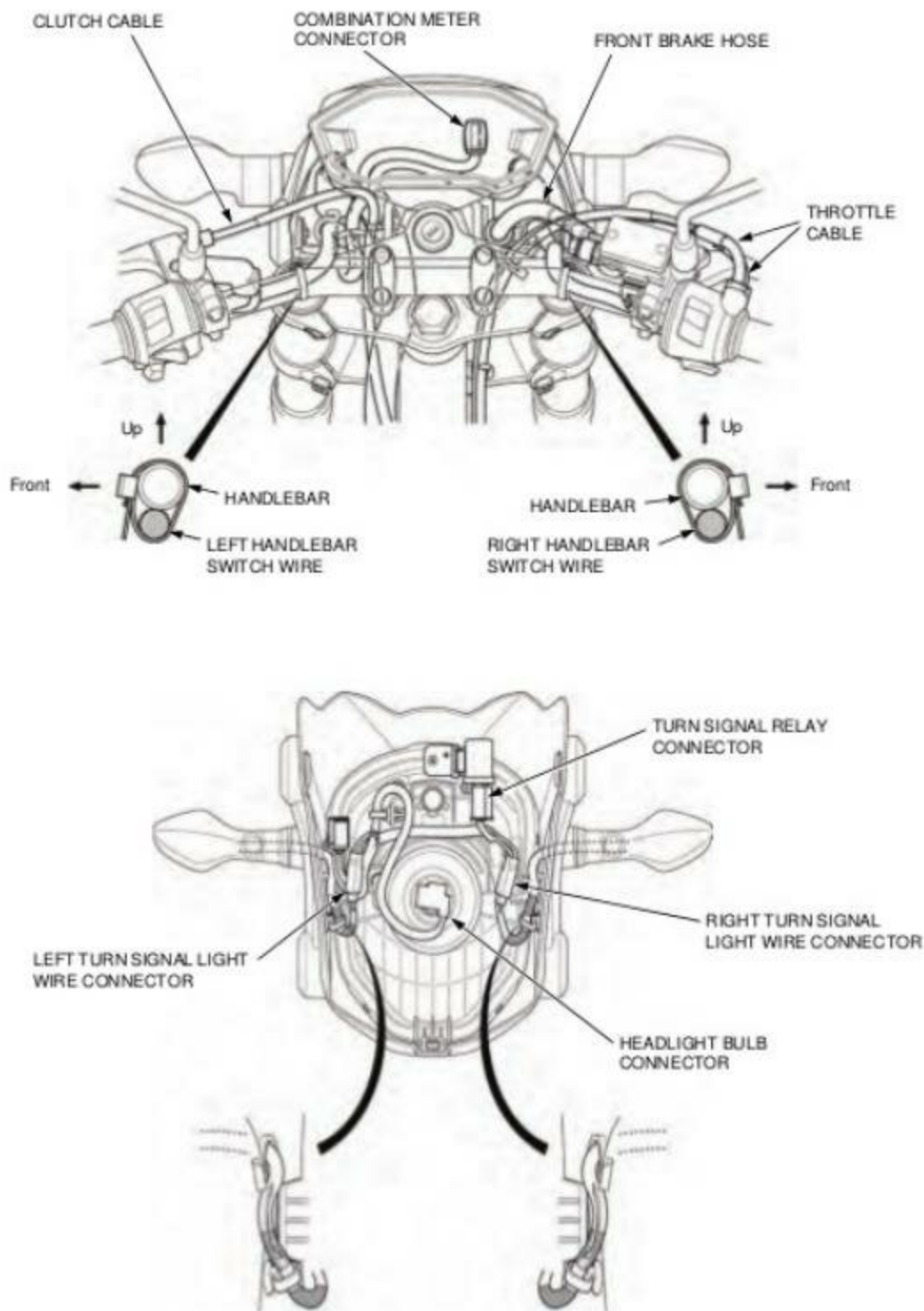

## GENERAL INFORMATION

---

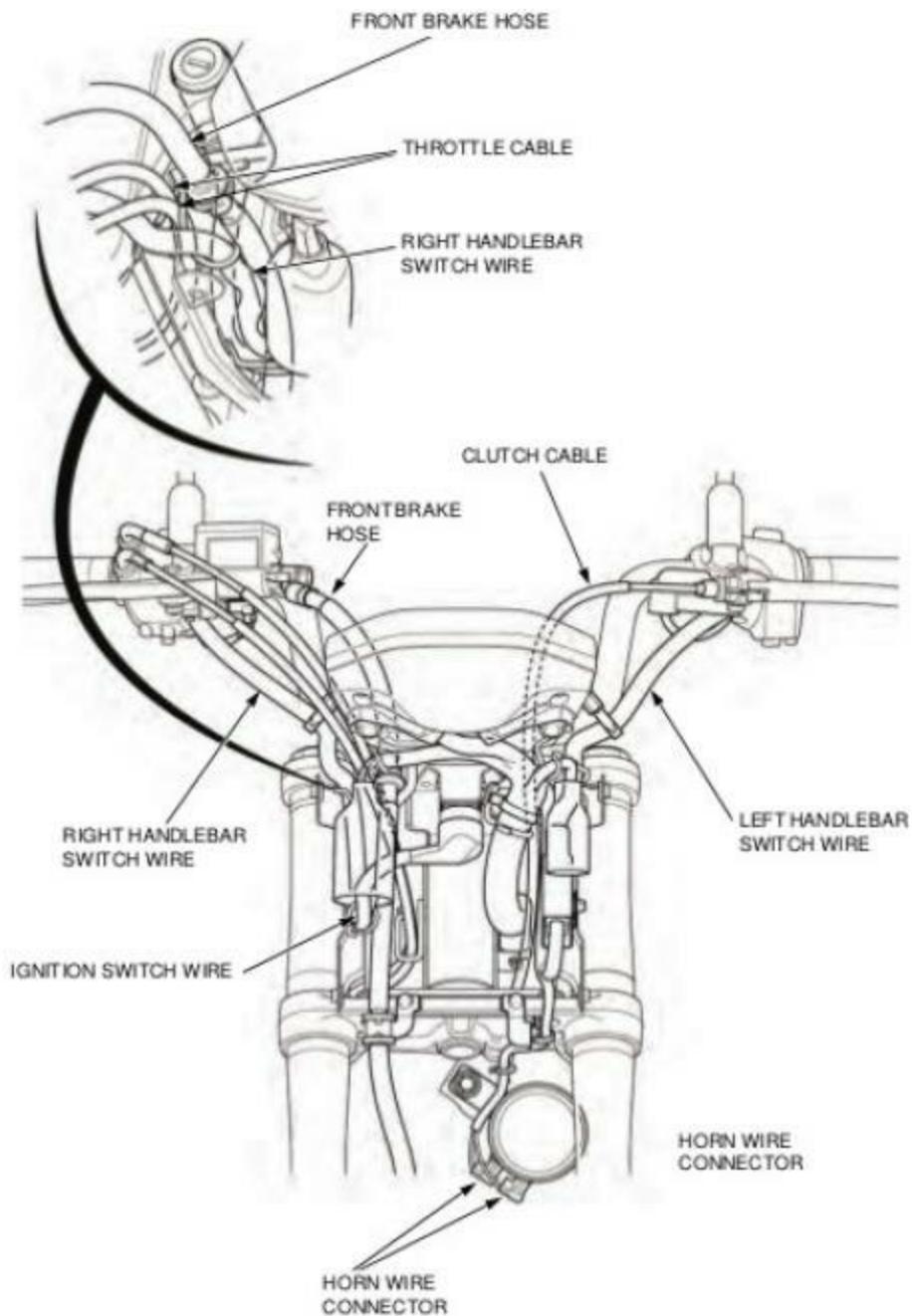

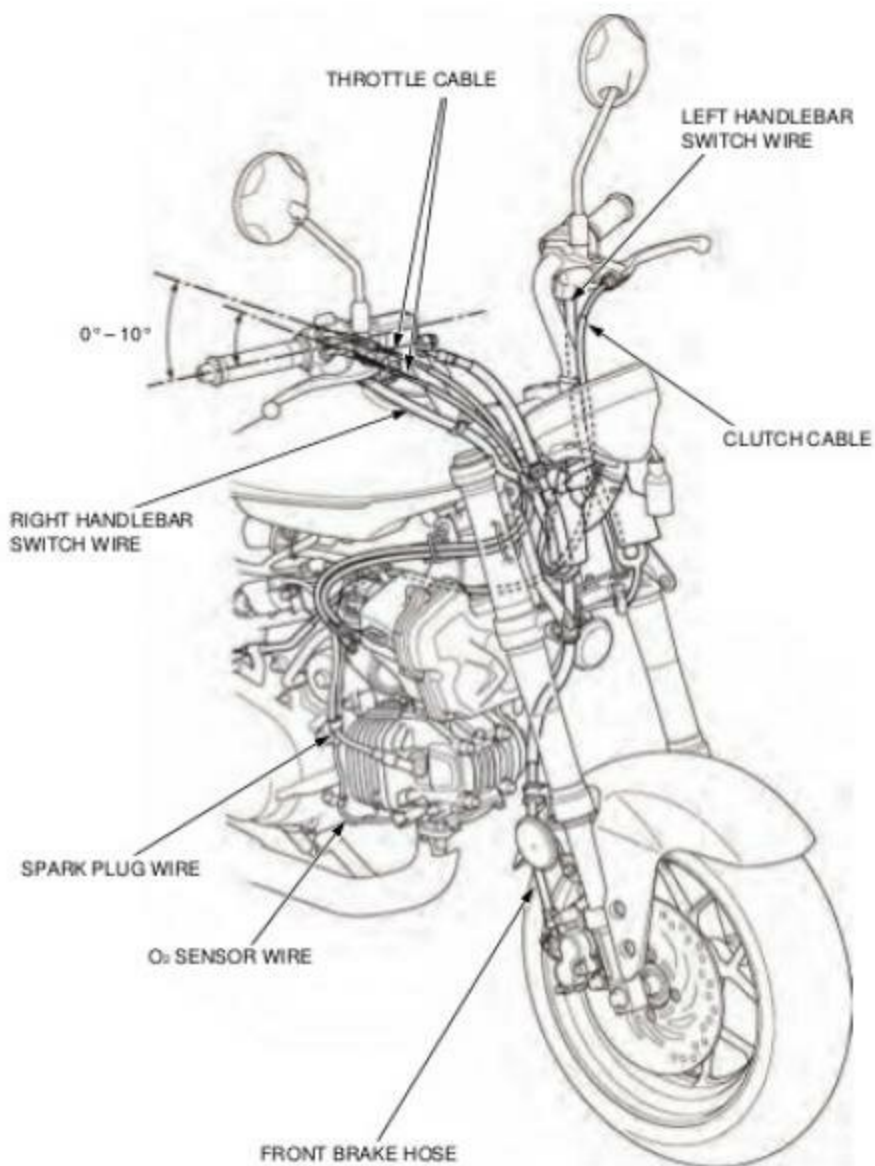

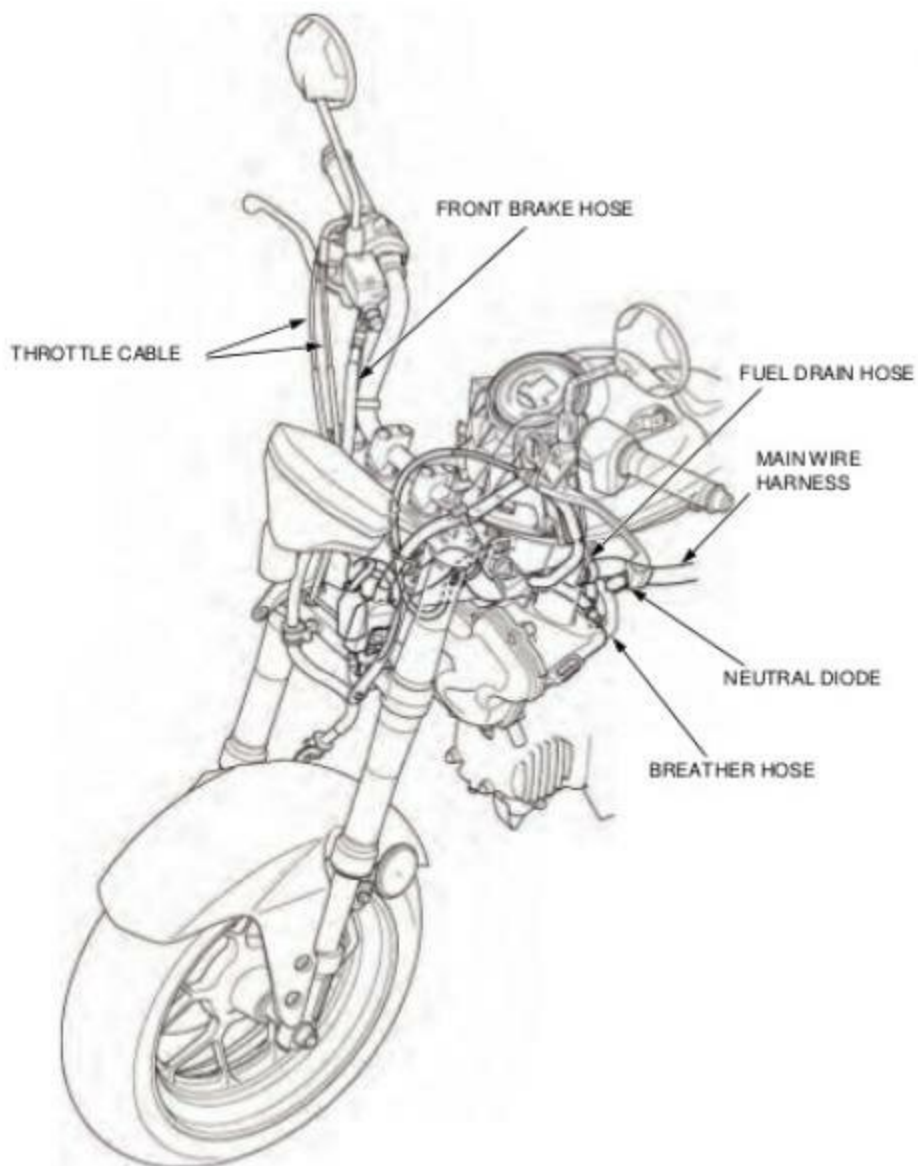

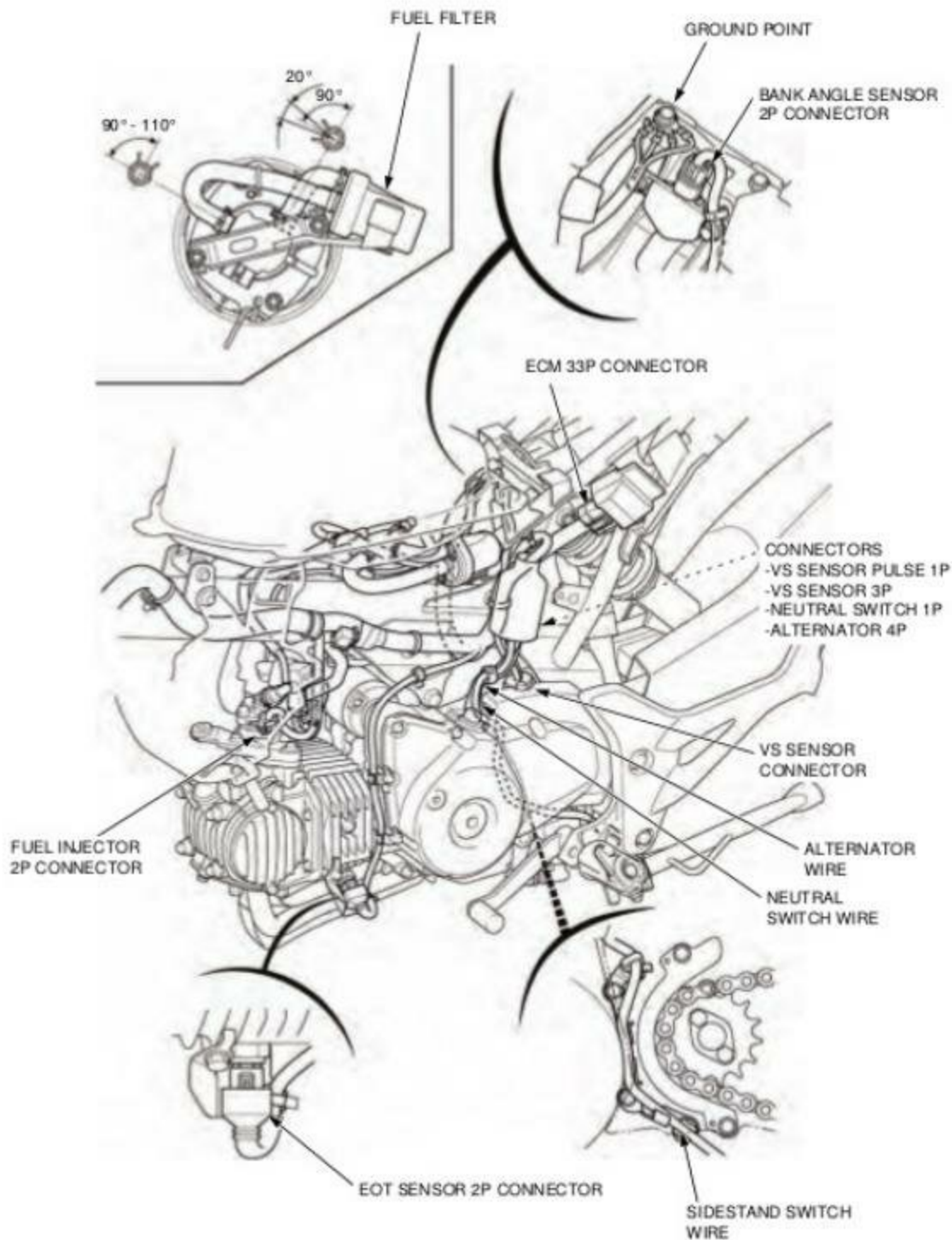

## GENERAL INFORMATION

---

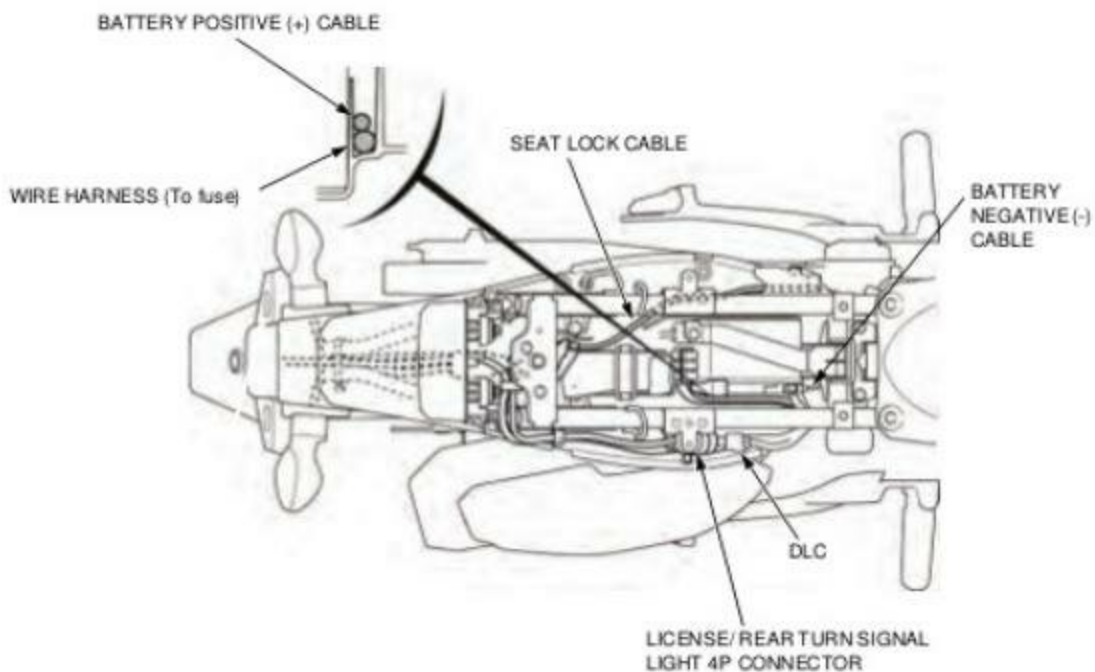
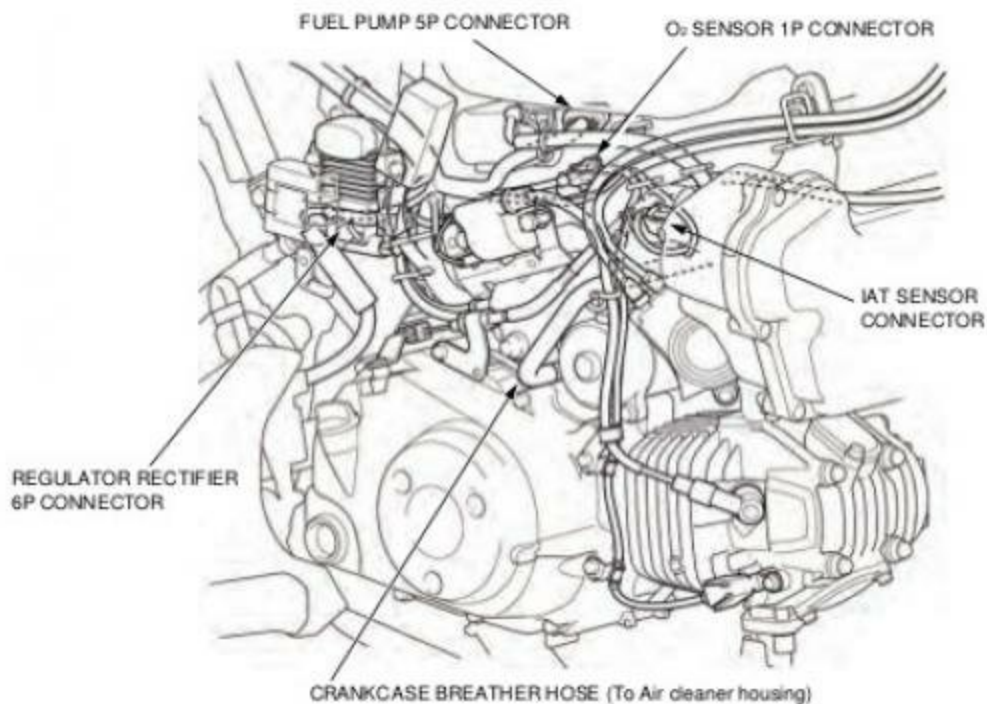

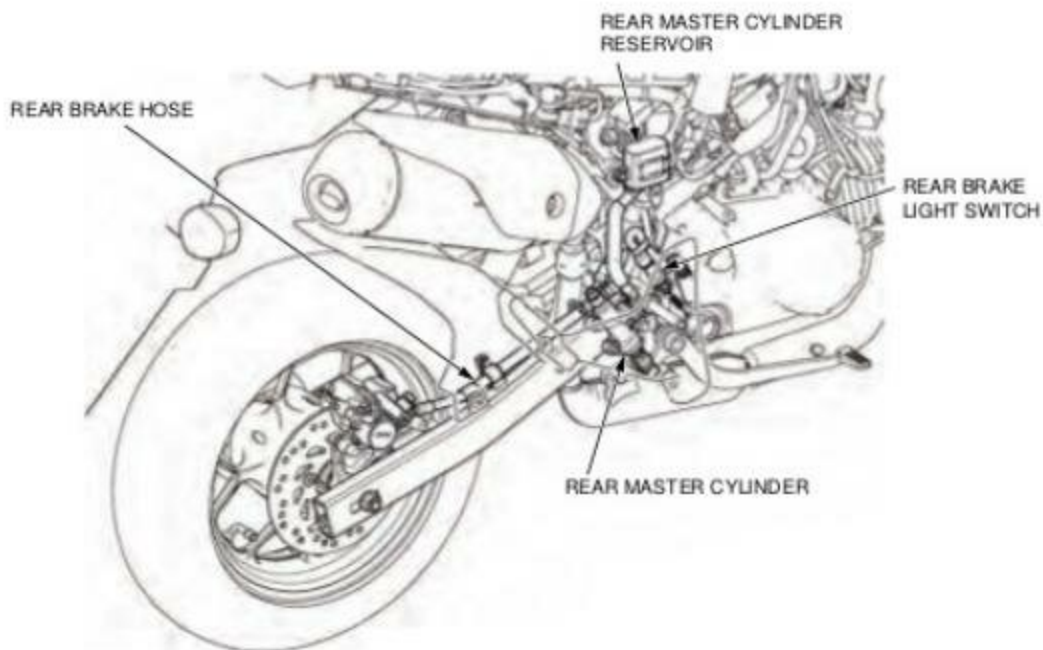
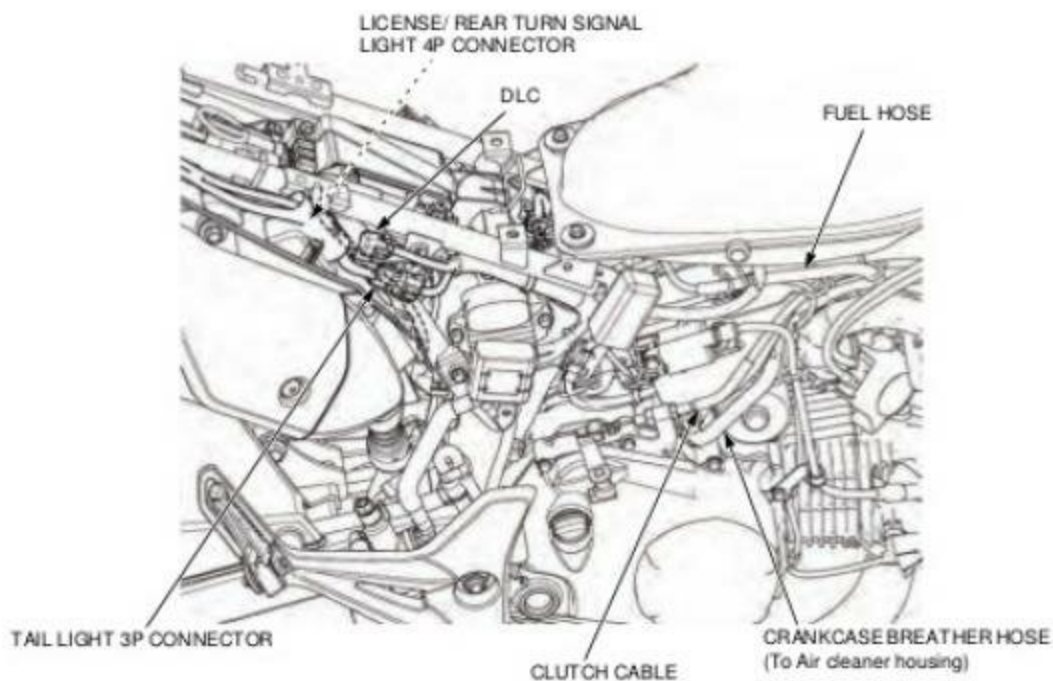

## GENERAL INFORMATION

---

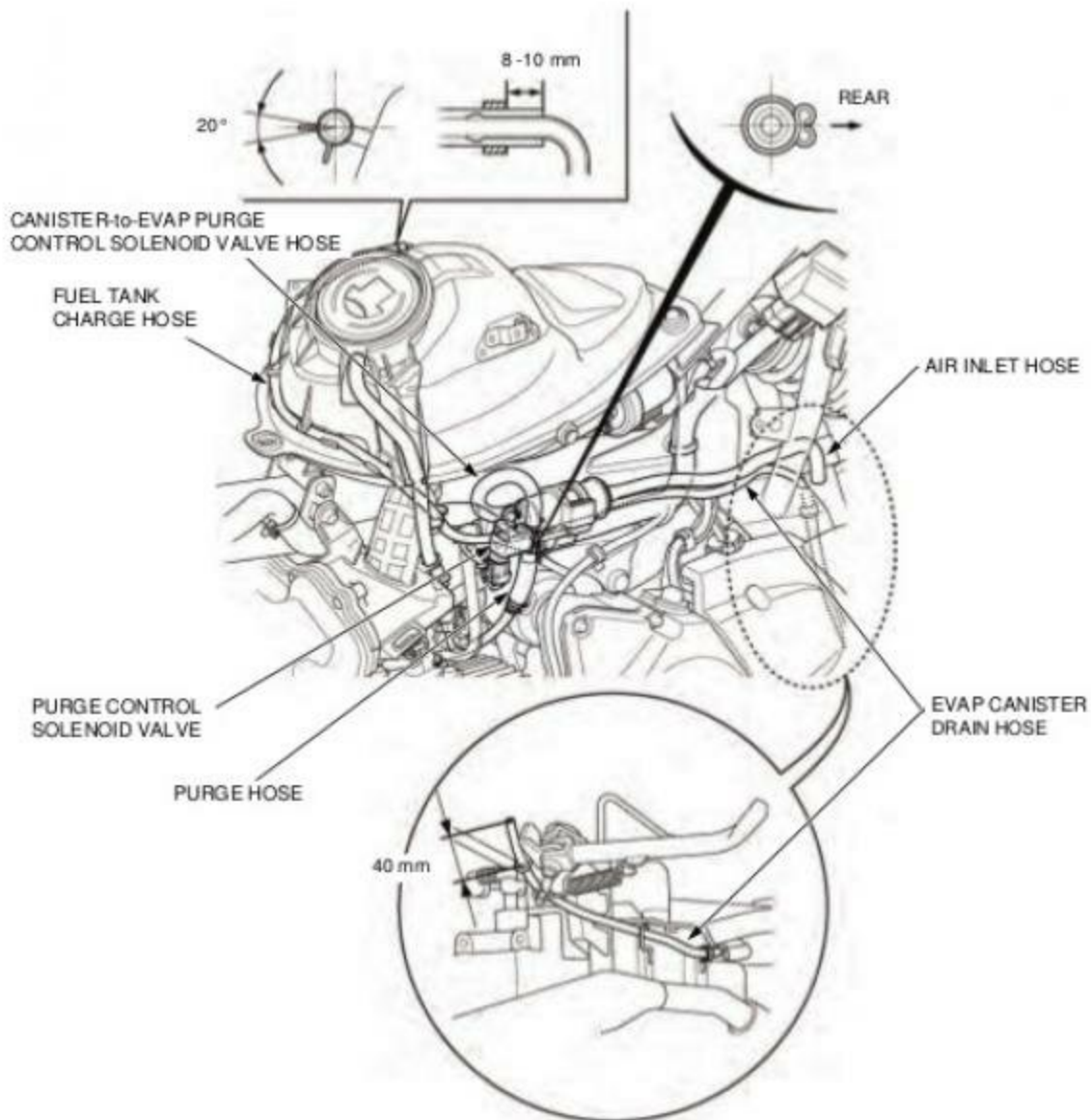

**TECHNICAL FEATURES****PGM-FI SYSTEM WITHOUT MAP SENSOR AND IACV****SYSTEM COMPONENTS**

The PGM-FI system of this model consists of the following components:

- Injector [1]
- Fuel pump unit [2]
- ECM [3]
- CKP sensor [4]
- TP sensor [5]
- EOT sensor [6]
- IAT sensor [7]
- O<sub>2</sub> sensor [8]
- Throttle body [9]
- Idle air screw [10]

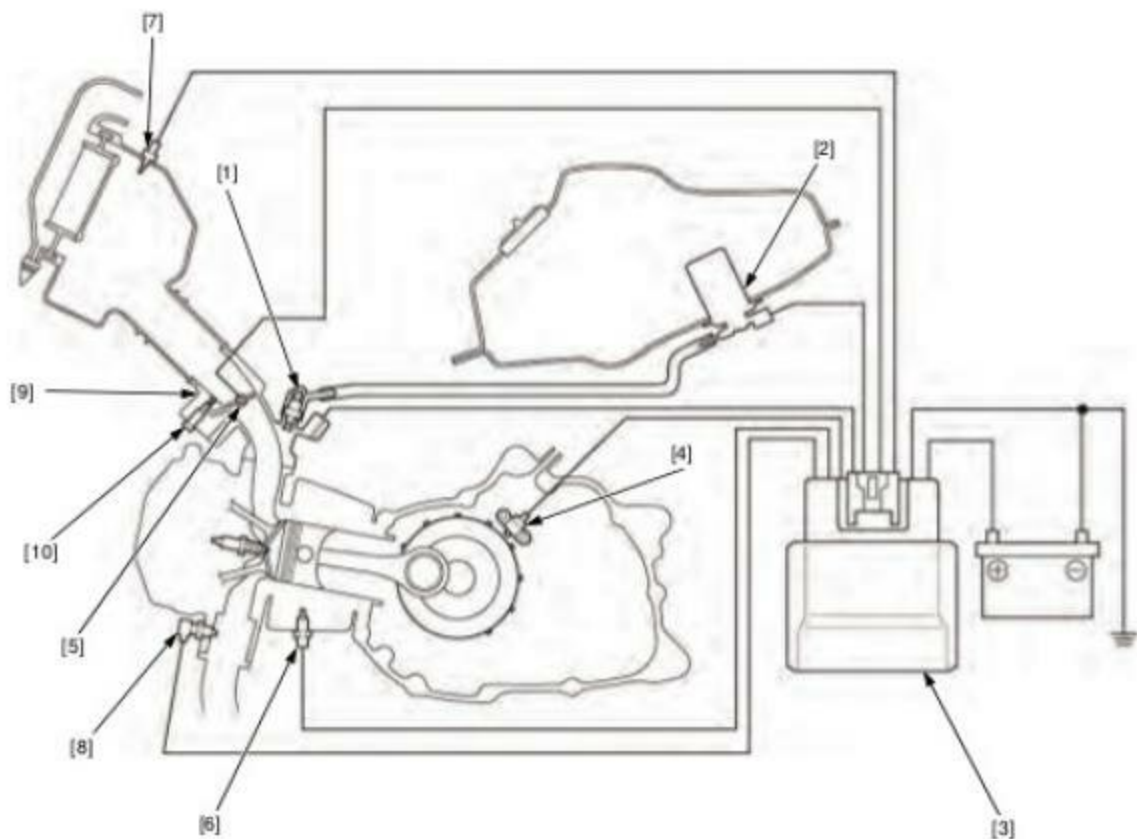

For PGM-FI system diagram (page 4-4).

## GENERAL INFORMATION

### SYSTEM OUTLINE

This model's PGM-FI system eliminates the need of a MAP (Manifold Absolute Pressure) sensor and IACV (Idle Air Control Valve).

The system uses feedback from the O<sub>2</sub> (Oxygen) and CKP (Crankshaft Position) sensors to compensate for the functions usually completed by the MAP sensor.

The basic fuel discharge duration maps, which are programmed into the ECM, are constantly revised based on the O<sub>2</sub> sensor feedback.

As crankshaft speed slows slightly during the compression stroke, the CKP sensor signal allows the ECM to determine the exact timing of the combustion process. This information would normally be provided by the MAP sensor.

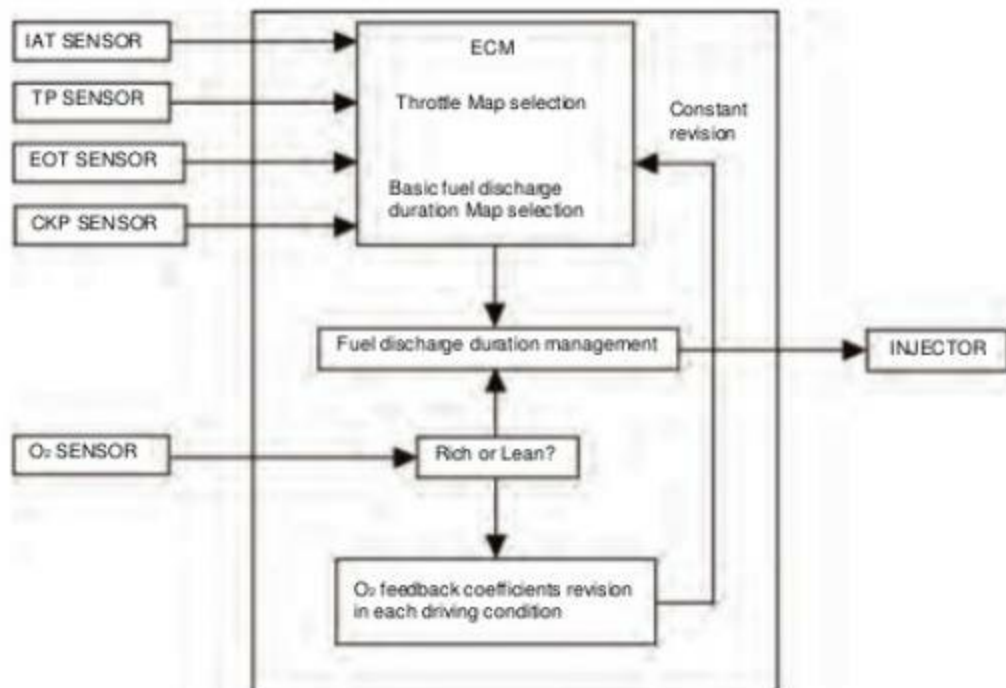

### IDLE AIR SCREW

The idle air screw [1] is located on the throttle body [2]. The idle air passage [3] provides required air flow during idle speed operation.

The idle air passage is designed in a crank shape, which is not easily affected by deposits generated by reverse flow from the combustion chamber. The volume of air flow can be adjusted by turning the idle air screw to increase/decrease the gap between the screw and idle air passage wall in the throttle body.

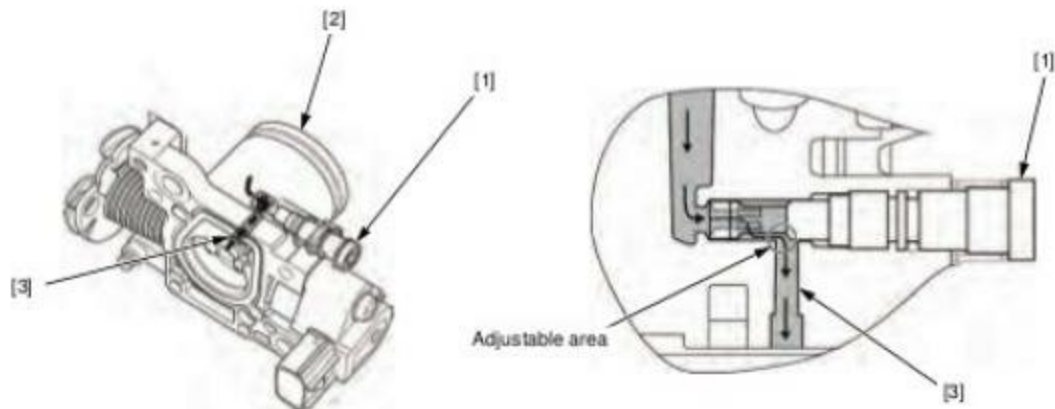

## EMISSION CONTROL SYSTEMS

### SOURCE OF EMISSIONS

The combustion process produces carbon monoxide (CO), oxides of nitrogen (NOx) and hydrocarbons (HC). Control of carbon monoxide, oxides of nitrogen and hydrocarbons is very important because, under certain conditions, they react to form photochemical smog when subject to sunlight. Carbon monoxide does not react in the same way, but it is toxic.

### CRANKCASE EMISSION CONTROL SYSTEM

The engine is equipped with a closed crankcase system to prevent discharging crankcase emissions into the atmosphere. Blow-by gas is returned to the combustion chamber through the crankcase breather hose [1], air cleaner [2] and throttle body [3].

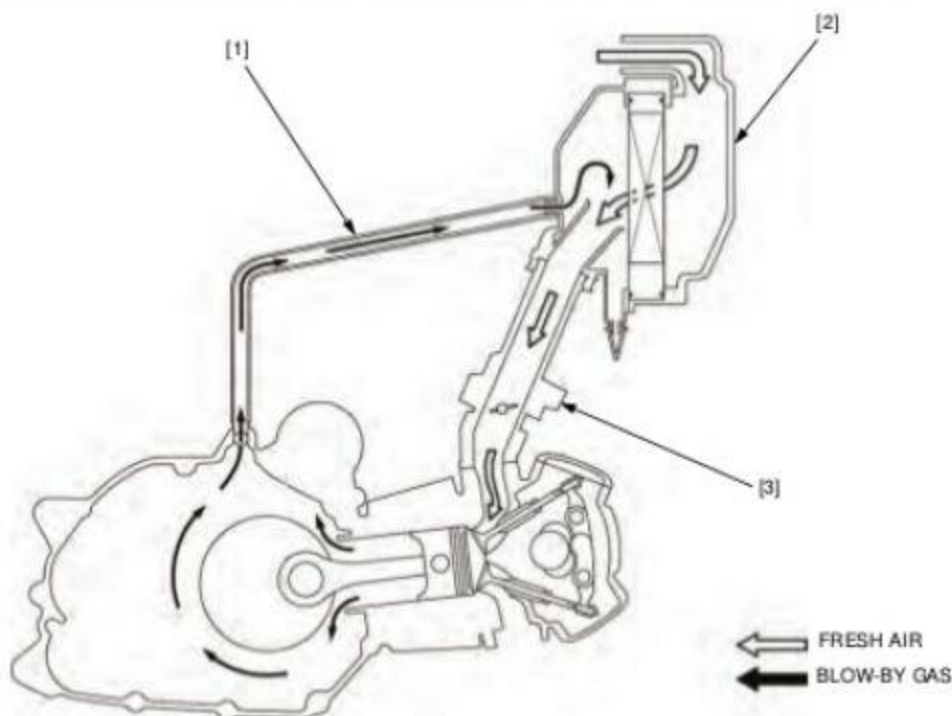

### THREE-WAY CATALYTIC CONVERTER

This motorcycle is equipped with a three-way catalytic converter.

The three-way catalytic converter is in the exhaust system. Through chemical reactions, they convert HC, CO and NOx in the engine's exhaust to carbon dioxide (CO<sub>2</sub>), nitrogen (N<sub>2</sub>) and water vapor.

No adjustment to these systems should be made although periodic inspection of the components is recommended.

### NOISE EMISSION CONTROL SYSTEM

**TAMPERING WITH THE NOISE CONTROL SYSTEM IS PROHIBITED:** Local law may prohibit the following acts or the causing thereof: (1) The removal or rendering inoperative by any person, other than for purposes of maintenance, repair or replacement, of any device or element of design incorporated into any vehicle for the purpose of noise control prior to its sale or delivery to the ultimate customer or while it is in use; (2) the use of the vehicle after such device or element of design has been removed or rendered inoperative by any person.

AMONG THOSE ACTS PRESUMED TO CONSTITUTE TAMPERING ARE THE ACTS LISTED BELOW:

1. Removal of, or puncturing of the muffler, baffles, header pipes or any other component which conducts exhaust gases.
2. Removal of, or puncturing of any part of the intake system.
3. Lack of proper maintenance.
4. Removing or disabling any emissions compliance component, or replacing any compliance component with a non-compliant component.

---

**MEMO**

---

## 10. CYLINDER/PISTON

---

|                           |      |                       |      |
|---------------------------|------|-----------------------|------|
| SERVICE INFORMATION ..... | 10-2 | CYLINDER/PISTON ..... | 10-3 |
| TROUBLESHOOTING .....     | 10-2 |                       |      |

## CYLINDER/PISTON

# SERVICE INFORMATION

## GENERAL

- This section covers service of the cylinder and piston. These services can be performed with the engine installed in the frame.
- Take care not to damage the cylinder wall and piston.
- Be careful not to damage the mating surfaces when removing the cylinder. Do not tap the cylinder too hard during removal.
- When disassembling, mark and store the disassembled parts to ensure that they are reinstalled in their original locations.
- Clean all disassembled parts with cleaning solvent and dry them by blowing them off with compressed air before inspection.

## SPECIFICATIONS

Unit: mm (in)

| ITEM                                   |  | STANDARD                          | SERVICE LIMIT                   |                |
|--|--|-----------------------------------|---------------------------------|----------------|
| Cylinder                               | I.D.   | 52.405 - 52.415 (2.0632 - 2.0636) | 52.445 (2.0648)                 |                |
|  | Out-of-round                                   | -                                 | 0.10 (0.004)                    |                |
|  | Taper  | -                                 | 0.10 (0.004)                    |                |
|  | Warpage  | -                                 | 0.05 (0.002)                    |                |
| Piston, piston rings, piston pin       | Piston O.D.                                    | 52.380 - 52.395 (2.0622 - 2.0628) | 52.310 (2.0594)                 |                |
|  | Piston O.D. measurement point                  | 10 mm from bottom of skirt        | -                               |                |
|  | Piston pin bore I.D.                           | 13.002 - 13.008 (0.5119 - 0.5121) | 13.03 (0.5130)                  |                |
|  | Piston pin O.D.                                | 12.994 - 13.000 (0.5116 - 0.5118) | 12.98 (0.5110)                  |                |
|  | Piston-to-piston pin clearance                 | 0.002 - 0.014 (0.0001 - 0.0005)   | 0.05 (0.002)                    |                |
|  | Piston ring-to-ring groove clearance (RIKEN)   | Top                               | 0.030 - 0.065 (0.0012 - 0.0026) | 0.100 (0.0039) |
|  |  | Second                            | 0.015 - 0.050 (0.0006 - 0.0020) | 0.090 (0.0035) |
|  | Piston ring-to-ring groove clearance (TEIKOKU) | Top                               | 0.015 - 0.050 (0.0006 - 0.0020) | 0.090 (0.0035) |
|  |  | Second                            | 0.015 - 0.050 (0.0006 - 0.0020) | 0.090 (0.0035) |
|  | Piston ring endgap (RIKEN)                     | Top                               | 0.10 - 0.25 (0.004 - 0.010)     | 0.50 (0.020)   |
|  |  | Second                            | 0.10 - 0.30 (0.004 - 0.012)     | 0.60 (0.024)   |
| Oil (side rail)                        |  | 0.20 - 0.70 (0.008 - 0.028)       | 1.10 (0.043)                    |                |
| Piston ring endgap (TEIKOKU)           | Top  | 0.10 - 0.25 (0.004 - 0.010)       | 0.50 (0.020)                    |                |
|  | Second   | 0.35 - 0.50 (0.014 - 0.020)       | 0.75 (0.030)                    |                |
|  | Oil (side rail)                                | 0.10 - 0.35 (0.004 - 0.014)       | 1.10 (0.043)                    |                |
| Cylinder-to-piston clearance           | 0.010 - 0.035 (0.0004 - 0.0014)                | 0.10 (0.004)                      |                                 |                |
| Connecting rod small end I.D.          | 13.010 - 13.028 (0.5122 - 0.5129)              | 13.05 (0.514)                     |                                 |                |
| Connecting rod-to-piston pin clearance | 0.010 - 0.034 (0.0004 - 0.0013)                | 0.07 (0.003)                      |                                 |                |

## TORQUE VALUES

### CYLINDER/PISTON

| ITEM                            | Q'TY | THREAD DIA. (mm) | TORQUE N-m (kgf-m, lbf-ft) | REMARKS       |
|---------------------------------|------|------------------|----------------------------|---------------|
| Cam chain guide roller pin bolt | 1    | 8                | 10 (1.0, 7)                |               |
| Cylinder stud bolt              | 4    | 8                | -                          | See page 10-7 |

## TROUBLESHOOTING

### Compression too low, hard starting or poor performance at low speed

- Leaking cylinder head gasket
- Worn, stuck or broken piston ring
- Worn or damaged cylinder and piston
- Bent connecting rod

### Compression too high, overheating or knocking

- Excessive carbon built-up on piston head or combustion chamber

### Excessive smoke

- Worn cylinder, piston or piston rings
- Improper installation of piston rings
- Scored or scratched piston or cylinder wall
- Cylinder head/valve problem (page 10-7)

### Abnormal noise

- Worn piston pin or piston pin hole
- Worn cylinder, piston or piston rings
- Worn connecting rod small end

## CYLINDER/PISTON

|                     |   |
|---------------------|---|
| *Markings facing up | TOP RING MARKINGS:<br>RIKEN: R<br>TEIKOKU: N/T, T     |
|                     | SECOND RING MARKINGS:<br>RIKEN: RS<br>TEIKOKU: T2, A2 |

|   |   |
|---|---|
|  | Apply engine oil:                                 |
| -   | Cylinder bore                                     |
| -   | Piston outer sliding area and piston ring grooves |
| -   | Piston pin hole inner surface                     |
| -   | Piston pin outer surface                          |
| -   | Piston ring whole surface                         |
| -   | Connecting rod small end inner surface            |
| -   | Connecting rod big end                            |

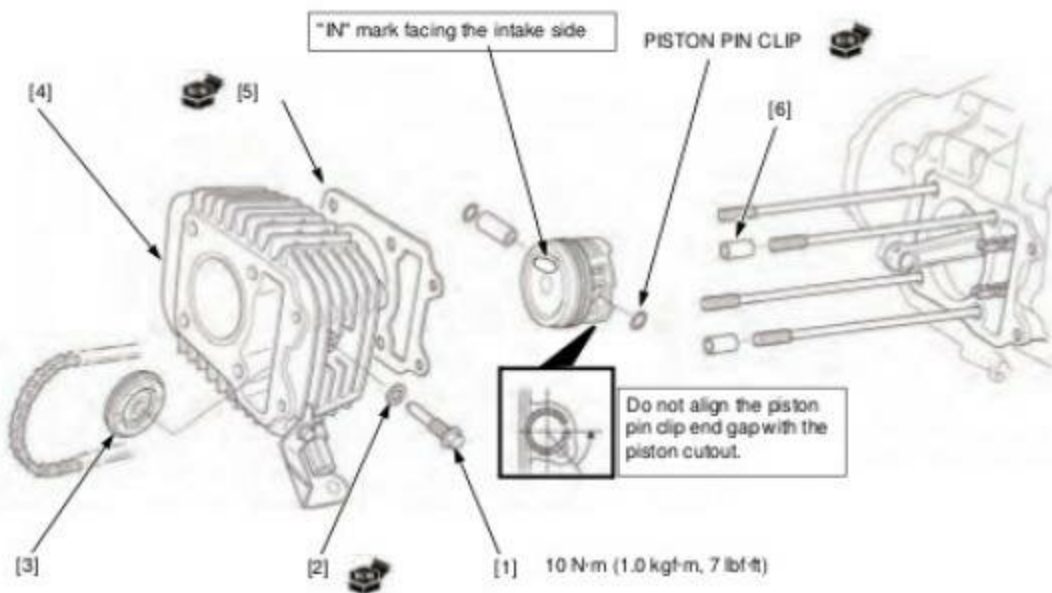
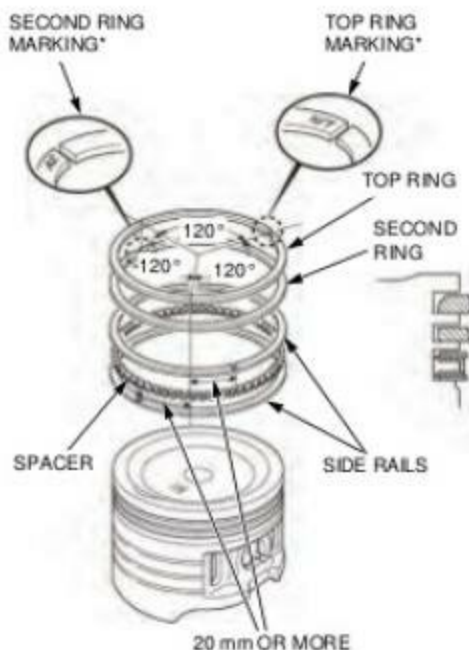

## CYLINDER/PISTON

### REMOVAL

#### NOTE:

- Cylinder and piston can be serviced with the engine installed on the frame.
- Perform the ECM initializing procedure (page 4-24) if the cylinder is replaced or is overhauled.

Remove the cylinder head (page 9-9).

Disconnect the EOT sensor 2P connector (page 4-27).

*Be careful not to drop the guide roller into the crankcase.*

Remove the cam chain guide roller pin bolt [1], sealing washer [2] and guide roller [3]

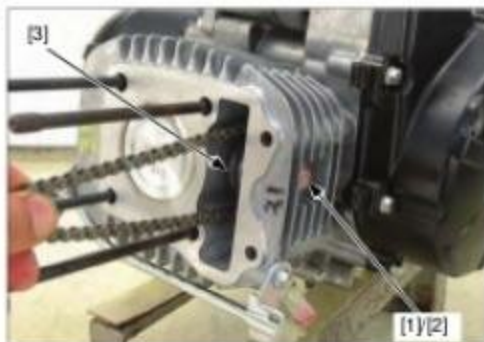

Remove the cylinder.

Remove the gasket [1] and dowel pins [2].

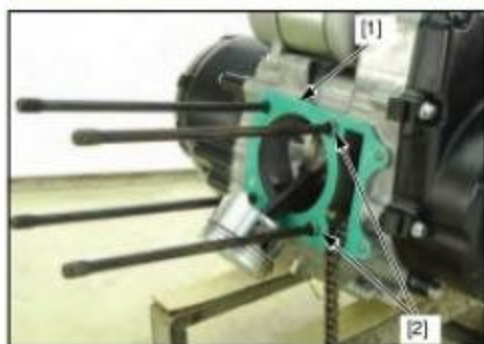

*Place a clean shop towel over the crankcase to prevent the clip from falling into the crankcase.*

Remove the piston pin clip [1] with pliers.

Push the piston pin [2] out of the piston [3] and connecting rod, and remove the piston.



**INSTALLATION**

Install the dowel pins [1] and a new gasket [2].

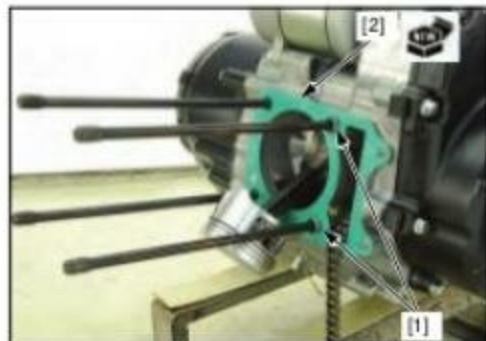

Apply oil to the cylinder bore, piston sliding area, piston ring grooves and piston rings whole surface.

Route the cam chain [1] through the cylinder [2].

*Be careful not to damage the piston rings and cylinder bore.*

Install the cylinder over the piston while compressing the piston rings with your fingers.

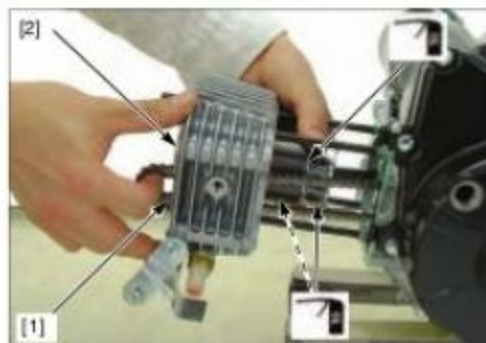

*Be careful not to drop the guide roller into the crankcase.*

Install the cam chain guide roller [1], new sealing washer [2] and cam chain guide roller pin bolt [3]. Tighten the roller pin bolt to the specified torque.

**TORQUE: 10 N·m (1.0 kgf·m, 7 lbf·ft)**

Connect the EOT sensor 2P connector (page 4-27).

Install the cylinder head (page 9-10).

- Perform the ECM initializing procedure (page 4-24) if the cylinder is replaced or is overhauled.

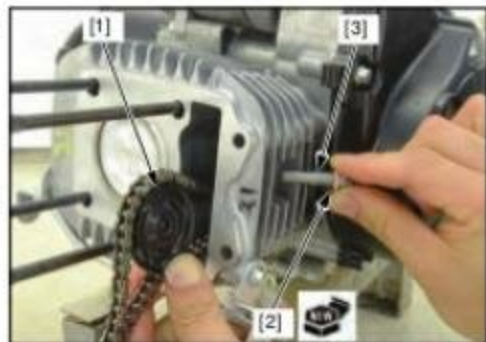

## CYLINDER/PISTON

Clean the piston heads, ring grooves and skirts.  
Carefully install the piston rings onto the piston with their markings facing up.

### TOP RING MARKINGS:

RIKEN: R

TEIKOKU: N,T

### SECOND RING MARKINGS:

RIKEN: RS

TEIKOKU: A2, T2

### NOTE:

- Be careful not to damage the piston and piston rings during installation.
- Do not confuse the top and second rings.
- When installing the oil ring, install the spacer first and then the side rails.

*Do not align the gaps of the oil ring side rails.*

Stagger the piston ring end gaps 120 degrees apart from each other as shown.

Stagger the side rails gaps as shown.

After installation, the piston rings should be free to rotate in the groove.

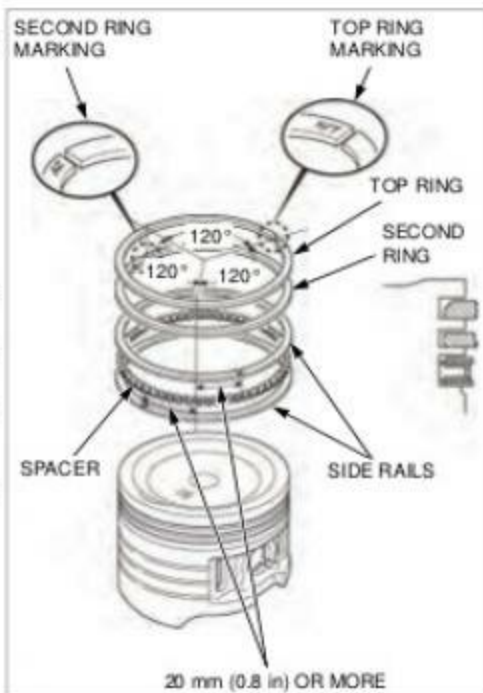

*Be careful not to damage the gasket mating surfaces.*

Place a clean shop towel over the crankcase to prevent the dirt, dust or piston pin clips from entering the crankcase.

Clean the gasket mating surfaces of the crankcase and cylinder thoroughly.

Apply oil to the connecting rod small end inner surface.



Apply oil to the piston [1] pin hole inner surface and piston pin [2] outer surface.

Install the piston with the "IN" mark [3] facing the intake side.

Install the piston pin.

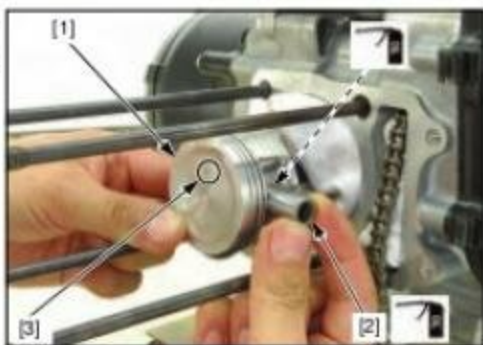

Install the new piston pin clip [1].

**NOTE:**

- Make sure the piston pin clips are seated securely.
- Do not align the piston pin clip end gap with the piston cutout.
- Perform the ECM initializing procedure (page 4-24) if the piston is replaced or is overhauled.



## CYLINDER STUD BOLT REPLACEMENT

If replacing the cylinder stud bolts, be sure to install them as shown.

Thread two nuts onto the stud bolt, and tighten them together, then use a wrench on them to turn the stud bolt out.

Install and tighten new stud bolts to the specified torque.

**TORQUE: 11 N·m (1.1 kgf·m, 8 lbf·ft)**

After tightening the stud bolts, check that the length from the bolt head to the crankcase surface is within specification.

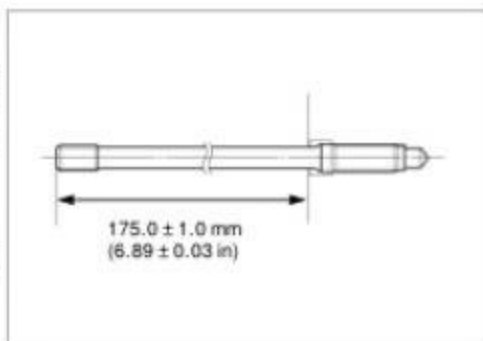

## INSPECTION

Inspect the following parts for scratch, damage, abnormal wear, deformation, burning or dogs in oil passages.

- Cylinder
- Piston
- Piston rings
- Piston pin
- Connecting rod small end

Measure each part and calculate the clearance according to CYLINDER/PISTON SPECIFICATIONS (page 1-7).

Replace any part if it is out of service limit.

---

**MEMO**

---

# 11. CLUTCH/GEARSHIFT LINKAGE

---

|                           |      |                            |       |
|---------------------------|------|----------------------------|-------|
| SERVICE INFORMATION ..... | 11-2 | RIGHT CRANKCASE COVER..... | 11-6  |
| TROUBLESHOOTING.....      | 11-4 | CLUTCH .....               | 11-7  |
| COMPONENT LOCATION .....  | 11-5 | GEARSHIFT LINKAGE.....     | 11-10 |

## CLUTCH/GEARSHIFT LINKAGE

### SERVICE INFORMATION

#### GENERAL

- This section covers service of the clutch and gearshift linkage. These service can be done with the engine installed in the frame.
- Engine oil viscosity, oil level and the use of oil additives have an effect on clutch operation. Oil additives of any kind are specifically not recommended. When the clutch does not disengage or the motorcycle creeps with clutch disengaged, inspect the engine oil and oil level before servicing the clutch system.

#### SPECIFICATIONS

Unit: mm (in)











| ITEM          |                                      | STANDARD                          | SERVICE LIMIT                     |                 |
|---------------|--------------------------------------|-----------------------------------|-----------------------------------|-----------------|
| Manual clutch | Disc thickness                       | 2.50 – 2.70 (0.099 - 0.106)       | 2.2 (0.09)                        |                 |
|               | Plate warpage                        | -                                 | 0.20 (0.008)                      |                 |
|               | Clutch spring free length            | 27.4 (1.08)                       | -                                 |                 |
|               | Clutch outer I.D.                    | 23.000 – 23.013 (0.9055 - 0.9060) | 23.06 (0.908)                     |                 |
|               | Clutch outer guide                   | I.D.                              | 16.991 – 17.009 (0.6689 - 0.6696) | 17.049 (0.6712) |
|               |                                      | O.D.                              | 22.959 – 22.980 (0.9039 - 0.9047) | 22.940 (0.9031) |
|               | Mainshaft O.D. at clutch outer guide | 16.966 – 16.984 (0.6680 - 0.6687) | 16.87 (0.66)                      |                 |

#### TORQUE VALUES

##### CLUTCH/GEARSHIFT LINKAGE

| ITEM                                 | Q'TY | THREAD DIA. (mm) | TORQUE N·m (kgf·m, lbf·ft) | REMARKS  |
|--------------------------------------|------|------------------|----------------------------|--|
| Clutch center lock nut               | 1    | 14               | 64 (6.5, 47)               | Apply engine oil to the threads and seating surface. |
| Clutch lifter plate bolt             | 3    | 6                | 12 (1.2, 9)                |  |
| Gearshift cam plate socket bolt      | 1    | 6                | 10 (1.0, 7)                | Apply locking agent to the threads.                  |
| Gearshift return spring pin          | 1    | 8                | 30 (3.1, 22)               |  |
| Oil filter rotor lock nut            | 1    | 14               | 64 (6.5, 47)               | Apply engine oil to the threads and seating surface. |
| Right crankcase cover protector bolt | 3    | 6                | 12 (1.2, 9)                |  |
| Shift drum stopper arm bolt          | 1    | 6                | 12 (1.2, 9)                | Apply locking agent to the threads.                  |

## TOOLS

|   |  |  |
|---|--|--|
| <p>Locknut Wrench 5.5 x 2.5/30 mm<br/>07716-0020100</p>                        | <p>Extension Bar/Handle<br/>07716-0020500</p>                                   | <p>Gear Holder M2.5 mm<br/>07724-0010100</p>  <p>07724-001A100 (U.S.A. only)</p>              |
| <p>Holder Fly Wheel<br/>07725-0040001</p>                                      | <p>Remover Weight<br/>07741-0010201</p>  <p>07936-371020A or 07936-3710200</p>  | <p>Pilot 12 mm<br/>07746-0040200</p>    |
| <p>Driver<br/>07749-0010000</p>   | <p>Locknut Wrench 5.5 x 30 mm<br/>07916-6390001</p>                            | <p>Bearing Remover Shaft Set, 12 mm<br/>07936-1660101</p>  <p>07936-166010A (U.S.A. only)</p> |
| <p>Remover Head, 12 mm<br/>07936-1660110</p>  <p>Not available in U.S.A.</p> | <p>Remover Shaft, 12 mm<br/>07936-1660120</p>  <p>Not available in U.S.A.</p> | <p>Attachment, 28 x 30<br/>07946-1870100</p>    |

## CLUTCH/GEARSHIFT LINKAGE

---

Remover Handle  
07936-3710100



## TROUBLESHOOTING

Faulty clutch operation can usually be corrected by adjusting the clutch system.

### Clutch slips when accelerating

- Incorrect clutch adjustment
- Worn clutch disc
- Weak clutch spring
- Faulty clutch weight
- Molybdenum or graphite additive

### Motorcycle creeps

- Faulty clutch weight
- Faulty clutch weight spring
- Incorrect idle air screw adjustment

### Hard to shift

- Damaged gearshift spindle
- Damaged stopper plate and pin
- Loose stopper plate bolt
- Incorrect clutch adjustment
- Loose gearshift cam plate bolt

### Transmission jumps out of gear

- Damaged stopper arm
- Damaged gearshift cam plate
- Loose gearshift cam plate bolt

### Gearshift pedal will not return

- Weak or broken gearshift spindle return spring
- Bent gearshift spindle

## COMPONENT LOCATION

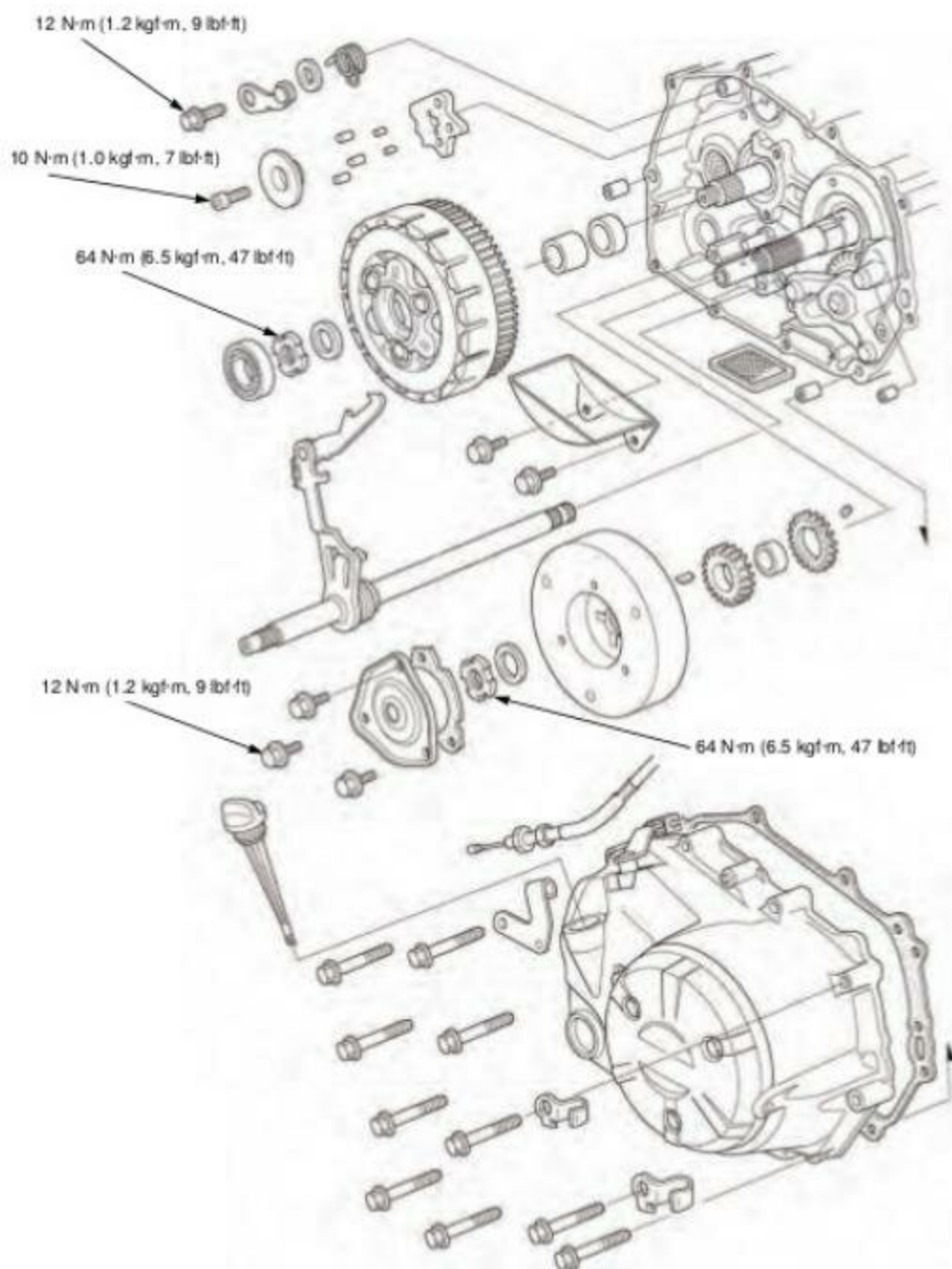

## RIGHT CRANKCASE COVER

### REMOVAL/INSTALLATION

**NOTE:**

- Clutch system can be serviced with the engine installed on the frame.

Drain the engine oil.

Remove the right step holder.

Loosen the bolts [1] in a crisscross pattern in several steps.

Remove the bolts, two clamps [2] and right crankcase cover.

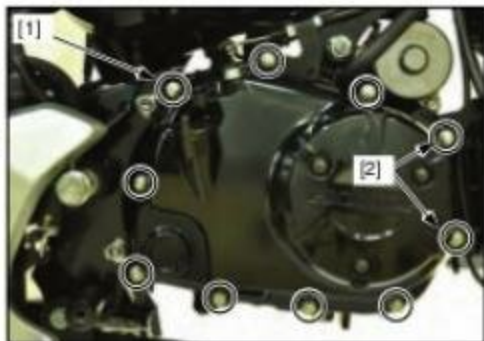

Remove the dowel pins [1], orifice [2] and gasket [3].  
Installation is in the reverse order of removal.

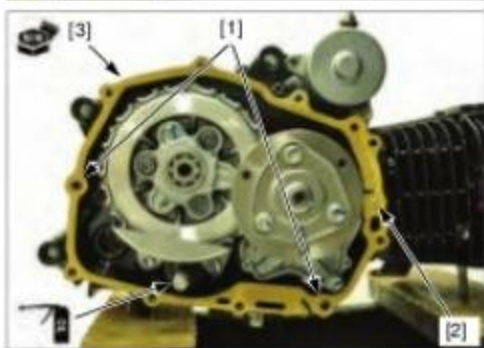

### RIGHT CRANKCASE COVER PROTECTOR

Remove the three bolts [1] and right crankcase cover protector.

Installation is in the reverse order of removal.

**TORQUE: Right crankcase cover protector bolt**  
12 N·m (1.2 kgf·m, 9 lbf·ft)

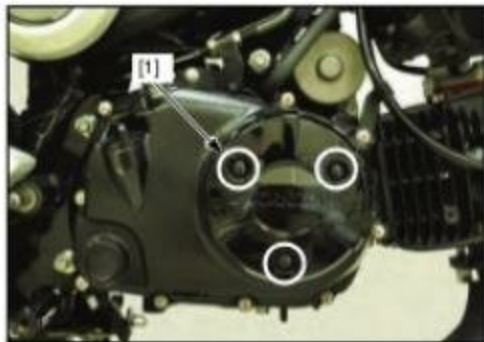

## CRANKSHAFT BEARING REPLACEMENT

Remove the crankshaft bearing [1] using the special tools as shown.

### TOOLS:

|                               |               |
|-------------------------------|---------------|
| [2] Bearing remover set, 12mm | 07936-1660101 |
| Bearing remover shaft, 12 mm  | 07936-1660120 |
| Bearing remover head, 12mm    | 07936-1660110 |
| [3] Remover weight            | 07741-0010201 |

### U.S.A. TOOLS:

|                        |                                   |
|------------------------|-----------------------------------|
| Bearing remover, 12 mm | 07936-166010A                     |
| Remover weight         | 07936-371020A or<br>07936-3710200 |
| Bearing handle         | 07936-3710100                     |

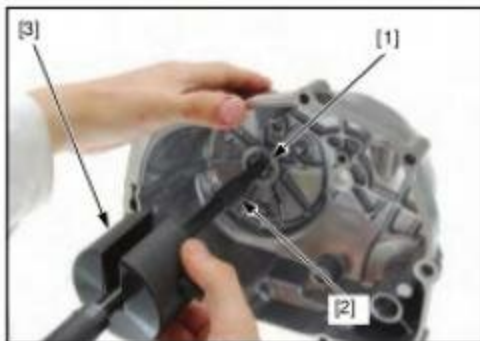

Install a new crankshaft bearing [1] with its sealed side facing down until it is fully seated using the special tools.

### TOOLS:

|                            |               |
|----------------------------|---------------|
| [2] Driver                 | 07749-0010000 |
| [3] Attachment, 28 x 30 mm | 07946-1870100 |
| [4] Pilot, 12 mm           | 07746-0040200 |

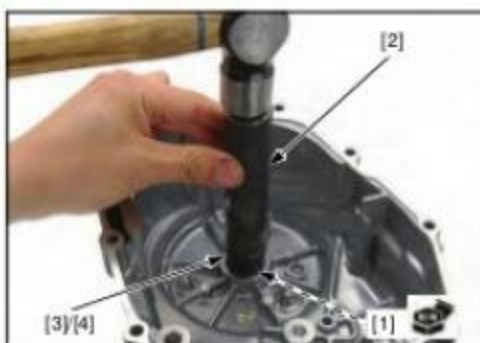

## CLUTCH

### REMOVAL/INSTALLATION

#### NOTE:

- Clutch system can be serviced with the engine installed on the frame.

Remove the following:

- Right crankcase cover (page 11-6)
- Centrifugal oil filter (page 8-5)

Hold the primary drive and driven gear, then remove the centrifugal filter rotor lock nut using the special tools.

#### TOOLS:

|                                  |  |
|----------------------------------|--|
| [1] Lock nut wrench, 5.5 x 30 mm | 07916-6390001                                      |
| [2] Gear holder 2.5mm            | 07724-0010100 or<br>07724-001A100<br>(U.S.A. only) |

Remove the washer and centrifugal filter rotor.

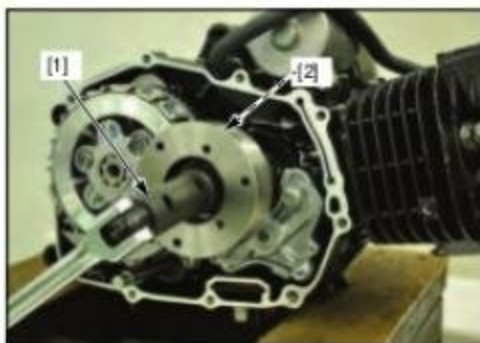

## CLUTCH/GEARSHIFT LINKAGE

Remove the clutch lifter bearing.

If the bearing cannot be removed by hand, use the tools listed below and replace the bearing upon reinstallation.

**TOOLS:**

|                       |               |
|-----------------------|---------------|
| Bearing remover, 10mm | 07936-GEOA000 |
| Remover handle        | 07736-3710100 |
| Remover weight        | 07736-371020A |

Hold the primary drive and driven gear, then remove the clutch center lock nut [1] using the special tools then remove the washer [2].

**TOOLS:**

|                                 |   |
|---------------------------------|---|
| Gear holder 2.5mm               | 07724-0010100 or<br>07724-001A100<br>(U.S.A. only)      |
| [3] Lock nut wrench, 20 x 24 mm | 07716-0020100   |
| [4] Extension bar               | 07716-0020500 or<br>commercially<br>available in U.S.A. |

Remove the bolts [5] then remove the clutch assembly and oil separator plate [6].

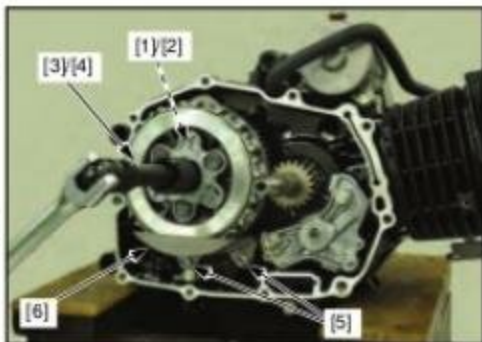

Remove the clutch outer guide [1] and collar [2] from the mainshaft.

Remove the primary drive gear [3], woodruff key, and spacer from the crankshaft.

Installation is in the reverse order of removal.

- Apply engine oil to the each gear and collar.
- Apply engine oil to the clutch center lock nut and centrifugal filter rotor lock nut threads and seating surface then tighten it to the specified torque using the special tools.

**TORQUE:**

|                                      |                                  |
|--------------------------------------|----------------------------------|
| Clutch center lock nut               | 64 N·m (6.5 kgf·m,<br>47 lbf·ft) |
| Centrifugal filter rotor<br>lock nut | 64 N·m (6.5 kgf·m,<br>47 lbf·ft) |

### MANUAL CLUTCH DISASSEMBLY/ ASSEMBLY

Hold the clutch outer using the special tool and loosen the bolts [1] in several steps.

**TOOL:**

|                     |               |
|---------------------|---------------|
| [2] Flywheel holder | 07725-0040001 |
|---------------------|---------------|

Remove the bolts, clutch lifter plate [3] and clutch springs [4].

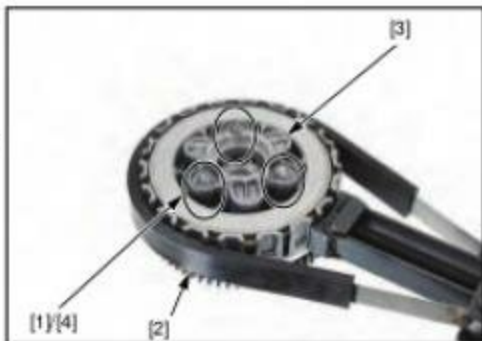

Remove the clutch center assembly from the clutch outer.

Remove the following:

- Clutch center
- Clutch discs
- Clutch plates
- Springs

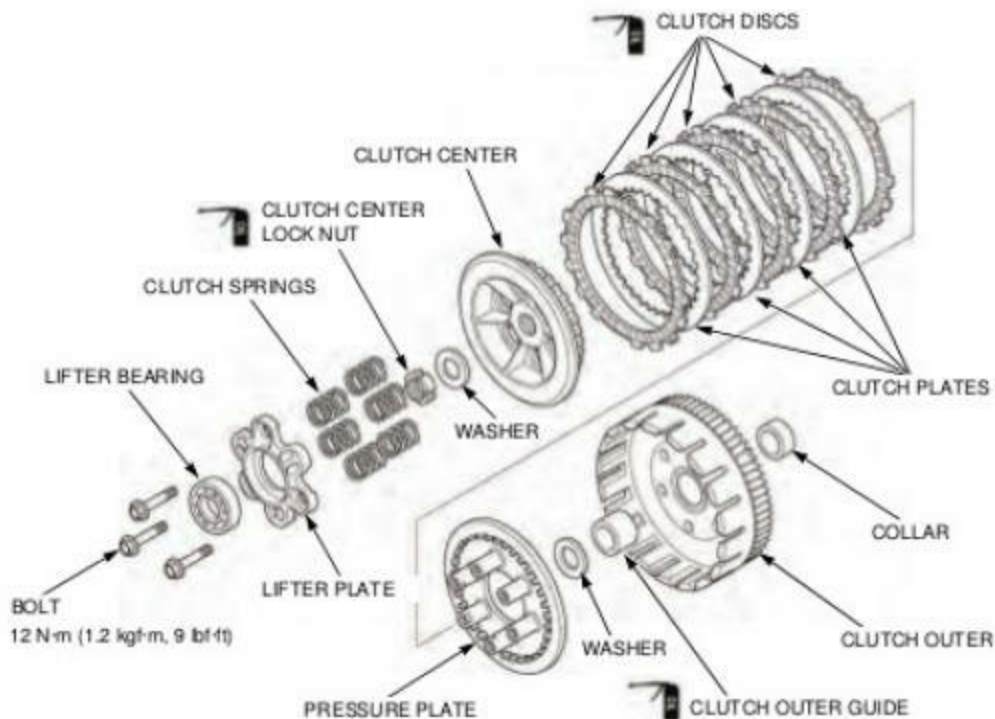

### INSPECTION

Inspect the following parts for scratch, damage, abnormal wear and deformation. Replace if necessary.

- Clutch lifter bearing
- Clutch springs
- Clutch center
- Clutch discs/plates
- Clutch outer
- Clutch outer guide
- Mainshaft
- Centrifugal filter rotor
- Primary drive gear (page 13-7)

Measure each part according to CLUTCH/GEARSHIFT LINKAGE SPECIFICATIONS (page 1-8).

Replace any part if it is out of service limit.

- Replace the clutch springs as a set.
- Replace the clutch discs and plates as a set.

**GEARSHIFT LINKAGE****REMOVAL**

Remove the following:

- Clutch (page 11-7)
- Gearshift pedal (page 12-4)

Clean the gearshift spindle thoroughly to prevent the dirt or dust from entering the engine.

Remove the gearshift spindle [1] by holding down the gearshift arm [2] as shown.

Remove the gearshift cam plate bolt [3] and washer [4].



Lower and hold the stopper arm [1], then remove the gearshift cam plate [2].

Remove the gearshift drum pins [3].

Remove the bolt, stopper arm, washer [4] and return spring [5].

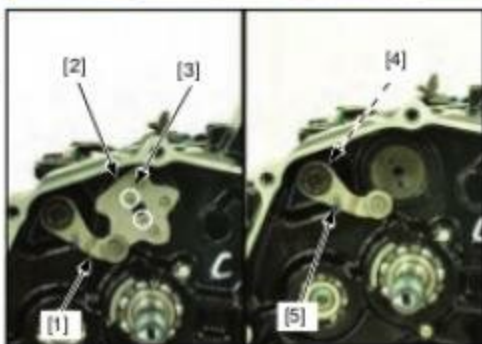
**INSPECTION**

Inspect the following parts for scratch, damage, abnormal wear and deformation. Replace if necessary.

- Gearshift spindle
- Gearshift arm spring
- Gearshift arm
- Gearshift spindle oil seal

Measure each part according to CLUTCH/GEARSHIFT LINKAGE SPECIFICATIONS (page 1-8).

Replace any part if it is out of service limit.

## INSTALLATION

Apply grease to the gearshift spindle oil seal [1] lips.



Apply locking agent to the threads of the shift drum stopper arm bolt [1].

Install the return spring [2], washer [3], stopper arm [4] and bolt.

Tighten the shift drum stopper arm bolt to the specified torque.

**TORQUE: 12 N·m (1.2 kgf·m, 9 lbf·ft)**

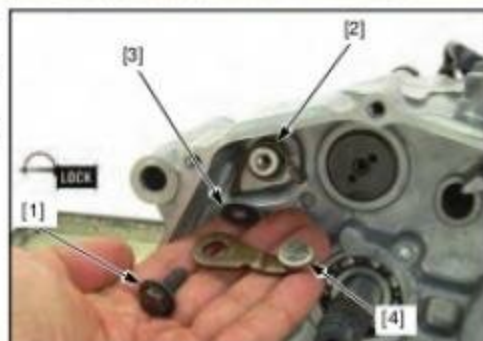

Install the gearshift drum pins [1] into the holes on the gearshift drum.

Hold the stopper arm [2] then install the gearshift cam plate [3] by aligning the holes in the plate with the gearshift drum pins.

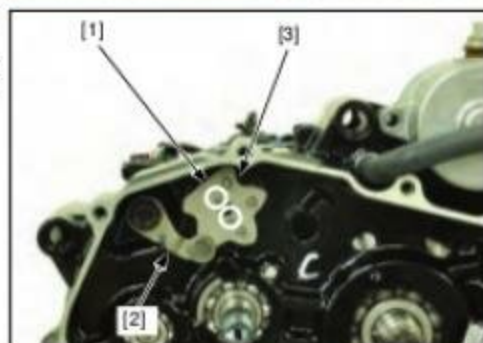

Apply locking agent to the threads of the gearshift cam plate socket bolt [1].

Install the washer [2] and bolt.

Tighten the bolt to the specified torque.

**TORQUE: 10 N·m (1.0 kgf·m, 7 lbf·ft)**

*Be careful not to damage the oil seal.*

Install the gearshift spindle [3] by aligning its return spring ends with the shift return spring pin.

Install the following:

- Clutch (page 11-7)
- Gearshift pedal



---

**MEMO**

---

## 12. ALTERNATOR/STARTER CLUTCH

---

|                            |      |                               |      |
|----------------------------|------|-------------------------------|------|
| SERVICE INFORMATION .....  | 12-2 | STATOR .....                  | 12-4 |
| COMPONENT LOCATION .....   | 12-3 | FLYWHEEL/STARTER CLUTCH ..... | 12-5 |
| LEFT CRANKCASE COVER ..... | 12-4 |                               |      |

## ALTERNATOR/STARTER CLUTCH

### SERVICE INFORMATION

#### GENERAL

- These services can be done with the engine installed in the frame.

#### SPECIFICATIONS

Unit: mm (in)

| ITEM                          | STANDARD                          | SERVICE LIMIT   |
|-------------------------------|-----------------------------------|-----------------|
| Starter driven gear boss O.D. | 45.660 – 45.673 (1.7976 - 1.7981) | 45.642 (1.7969) |

#### TORQUE VALUES

##### ALTERNATOR

| ITEM         | Q'TY | THREAD DIA. (mm) | TORQUE N-m (kgf-m, lbf-ft) | REMARKS  |
|--------------|------|------------------|----------------------------|--|
| Flywheel nut | 1    | 12               | 64 (6.5, 47)               | Apply engine oil to the threads and seating surface. |

#### TOOLS

|   |   |
|---|---|
| Holder Fly Wheel<br>07725-0040001   | Inside Screw Puller 30 x 1.5<br>07KMC-HE00100                                     |
|  |  |

## COMPONENT LOCATION

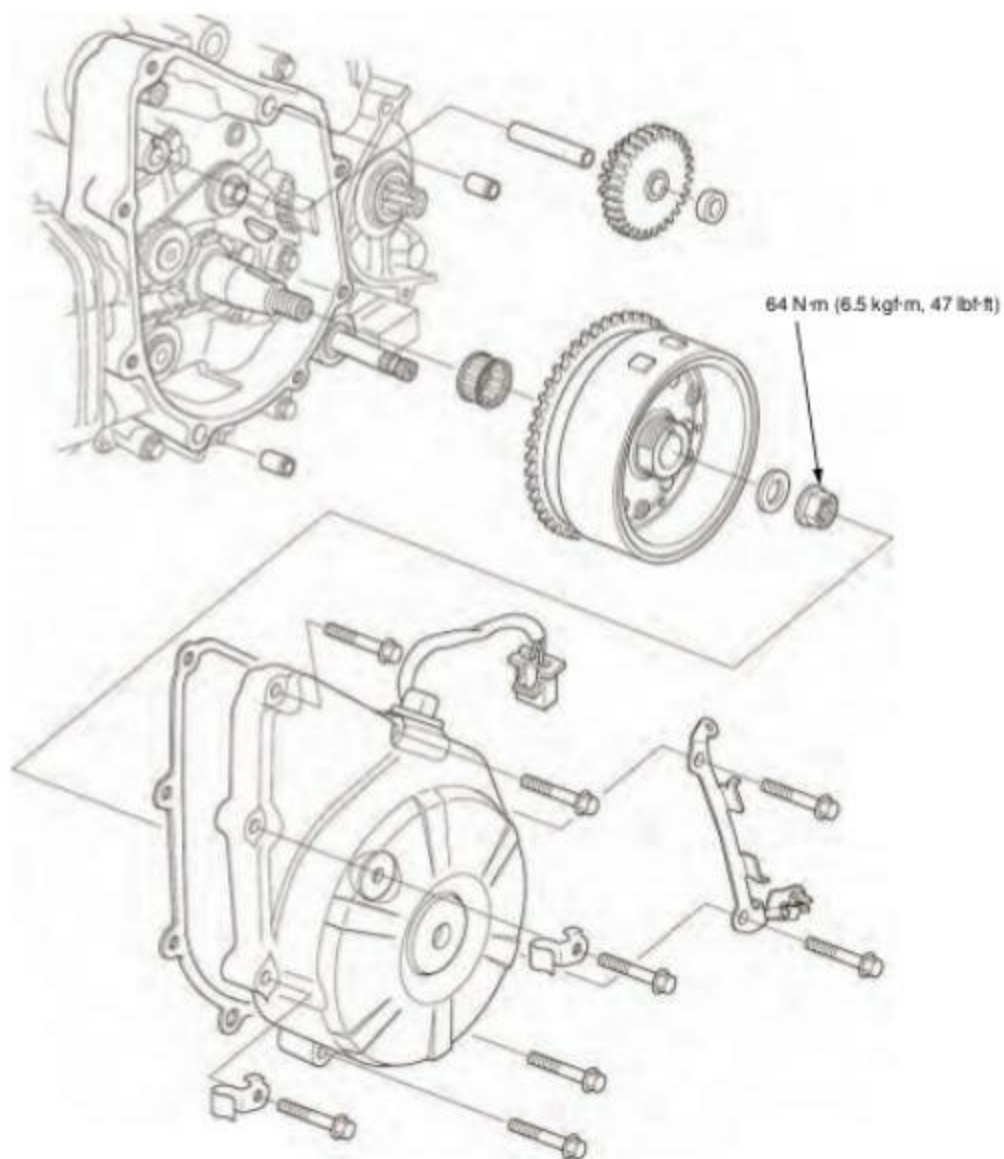

## ALTERNATOR/STARTER CLUTCH

### LEFT CRANKCASE COVER

- Alternator/starter clutch can be serviced with the engine installed on the frame.

#### REMOVAL/INSTALLATION

Drain the engine oil (page 3-7).

Remove the following:

- Left shroud (page 2-4)
- Gearshift pedal

Disconnect the alternator 4P connector.

Loosen the bolts [1] in a crisscross pattern in several steps.

Remove the bolts and EOT sensor wire dampers [2].

Remove the left crankcase cover [3].

#### NOTE:

The left crankcase cover (stator) is magnetically attached to the flywheel, be careful during removal.



Remove the gasket [1] and dowel pins [2].

Installation is in the reverse order of removal.

- Apply engine oil to the starter reduction gear journal [3].
- Install the gearshift pedal arm onto the gearshift spindle, while aligning its slit with the punch mark.

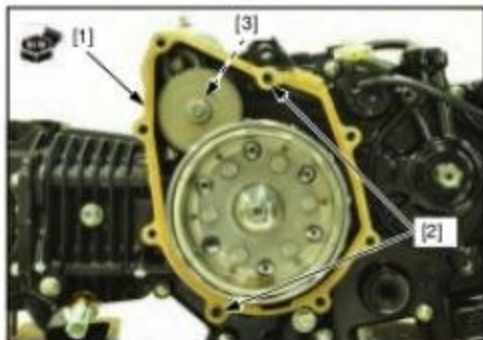

### STATOR

#### REMOVAL/INSTALLATION

Remove the left crankcase cover (page 12-4).

Remove the CKP sensor mounting bolts [1] and release the wire grommet [2] from the left crankcase cover.



Remove the stator mounting bolts [1], then remove the stator [2] from the left crankcase cover.

Installation is in the reverse order of removal.

- Apply liquid sealant (THREE BOND 1215/1207B or equivalent) to the wire grommet seating surface and install the grommet into the cover groove.



## FLYWHEEL/STARTER CLUTCH

### REMOVAL

Remove the left crankcase cover (page 12-4).

Remove the shaft [1], collar [2] and starter reduction gear [3].

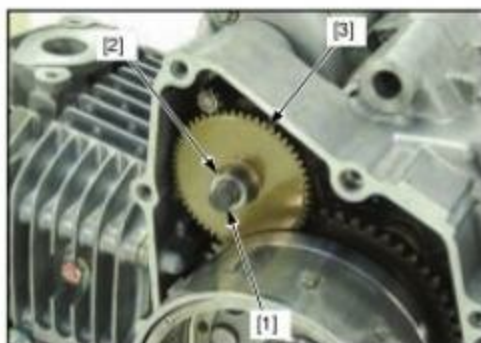

Remove the flywheel nut [1] and washer [2] using the special tool.

**TOOL:**

[3] Flywheel holder

07725-0040001



Remove the flywheel/starter clutch [1] using the special tool.

**TOOL:**

[2] Flywheel puller, 30 mm

07KMC-HE00100



## ALTERNATOR/STARTER CLUTCH

Remove the needle bearing [1].  
Remove the woodruff key [2].

*During woodruff key removal/installation, be careful not to damage the key groove or crankshaft.*

### INSTALLATION

Install the woodruff key in the crankshaft key groove.

Apply engine oil to the starter clutch rolling surface of the crankshaft and needle bearing whole surface.  
Install the needle bearing to the crankshaft.

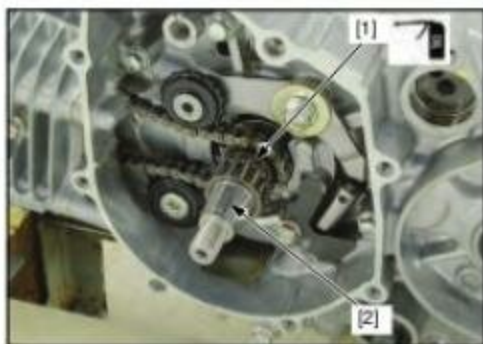

Wipe any oil off the mating surface of the crankshaft and flywheel.

Install the flywheel/starter clutch [1] to the crankshaft, aligning the key way with the woodruff key.



Install the washer [1].  
Apply engine oil to the flywheel nut [2] threads and seating surface, then install it.  
Hold the flywheel using the special tool and tighten the flywheel nut to the specified torque.

#### TOOL:

[3] Flywheel holder 07725-0040001

**TORQUE:** 64 N·m (6.5 kgf·m, 47 lbf·ft)



Apply engine oil to the starter reduction gear [1] journal area and gear teeth.  
Install the starter reduction gear by aligning with the starter drive gear [2] and starter driven gear [3].

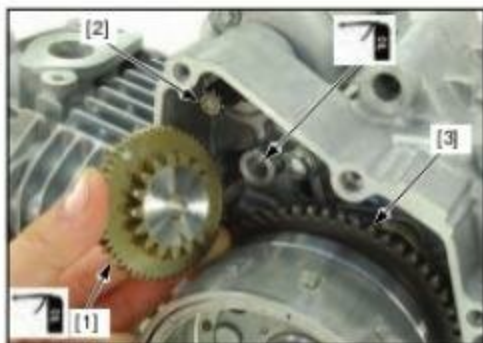

Apply engine oil to the starter reduction gear shaft [1] whole surface.  
 Install the shaft and collar [2] into the reduction gear.  
 Install the left crankcase cover (page 12-4).

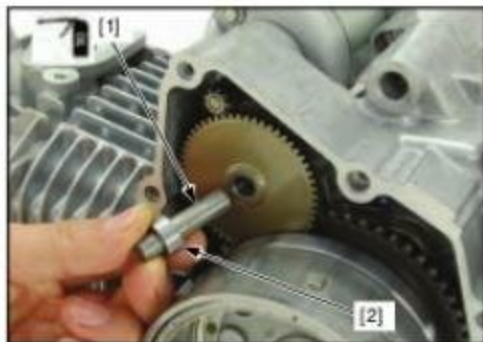

**STARTER CLUTCH DISASSEMBLY**

Check the operation of the one way clutch by turning the driven gear.  
 You should be able to turn the driven gear [1] counterclockwise smoothly, but the gear should not turn clockwise.

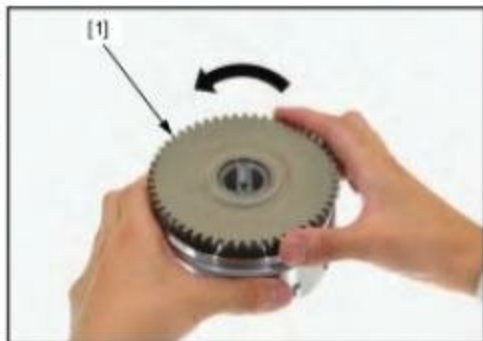

Remove the starter driven gear from the flywheel/starter clutch while turning the driven gear counterclockwise.

Hold the flywheel using the special tool and remove the starter clutch outer mounting torx bolts [1].

**TOOL:**  
 [2] Flywheel holder 07725-0040001

Remove the starter clutch assembly [3].



Remove the starter clutch cover [1], rollers [2] and springs [3] from the starter clutch outer [4].

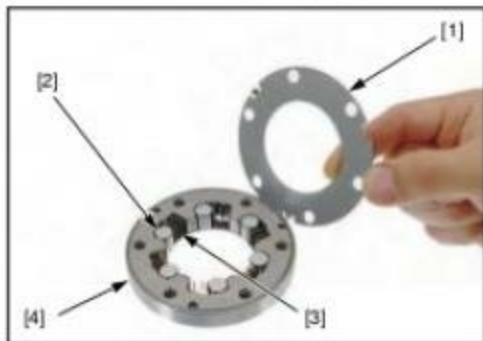

## ALTERNATOR/STARTER CLUTCH

### INSPECTION

Inspect the following parts for scratch, damage, abnormal wear and deformation. Replace if necessary.

- Starter driven gear
- Rollers, springs and starter clutch outer
- Starter reduction gear and shaft
- Starter driven gear needle bearing

Measure each part according to ALTERNATOR/STARTER CLUTCH SPECIFICATIONS (page 1-8).  
Replace any part if it is out of service limit.

### STARTER CLUTCH ASSEMBLY

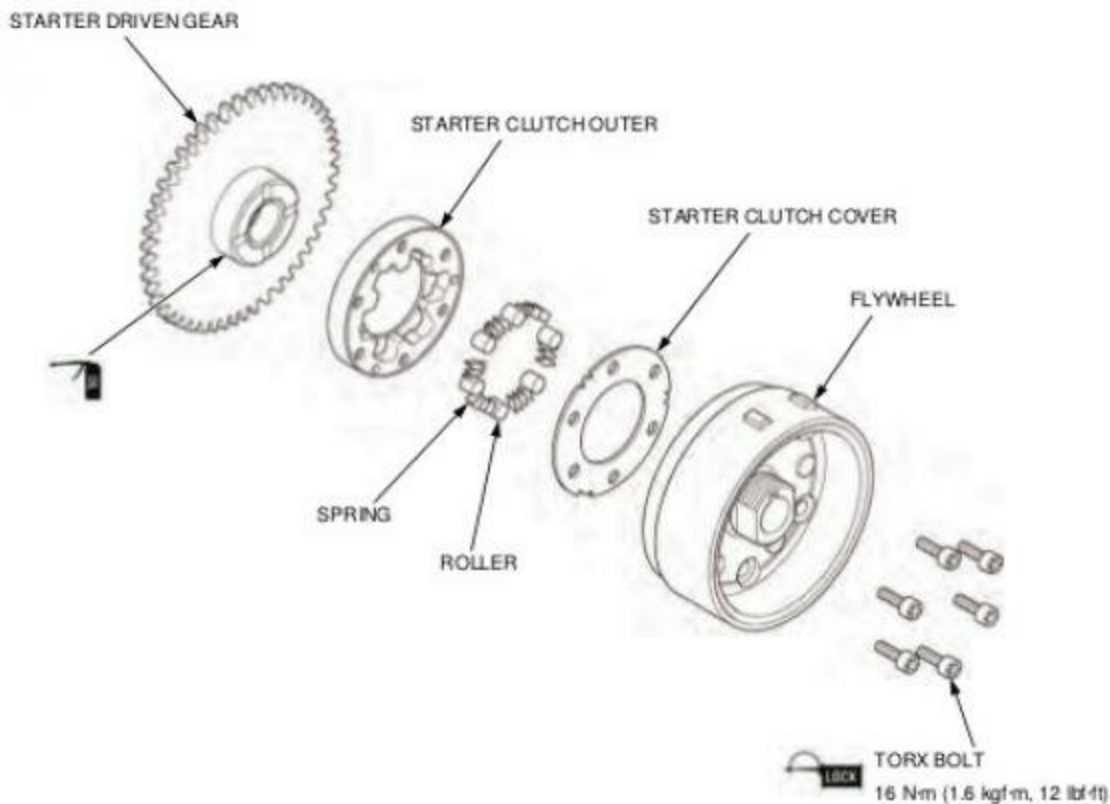

Install the springs [1] and rollers [2] into the starter clutch outer [3] as shown.

Install the starter clutch cover [4] while aligning its tabs with the holes in the starter clutch outer.

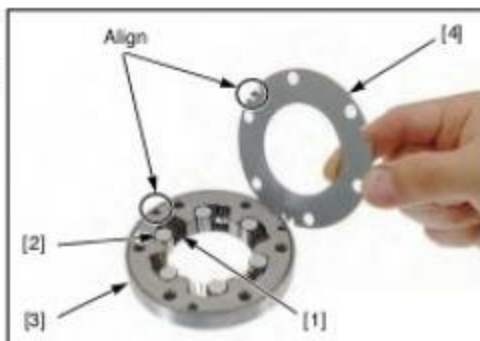

Install the starter clutch assembly [1] onto the flywheel [2].

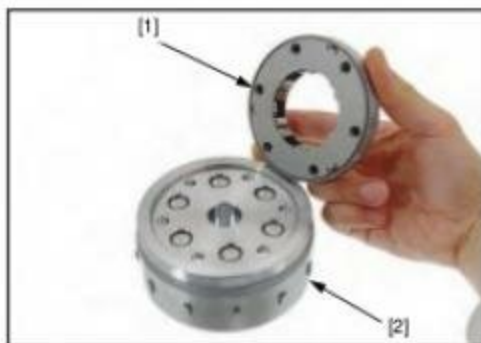

Apply locking agent to the starter clutch outer mounting torx bolt [1] threads as specified.  
Hold the flywheel using the special tool and tighten the bolts to the specified torque.

**TOOL:**  
[2] Flywheel holder 07725-0040001

**TORQUE:** 16 N·m (1.6 kgf·m, 12 lbf·ft)



Apply engine oil to the starter clutch rolling surface of the driven gear [1].



Install the starter driven gear [1] to the flywheel/starter clutch while turning it counterclockwise.

Make sure that the starter driven gear turns counterclockwise smoothly and does not turn clockwise.

Install the flywheel/starter clutch (page 12-6).

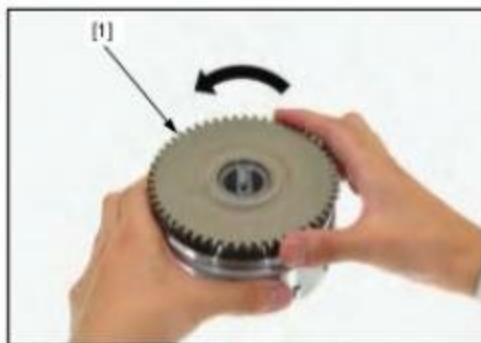

---

**MEMO**

---

# **13. CRANKCASE/TRANSMISSION/CRANKSHAFT**

---

|                                  |             |                           |              |
|----------------------------------|-------------|---------------------------|--------------|
| <b>SERVICE INFORMATION .....</b> | <b>13-2</b> | <b>CRANKCASE .....</b>    | <b>13-6</b>  |
| <b>TROUBLESHOOTING.....</b>      | <b>13-4</b> | <b>CRANKSHAFT .....</b>   | <b>13-7</b>  |
| <b>COMPONENT LOCATION .....</b>  | <b>13-5</b> | <b>TRANSMISSION .....</b> | <b>13-10</b> |

## SERVICE INFORMATION

### GENERAL

- The crankcase must be separated to service the crankshaft, transmission.
- The following parts must be removed before separating the crankcase.
  - Engine (page 14-4)
  - Cylinder head (page 9-9)
  - Cam chain tensioner (page 9-15)
  - Flywheel (page 12-5)
  - Clutch/gearshift linkage (page 11-7)
  - Cylinder/piston (page 10-3)
  - Oil pump (page 8-4)
  - Starter motor (page 6-4)
  - Gear position switch (page 19-10)
- Be careful not to damage the crankcase mating surfaces when servicing.
- Prior to assembling the crankcase halves, apply sealant to the mating surface. Wipe off excess sealant thoroughly.

### SPECIFICATIONS







Unit: mm (in)

| ITEM                      |                                 | STANDARD                        | SERVICE LIMIT                     |               |
|---------------------------|---------------------------------|---------------------------------|-----------------------------------|---------------|
| Crankshaft                | Connecting rod side clearance   | 0.10 – 0.35 (0.004 - 0.0138)    | 0.60 (0.024)                      |               |
|                           | Connecting rod radial clearance | 0.004 – 0.016 (0.0002 - 0.0006) | 0.05 (0.002)                      |               |
|                           | Runout                          | –                               | 0.10 (0.004)                      |               |
| Transmission              | Gear I.D.                       | M2, M3                          | 17.000 – 17.018 (0.6693 - 0.6700) |               |
|                           |                                 | C1                              | 18.000 – 18.018 (0.7087 - 0.7094) |               |
|                           |                                 | C4                              | 20.000 – 20.021 (0.7874 - 0.7882) |               |
|                           | Bushing O.D.                    | C1                              | 17.966 – 17.984 (0.7073 - 0.7080) | 17.94 (0.706) |
|                           | Bushing I.D.                    | C1                              | 15.000 – 15.018 (0.5906 - 0.5913) | 15.04 (0.592) |
|                           | Gear-to-bushing clearance       | C1                              | 0.016 – 0.052 (0.0006 - 0.0020)   | 0.10 (0.004)  |
|                           | Mainshaft O.D.                  | at M3                           | 16.966 – 16.984 (0.6680 - 0.6687) | 16.95 (0.667) |
|                           | Countershaft O.D.               | at C1 bushing                   | 14.966 – 14.984 (0.5892 - 0.5899) | 14.95 (0.589) |
|                           | Gear-to-shaft clearance         | M3                              | 0.016 – 0.052 (0.0006 - 0.0020)   | 0.09 (0.004)  |
|                           | Bushing-to-shaft clearance      | C1                              | 0.016 – 0.052 (0.0006 - 0.0020)   | 0.09 (0.004)  |
| Shift fork/<br>Shift drum | Shift fork I.D.                 |                                 | 10.000 – 10.018 (0.3937 - 0.3944) | 10.07 (0.397) |
|                           | Shift fork claw thickness       |                                 | 4.93 – 5.00 (0.194 - 0.197)       | 4.90 (0.193)  |
|                           | Shift fork shaft O.D.           |                                 | 9.986 – 9.995 (0.3931 - 0.3935)   | 9.93 (0.391)  |
|                           | Shift drum journal I.D.         | Left                            | 24.000 – 24.033 (0.9449 - 0.9462) | 24.07 (0.948) |
|                           |                                 | Right                           | 28.000 – 28.021 (1.1024 - 1.1032) | 28.08 (1.106) |

**TOOLS**

|  |   |  |
|--|---|--|
| <p>Bearing Separator Set<br/>07631-0010000</p>  <p>Commercially available in U.S.A.</p> | <p>Remover Weight<br/>07741-0010201</p>  <p>07936-371020A or 07936-3710200<br/>U.S.A. only</p> | <p>Attachment, 32 x 35 mm<br/>07746-0010100</p>   |
| <p>Attachment, 37 x 40 mm<br/>07746-0010200</p>   | <p>Attachment, 52 x 55 mm<br/>07746-0010400</p>    | <p>Pilot 12 mm<br/>07746-0040200</p>    |
| <p>Pilot 17 mm<br/>07746-0040400</p>   | <p>Pilot 22 mm<br/>07746-0041000</p>    | <p>Driver<br/>07749-0010000</p>   |
| <p>Special Nut<br/>07931-HB3020A</p>    | <p>Installer Shaft<br/>07931-ME4010B</p>   | <p>Bearing Remover Shaft Set, 12 mm<br/>07936-1660101</p>  <p>07936-1660100A U.S.A. only</p> |

## CRANKCASE/TRANSMISSION/CRANKSHAFT

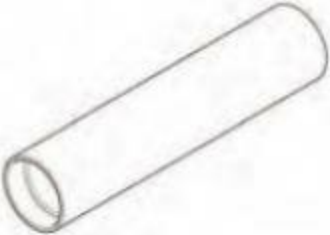
|   |  |   |
|---|--|---|
| <p>Remover Head, 12 mm<br/>07936-1660110</p>  <p>Not available in the U.S.A.</p> | <p>Remover Shaft, 12 mm<br/>07936-1660120</p>  <p>Not available in the U.S.A.</p> | <p>Remover Handle<br/>07936-3710100</p>                 |
| <p>Attachment, 28 x 30<br/>07946-1870100</p>                                     | <p>Threaded adapter<br/>07AMF-K26A100</p>   | <p>Shaft/Case Disassembly Set 14<br/>07JMF-KW70100</p>  |
| <p>Collar 30.1 x 34 x 15 mm<br/>07YMF-KPB0100</p>                                |  |   |

## TROUBLESHOOTING

### Hard to shift

- Incorrect clutch adjustment
- Bent shift forks
- Bent gearshift spindle
- Damaged shift drum cam grooves
- Incorrect engine oil viscosity

### Transmission jumps out of gear

- Worn gear dogs and dog holes
- Broken shift drum stopper arm
- Broken drum stopper arm spring
- Broken gearshift spindle return spring
- Worn or bent shift forks
- Worn gear shifter groove

### Excessive noise

- Worn connecting rod big end bearing
- Worn crankshaft bearing
- Worn transmission bearing
- Worn or damaged transmission gears

## COMPONENT LOCATION

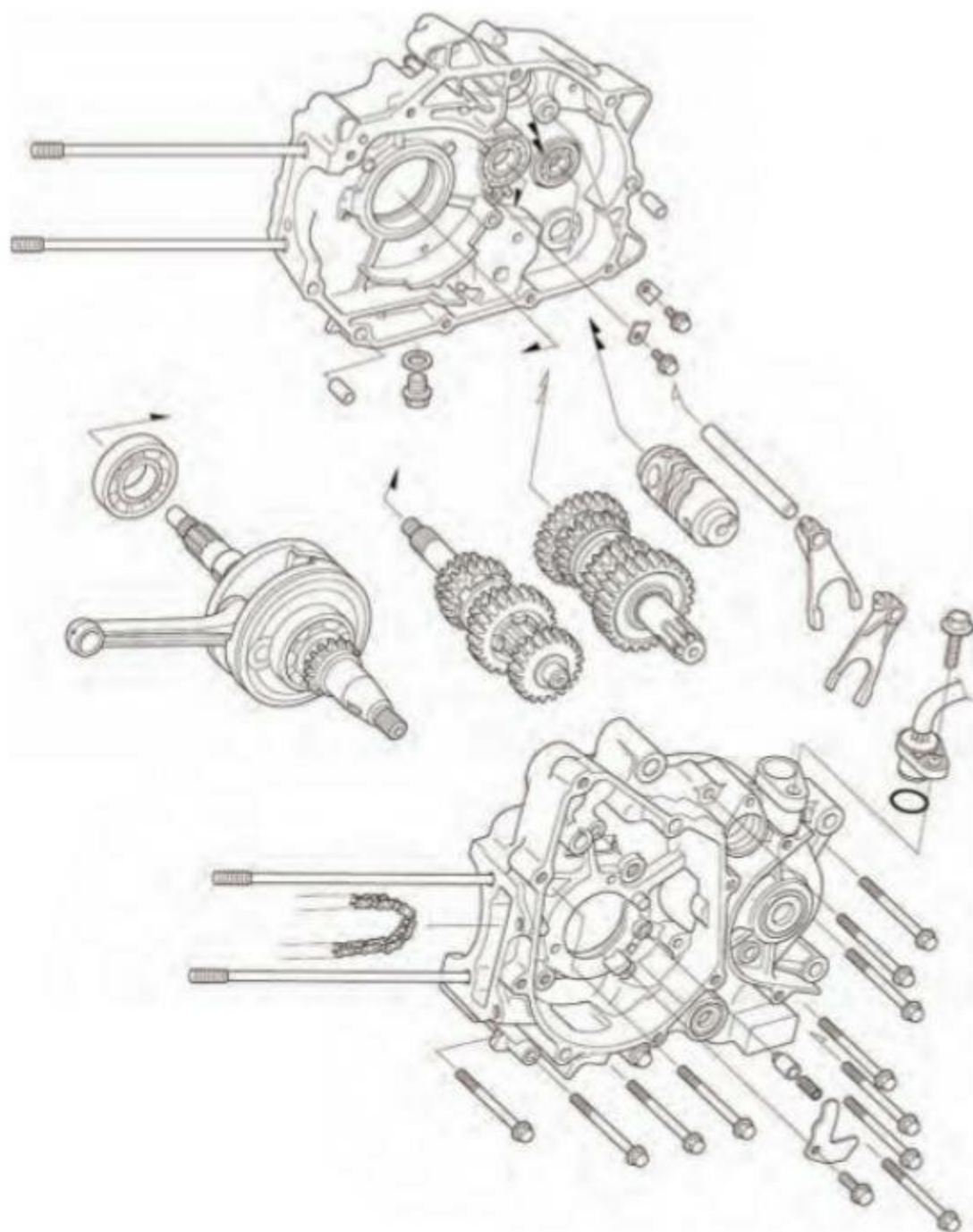

**CRANKCASE****SEPARATION/ASSEMBLY**

Refer to Service Information (page 13-2) for removal of necessary parts before separating the crankcase.

Remove the cam chain [1] from the timing sprocket.

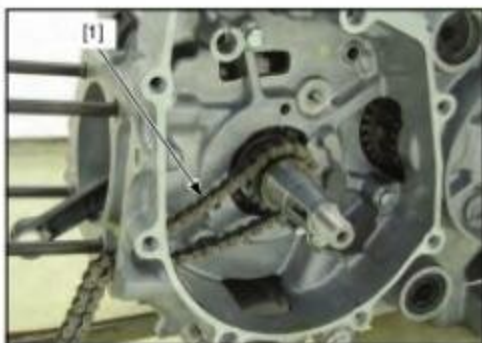

Remove the bolt [1], holder plate [2], spring [3] and bearing push plug [4].

Loosen and remove the crankcase bolts [5] in a crisscross pattern in several steps.

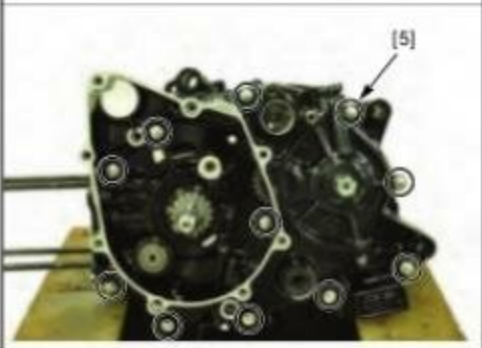
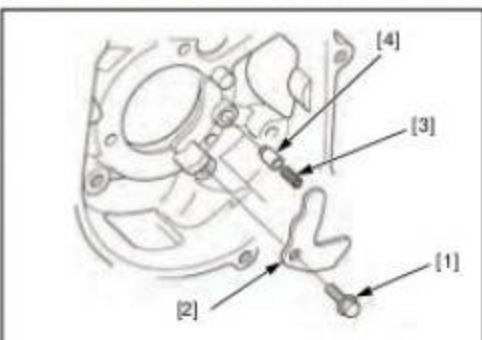

Place the left crankcase [1] up.

Carefully separate the left crankcase from the right crankcase [2] while tapping them at several locations with a soft hammer.

Remove the dowel pins.

Clean off the sealant from the left and right crankcase mating surfaces.

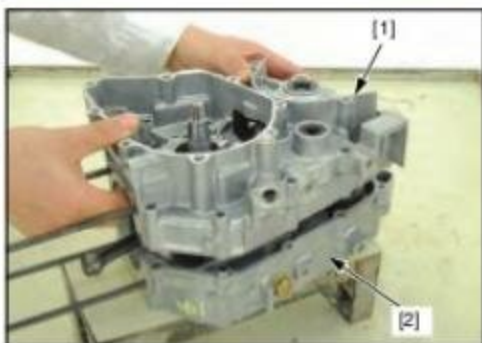

**CRANKCASE SEALANT**

Clean off the sealant from the left and right crankcase mating surfaces.

Install the dowel pins to the right crankcase.

Apply light but thorough coating of sealant (THREE BOND 1215/1207B or equivalent) to the left crankcase mating surface except the oil passage area as shown. Mate the crankcase halves, install the bolts, and tighten them in a crisscross pattern.

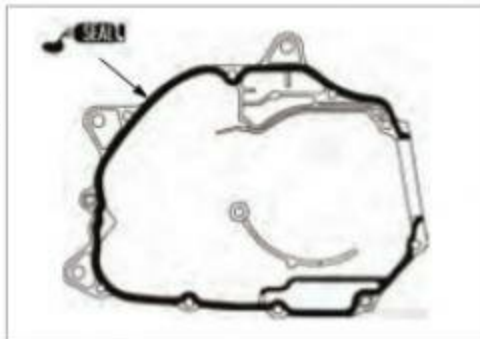
**PRIMARY DRIVE GEAR SELECTION**

The primary drive gear has ID mark [1] on the gear surface.

If the primary drive gear is replaced with a new one, select the same marked gear as the original gear.

If the crankcase replaced a new one, select the "B" marked gear.

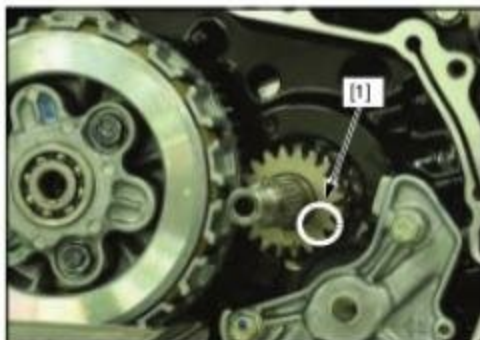
**CRANKSHAFT****REMOVAL**

Remove the transmission (page 13-10).

Remove the oil pump drive gear.

*Be careful not to drop the crankshaft.* Remove the crankshaft [1] from the right crankcase [2] using a hydraulic press.



## CRANKCASE/TRANSMISSION/CRANKSHAFT

If the crankshaft bearing [1] remains on the crankshaft, remove it using a special tool as shown.

### TOOL:

[2] Universal bearing puller 07631-0010000  
or equivalent  
commercially  
available

### U.S.A. TOOLS:

Installer shaft 07931-ME4010B  
Special nut 07931-HB3010A  
Threaded adapter 07AMF-K26A100  
Assembly collar 07YMF-KPB0100



If the bearing [1] remains in the right crankcase, drive it out from the outside.

*Do not reuse the crankshaft bearing.*

Discard the crankshaft bearing.



## INSPECTION

Inspect the following parts for scratch, damage, abnormal wear and deformation. Replace if necessary.

- Connecting rod
- Timing sprocket

Measure each part according to CRANKCASE/CRANKSHAFT/TRANSMISSION BALANCER SPECIFICATIONS (page 1-8).

Replace any part if it is out of service limit.

### SIDE CLEARANCE

Measure the side clearance by inserting the feeler gauge [1] between the crankshaft and connecting rod big end.

**SERVICE LIMIT: 0.60 mm (0.024 in)**



**RADIAL CLEARANCE**

Set the crankshaft on V-blocks and measure the connecting rod big end radial clearance.

**SERVICE LIMIT: 0.05 mm (0.002 in)**



**CRANKSHAFT**

Place the crankshaft on a stand or V-blocks and measure the runout using a dial gauge.

The measuring locations are shown in the illustration.

**SERVICE LIMIT: 0.10 mm (0.004 in)**

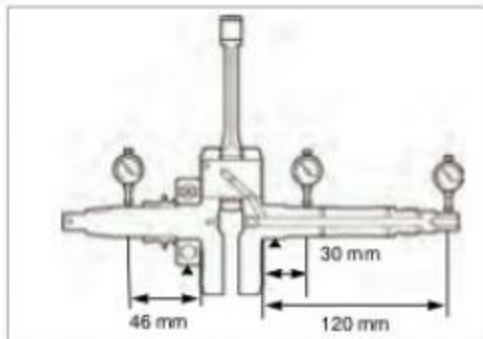

Check the timing sprocket [1] for wear or damage.

Turn the outer race of the left crankshaft bearing [2] with your finger.

The bearing should turn smoothly and quietly.

Also check that the bearing inner race fits tightly on the crankshaft.

Replace the crankshaft if the outer race does not turn smoothly, quietly, or if inner race fits loosely on the crankshaft.



**CRANKSHAFT BEARING REPLACEMENT**

Apply oil to a new right crankshaft bearing [1] rolling surface.

*Be careful not to damage the crankcase.*

Drive in the right crankshaft bearing with its marked side facing up until it is fully seated, using the special tools.

**TOOLS:**

- [2] Driver 07749-0010000
- [3] Attachment, 52 x 55 mm 07746-0010400
- [4] Pilot, 22 mm 07746-0041000

For transmission bearing replacement (page 13-13).

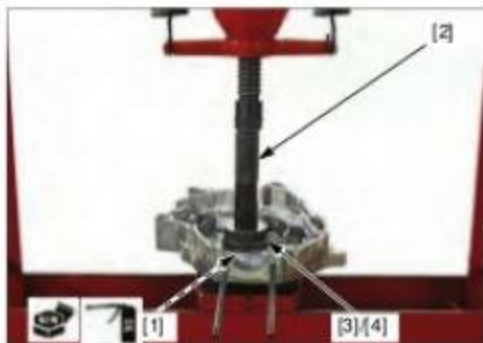

## CRANKCASE/TRANSMISSION/CRANKSHAFT

### INSTALLATION

Apply 1 – 2 cm<sup>3</sup> of oil to the connecting rod [1] big end.

*Be sure that the connecting rod is located in the crankcase opening.*

Draw the crankshaft [2] into the right crankcase [3] bearing inner race using the special tool.

#### TOOL:

[4] Assembly set, 14 mm      07JMF-KW70100

#### U.S.A. TOOLS:

Install the transmission (page 13-10).

Assemble the crankcase (page 13-6).

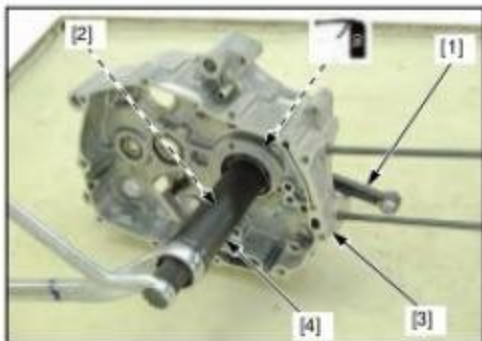

## TRANSMISSION

### REMOVAL/INSTALLATION

Separate the crankcase (page 13-6).

Remove the gearshift linkage (page 11-10)

Remove the shift fork shaft [1], shift forks [2] and shift drum [3].

Remove the mainshaft and countershaft as an assembly.



Remove the countershaft oil seal [1] from the left crankcase.



**INSPECTION**

Inspect the following parts for scratch, damage, abnormal wear and deformation. Replace if necessary.

- Transmission gears
- Transmission bushings
- Transmission bearings
- Shift drum/journal
- Shift forks
- Shift fork shaft
- Mainshaft
- Countershaft
- Gear shift spindle journal
- Oil passages

Measure each part and calculate the clearance according to CRANKCASE/CRANKSHAFT/TRANSMISSION/BALANCER SPECIFICATIONS (page 1-8).

Replace any part if it is out of service limit.

**ASSEMBLY**

Clean all parts in solvent and dry them thoroughly.

Apply molybdenum disulfide oil to the each rotating gear inner surface and C1 bushing whole surface to ensure initial lubrication.

Assemble all parts into their original positions.

**NOTE:**

- Check the gears for freedom of movement or rotation on the shaft.
- Install the washers and snap rings with the chamfered edges facing the thrust load side.
- Do not reuse a worn snap ring which could easily spin in the groove.
- Check that the snap rings are seated in the grooves and align their end gaps with the grooves of the spline.
- Check the special washers are seated in the shaft grooves.

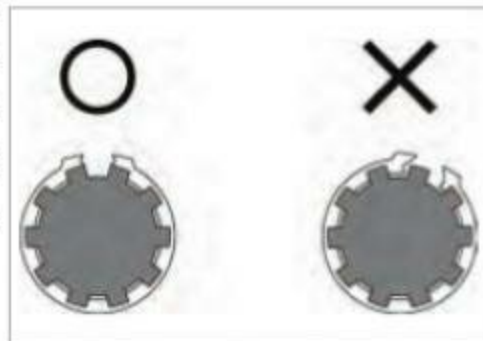

## CRANKCASE/TRANSMISSION/CRANKSHAFT

### MAINSHAFT:

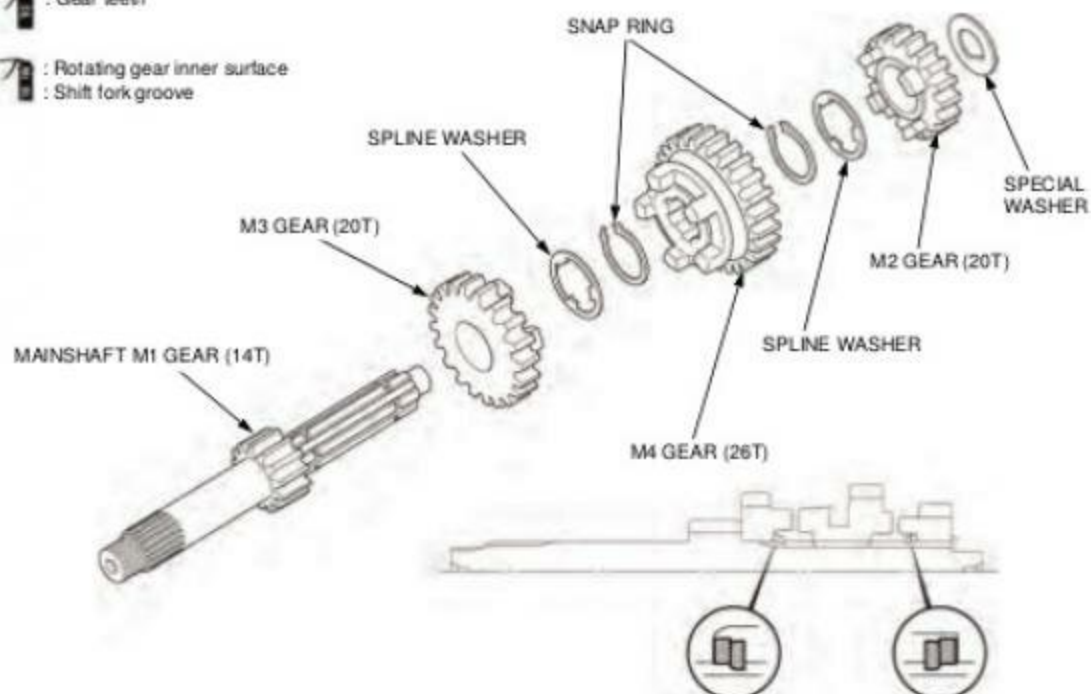

 : Gear teeth

 : Rotating gear inner surface  
 : Shift fork groove



### COUNTERSHAFT:

 : Gear teeth

 : Rotating gear inner surface  
 : Shift fork groove  
 : C 1 bushing whole surface

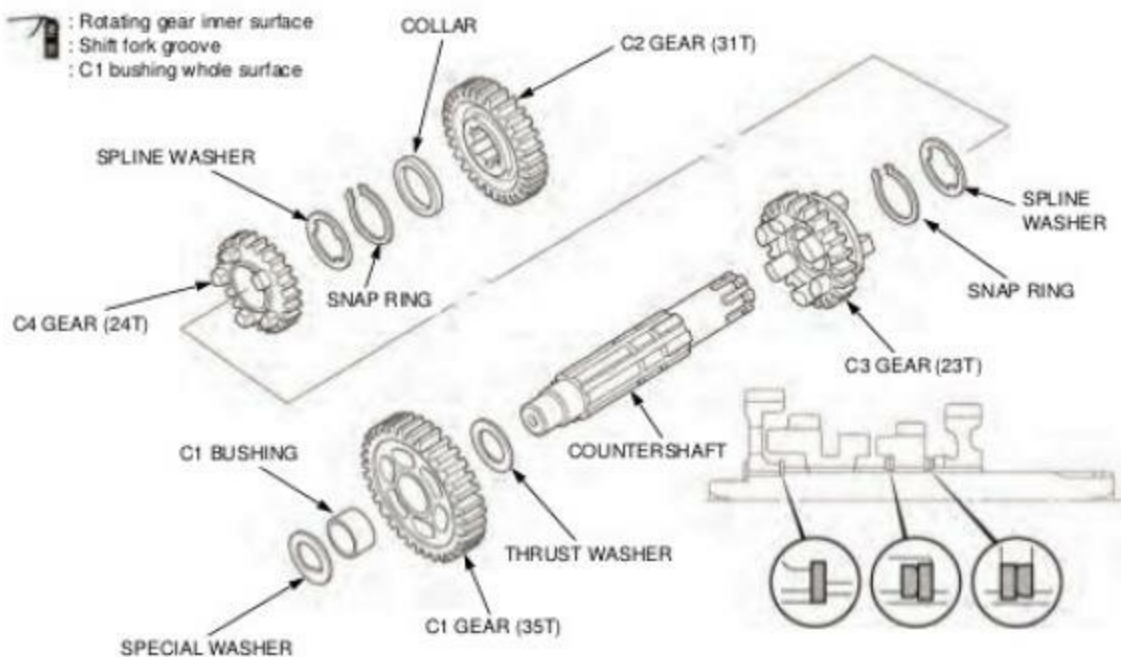

## TRANSMISSION BEARING REPLACEMENT

Remove the crankshaft (page 13-7).

Remove the bolts [1] and mainshaft bearing set plates [2].

Drive out the mainshaft bearing [3] and countershaft bearing [4] from the right crankcase.

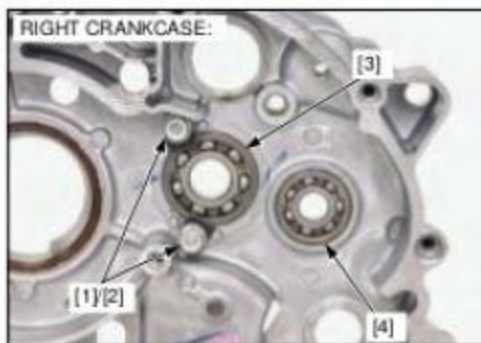

Drive out the countershaft bearing [1] from the left crankcase.



Remove the mainshaft bearing [1] from the left crankcase using the special tools.

### TOOLS:

[2] Bearing remover set, 12 mm 07936-1660101

Bearing remover shaft, 12 mm 07936-1660120

Bearing remover head, 12 mm 07936-1660110

[3] Remover weight 07741-0010201

### U.S.A. TOOLS:

Bearing remover, 12 mm 07936-1660100A

Remover weight 07936-371020A or

07936-3710200

Remover handle 07936-3710100



## CRANKCASE/TRANSMISSION/CRANKSHAFT

Apply engine oil to the new bearing cavities.  
Drive new bearings into the crankcase with their marked side facing up until they are fully seated using the special tools.

### TOOLS:

#### [1] Left crankcase mainshaft bearing:

|                            |               |
|----------------------------|---------------|
| [2] Driver                 | 07749-0010000 |
| [3] Attachment, 28 x 30 mm | 07946-1870100 |
| [4] Pilot, 12 mm           | 07746-0040200 |

#### Left crankcase countershaft bearing:

|                        |               |
|------------------------|---------------|
| Driver                 | 07749-0010000 |
| Attachment, 37 x 40 mm | 07746-0010200 |
| Pilot, 17 mm           | 07746-0040400 |

#### Right crankcase mainshaft bearing:

|                        |               |
|------------------------|---------------|
| Driver                 | 07749-0010000 |
| Attachment, 37 x 40 mm | 07746-0010200 |
| Pilot, 17 mm           | 07746-0040400 |

#### Right crankcase countershaft bearing:

|                        |               |
|------------------------|---------------|
| Driver                 | 07749-0010000 |
| Attachment, 32 x 35 mm | 07746-0010100 |
| Pilot, 12 mm           | 07746-0040200 |

Coating width  
 $6.5 \pm 1.0$  mm  
( $0.26 \pm 0.04$  in)  
from the tip.

Apply locking agent to the threads of the mainshaft bearing set plate bolt [1].

Install the mainshaft bearing set plates [2] and bolts to the right crankcase and tighten the bolts securely.

Install the crankshaft (page 13-10).

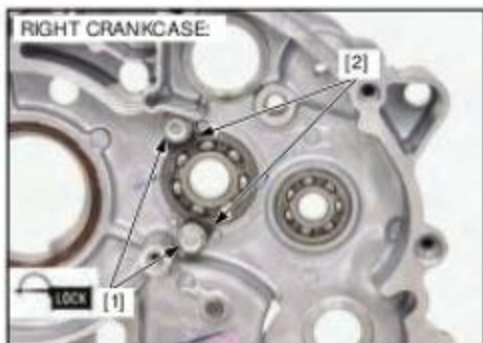

# 14. ENGINE REMOVAL/INSTALLATION

---

|                           |      |                     |      |
|---------------------------|------|---------------------|------|
| SERVICE INFORMATION ..... | 14-2 | ENGINE REMOVAL..... | 14-4 |
| COMPONENT LOCATION .....  | 14-3 |                     |      |

## ENGINE REMOVAL/INSTALLATION

---

### SERVICE INFORMATION

#### GENERAL

- During engine removal and installation, place the motorcycle on a level surface.
- Support the engine using a jack or other adjustable support to ease of engine hanger bolts removal.
- The following components can be serviced with the engine installed in the frame.
  - Alternator (page 12-5)
  - Manual clutch (page 11-7)
  - Gearshift linkage (page 11-10)
  - Cylinder head (page 9-9)
  - Cylinder/piston (page 10-3)
  - Oil pump (page 8-4)
- The following components require engine removal for service.
  - Crankshaft/transmission (page 13-6)
  - Shift forks/shift drum (page 13-10)

#### TORQUE VALUES

##### ENGINE REMOVAL/INSTALLATION

| ITEM                             | Q'TY    | THREAD DIA. (mm) | TORQUE N·m (kgf·m, lbf·ft) | REMARKS      |
|----------------------------------|---------|------------------|----------------------------|--------------|
| Engine hanger nut                | (upper) | 1                | 10                         | 54 (5.5, 40) |
|                                  | (lower) | 1                | 10                         | 54 (5.5, 40) |
|                                  | (front) | 1                | 10                         | 54 (5.5, 40) |
| Drive sprocket fixing plate bolt | 2       | 6                | 12 (1.2, 9)                |              |
| Step holder mounting bolt        | 2       | 8                | 31 (3.2, 23)               |              |

COMPONENT LOCATION

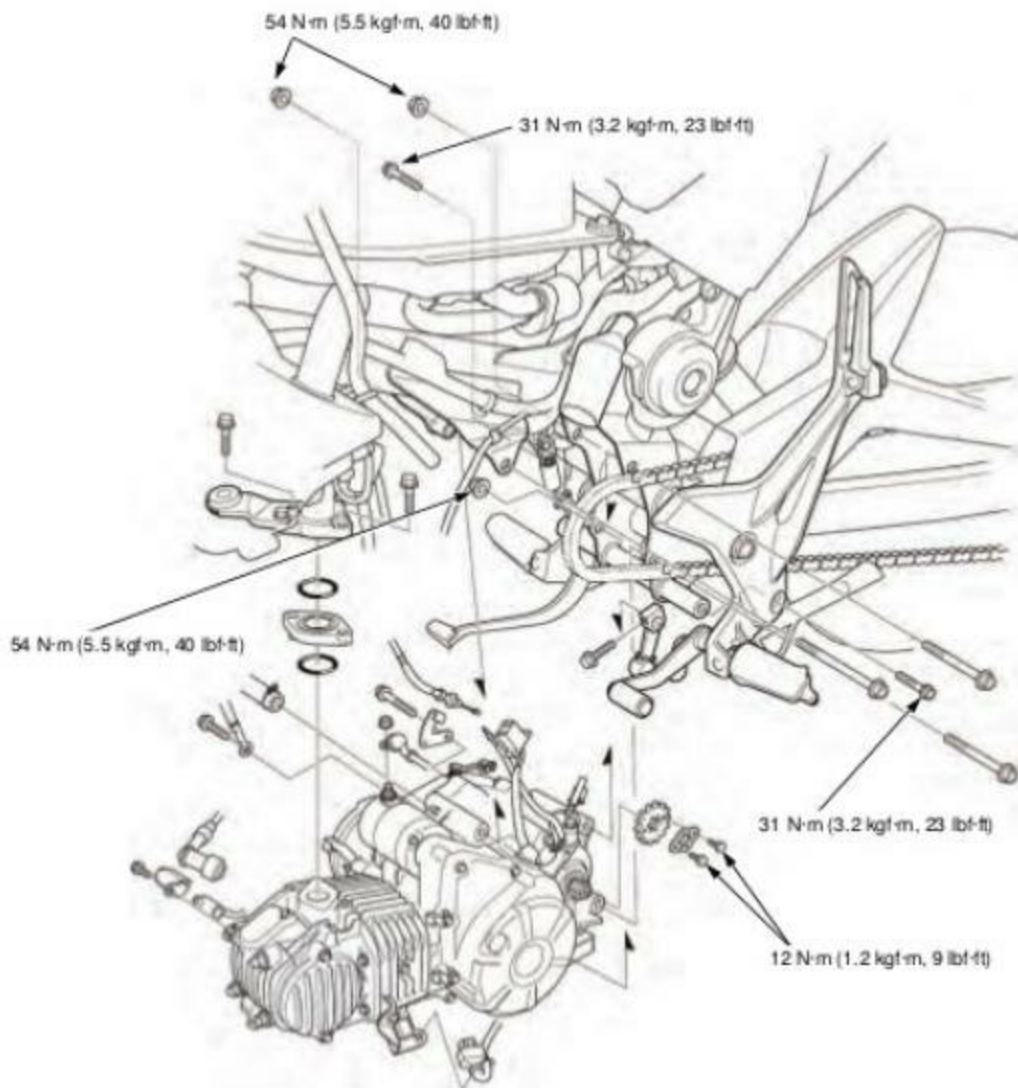

### ENGINE REMOVAL

Support the motorcycle on its sidestand or with a suitable service stand.

Drain the engine oil (page 3-7).

Remove the following:

- Shroud (page 2-4)
- Exhaust pipe (page 2-10)
- Throttle drum cover (page 7-8)
- Clutch cable receiver [1] and cable from the clutch arm.
- Starter motor cable [2]
- Starter motor ground [3]

Disconnect the following:

- Spark plug cap [4]
- O<sub>2</sub> sensor shield, and connector [5] and release the wire from the clamps
- IAT sensor connector [6]



Loosen the lock nuts, drive chain adjusting nuts and axle nut then, push the rear wheel forward.

Remove the following:

- Rear crankcase cover, disconnecting the wires from the wire damp.
- Sprocket [1]
- Breather hose [2]
- Pull back the rubber boot of the gearshift shaft/gearshift arm, remove the split pin, and disconnect the shaft from the arm, then remove the gearshift arm [3] from the gearshift spindle
- Intake pipe mounting bolts [4]

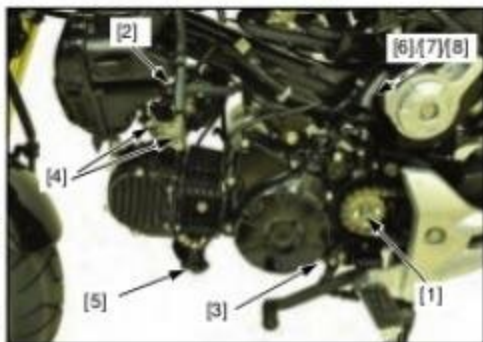

Disconnect the following and remove all wires from their clamps:

- EOT sensor connector [5] and release the wire from the clamps
- Alternator connector [6]
- VS sensor connector [7]
- Neutral switch connector [8]

Remove the swingarm pivot nut [1], right step holder mounting bolt [2] and right step holder [3].

Install the swingarm pivot nut [1] to the swingarm pivot shaft temporarily.

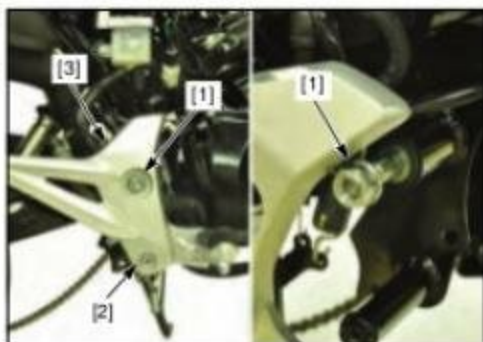

Remove the left step holder mounting bolt [1].

Pull the left step holder out by 200 mm, remove the circlip and gearshift lever, and rotate the step holder to allow removal of the rear lower engine hanger nut.

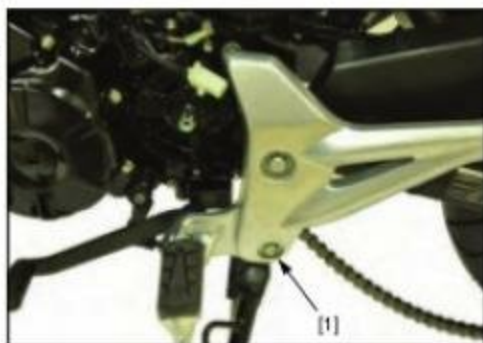

Support the engine using a jack or other adjustable support.

Remove the front engine hanger nut [1], rear upper engine hanger nut [2] and rear lower engine hanger nut [3].

Remove the engine hanger bolts [4] and engine from the frame.

Installation is in the reverse order of removal.

**TORQUE:**

|                                   |                                  |
|-----------------------------------|----------------------------------|
| Rear upper engine hanger nut:     | 54 N·m (5.5 kgf·m,<br>40 lbf·ft) |
| Rear lower engine hanger nut:     | 54 N·m (5.5 kgf·m,<br>40 lbf·ft) |
| Front engine hanger nut:          | 54 N·m (5.5 kgf·m,<br>40 lbf·ft) |
| Drive sprocket fixing plate bolt: | 12 N·m (1.2 kgf·m,<br>9 lbf·ft)  |
| Step holder mounting bolt:        | 31 N·m (3.2 kgf·m,<br>23 lbf·ft) |
| Swingarm pivot nut:               | 54 N·m (5.5 kgf·m,<br>40 lbf·ft) |

Fill the recommended engine oil up to the proper level (page 3-7).

Adjust the drive chain slack (page 3-9).

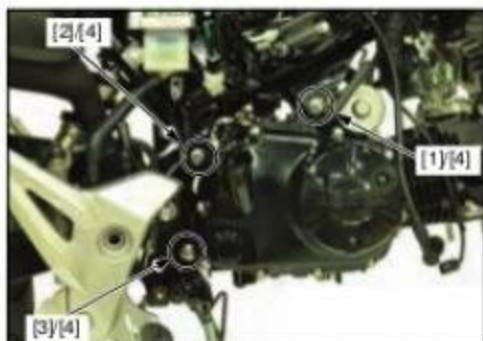

---

**MEMO**

---

# 15. FRONT WHEEL/SUSPENSION/STEERING

---

|                           |      |                     |       |
|---------------------------|------|---------------------|-------|
| SERVICE INFORMATION ..... | 15-2 | FORK.....           | 15-8  |
| TROUBLESHOOTING.....      | 15-4 | HANDLEBAR .....     | 15-16 |
| COMPONENT LOCATION .....  | 15-5 | STEERING STEM ..... | 15-20 |
| FRONT WHEEL.....          | 15-6 |                     |       |

## FRONT WHEEL/SUSPENSION/STEERING

### SERVICE INFORMATION

#### GENERAL

#### **▲ WARNING**

Frequent inhalation of brake pad dust, regardless of material composition could be hazardous to your health.

- Avoid breathing dust particles.
- Never use an air hose or brush to clean brake assemblies. Use an OSHA-approved vacuum cleaner.

- This section covers the front wheel, fork, handlebar and steering stem.
- When servicing the front wheel, fork or steering stem, support the motorcycle using a jack or other support.
- A contaminated brake disc or pad reduces stopping power. Discard contaminated pads and clean a contaminated disc with a high quality brake degreasing agent.
- After the front wheel installation, check the brake operation by applying the brake lever.

#### SPECIFICATIONS

Unit: mm (in)

| ITEM                     |                        | STANDARD                                    | SERVICE LIMIT |
|--------------------------|------------------------|---|---------------|
| Minimum tire tread depth |                        | -   | To indicator  |
| Cold tire pressure       | Driver only            | 200 kPa (2.00 kgf/cm <sup>2</sup> , 29 psi) | -             |
|                          | Driver and passenger   | 200 kPa (2.00 kgf/cm <sup>2</sup> , 29 psi) | -             |
| Axle runout              |                        | -   | 0.2 (0.01)    |
| Wheel rim runout         | Radial                 | -   | 2.0 (0.08)    |
|                          | Axial                  | -   | 2.0 (0.08)    |
| Fork                     | Pipe runout            | -   | 0.20 (0.010)  |
|                          | Recommended fork fluid | Pro Honda Suspension Fluid SS-8 (10W)       | -             |
|                          | Fluid level            | 75 (2.95)                                   | -             |
|                          | Fluid capacity         | 221.0 ± 1.5 cm <sup>3</sup>                 | -             |

#### TORQUE VALUES

##### FRONT WHEEL/SUSPENSION/STEERING

| ITEM                          | Q'TY | THREAD<br>DIA. (mm) | TORQUE<br>N·m (kgf·m, lbf·ft) | REMARKS                             |
|-------------------------------|------|---------------------|-------------------------------|-------------------------------------|
| Front axle nut                | 1    | 12                  | 54 (5.5, 40)                  | U-nut                               |
| Front brake disc bolt         | 4    | 8                   | 42 (4.3, 31)                  | ALOC bolt; replace with a new one.  |
| Fork bolt                     | 2    | 36                  | 30 (3.1, 22)                  |                                     |
| Fork socket bolt              | 2    | 8                   | 20 (2.0, 15)                  | Apply locking agent to the threads. |
| Steering stem nut             | 1    | 24                  | 88 (9.0, 65)                  | See page 15-22                      |
| Steering stem adjusting nut   | 1    | 26                  | 1.5 (0.2, 1.1)                | See page 15-22                      |
| Top bridge pinch bolt         | 2    | 8                   | 27 (2.8, 20)                  |                                     |
| Bottom bridge pinch bolt      | 4    | 8                   | 27 (2.8, 20)                  |                                     |
| Handlebar holder bolt         | 2    | 8                   | 27 (2.8, 20)                  |                                     |
| Handlebar holder mounting nut | 2    | 8                   | 27 (2.8, 20)                  |                                     |
| Handlebar weight screw        | 2    | 6                   | 9.0 (0.9, 6.6)                | ALOC screw; replace with a new one. |
| Left handlebar switch screw   | 2    | 5                   | 2.5 (0.3, 1.8)                |                                     |
| Right handlebar switch screw  | 2    | 5                   | 2.5 (0.3, 1.8)                |                                     |
| Clutch lever pivot bolt       | 1    | 6                   | 1.0 (0.1, 0.7)                |                                     |
| Clutch lever pivot nut        | 1    | 6                   | 5.9 (0.6, 4.4)                |                                     |

TOOLS

|   |  |   |
|---|--|---|
| <p>Fork Seal Driver 31 mm<br/>070MD-K200100</p>  <p>or 070MD-K20A100 (U.S.A. only)</p> | <p>Attachment, 37 x 40 mm<br/>07746-0010200</p>                     | <p>Fork Seal Driver Attachment 27.2 mm<br/>07747-0010300</p>                             |
| <p>Pilot 12 mm<br/>07746-0040200</p>   | <p>Bearing Remover Shaft 9 x 200L<br/>07746-0050100</p>             | <p>Remover Head 12 mm<br/>07746-0050300</p>    |
| <p>Driver<br/>07749-0010000</p>   | <p>Locknut Wrench 5.7 x 50<br/>07916-3710101</p>                   | <p>Shaft Installer<br/>07WMF-GCM0100</p>  <p>or 07931-ME9010 (U.S.A. only)</p>           |
| <p>Head Base<br/>07WMF-GCM0200</p>  <p>07WMF-GCMA200 (U.S.A. only)</p>               | <p>Base<br/>07WMF-GCM0300</p>  <p>07WMF-GCMA300 (U.S.A. only)</p> | <p>Driver Attachment 48.5 mm<br/>07WMF-GCM0400</p>  <p>07WMF-GCMA400 (U.S.A. only)</p> |

Remover 35mm  
07WMF-GCM0600



07WMF-GCMA600 (U.S.A. only)

## TROUBLESHOOTING

### Hard steering

- Insufficient tire pressure
- Faulty tire
- Steering stem lock nut too tight
- Faulty steering head bearing
- Faulty steering head bearing race
- Bent steering stem

### Steers to one side or does not track straight

- Bent front axle
- Wheel installed incorrectly
- Worn or damaged front wheel bearings
- Bent fork
- Worn or damaged engine mounting bushings
- Bent frame
- Faulty steering head bearing

### Front wheel wobbles

- Loose front axle fasteners
- Bent rim
- Worn or damaged front wheel bearings

### Front wheel turns hard

- Front brake drag
- Bent front axle
- Faulty front wheel bearings

### Soft suspension

- Low tire pressure
- Deteriorated fork fluid
- Incorrect fork fluid weight
- Insufficient fluid in fork
- Weak fork spring

### Hard suspension

- High tire pressure
- Too much fluid in fork
- Incorrect fork fluid weight
- Bent fork pipes
- Clogged fork fluid passage

### Suspension noisy

- Bent fork slider
- Insufficient fluid in fork
- Loose fork fasteners

## COMPONENT LOCATION

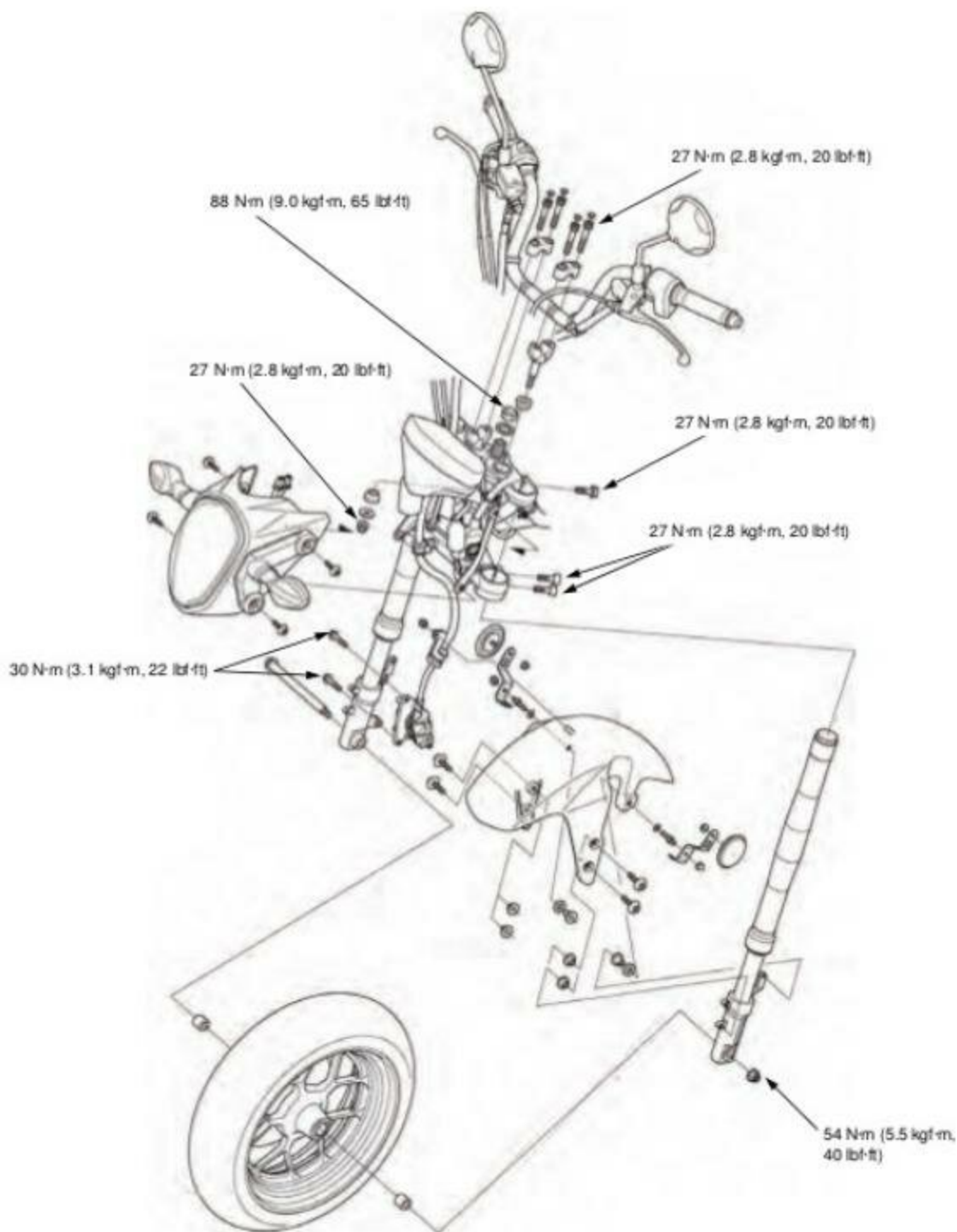

### FRONT WHEEL

#### NOTE:

Support the motorcycle securely using a safety stand or hoist and raise the front wheel off the ground.

#### REMOVAL

Loosen the front axle nut [1].

Remove the front axle nut.

Remove the front axle out and remove the front wheel.

Remove the side collar from the wheel.

*Do not operate the brake lever after removing the front wheel.*



#### INSPECTION

Inspect the following parts for damage, abnormal wear, deformation, looseness, smoothly operation or bend.

- Front axle
- Wheel rim
- Wheel bearing

#### NOTE:

Replace the bearings in pairs.

#### TIRE

#### NOTICE

*Wheel balance directly affects stability, handling and overall safety of the motorcycle. Always check balance when the tire has been removed from the rim.*

Note the rotating direction mark [1] on the tire.

When installing the tires align the balance mark [2] of the tire and valve [3] of the rim within 50 mm.

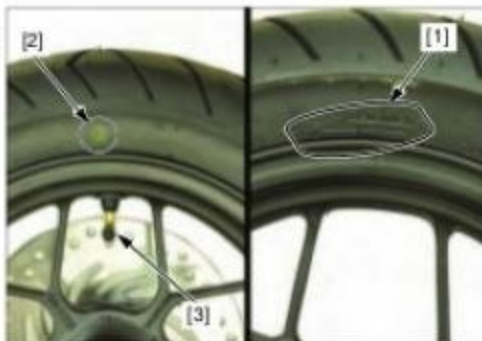

## DISASSEMBLY/ASSEMBLY

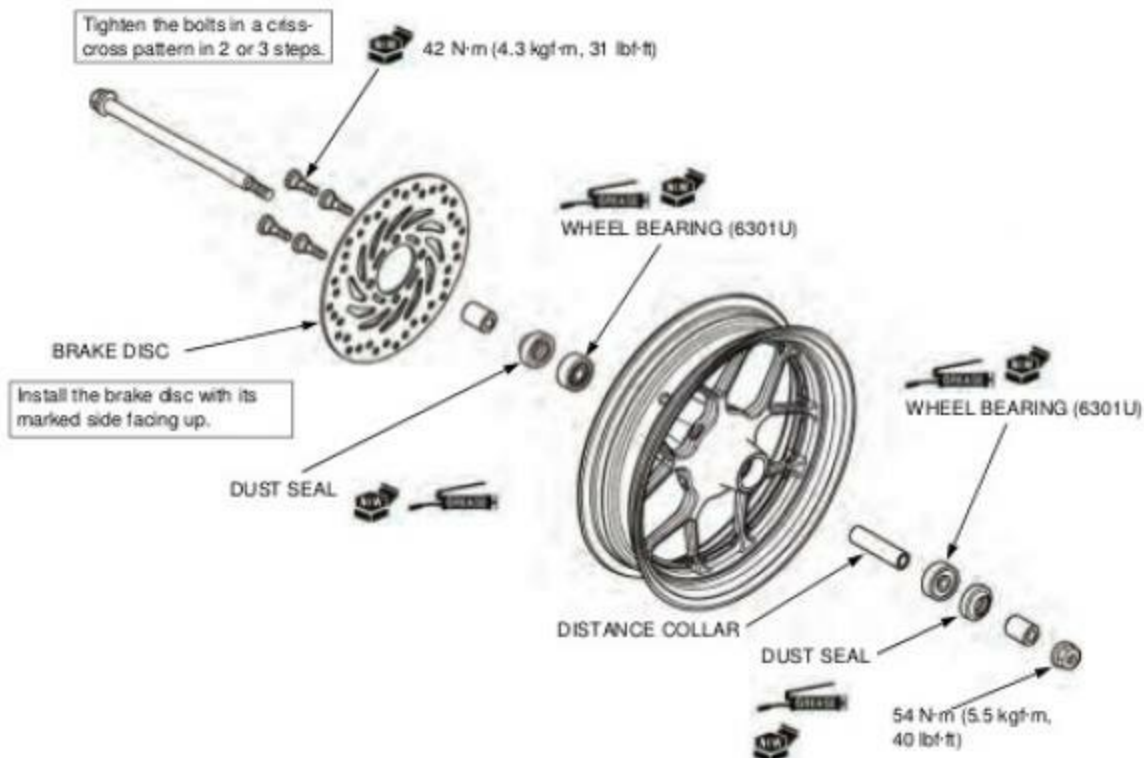

## BEARING REPLACEMENT

Install the bearing remover head into the bearing.  
From the opposite side, install the bearing remover shaft and drive the bearing out of the wheel hub.  
Remove the distance collar and drive out the other bearing.

## TOOLS:

Remover head, 12 mm [1] 07746-0050300  
Bearing remover shaft [2] 07746-0050100

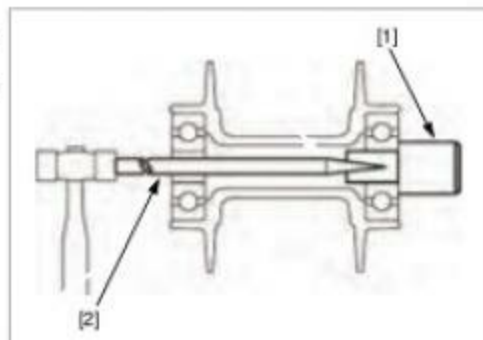

Pack all bearing cavities with grease.

Drive in a new left bearing [1] squarely with its sealed side facing up until it is fully seated.

## TOOLS:

Driver [2] 07749-0010000  
Attachment, 37 x 40 mm [3] 07746-0010200  
Pilot, 12 mm [4] 07746-0040200



## FRONT WHEEL/SUSPENSION/STEERING

### WHEEL CENTER ADJUSTMENT

Apply thin coat of grease to the distance collar [1] and install it.

Drive in a new right bearing [2] squarely with its sealed side facing up until its inner race is seated on the distance collar.

#### TOOLS:

|                        |                |
|------------------------|----------------|
| Driver                 | 07749-001 0000 |
| Attachment, 37 x 40 mm | 07746-001 0200 |
| Pilot, 12 mm           | 07746-004 0200 |

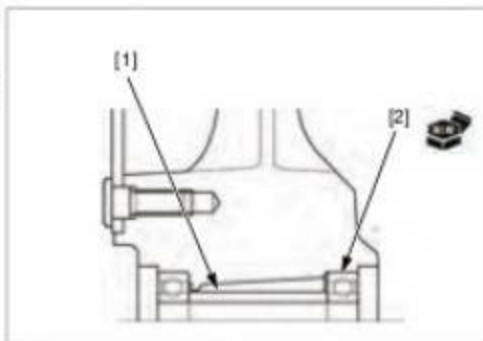

### INSTALLATION

Install the axle nut [1] and tighten it to the specified torque.

**TORQUE:** 54 N·m (5.5 kgf·m, 40 lbf·ft)



## FORK

### REMOVAL

Remove the following:

- Front fender (page 2-3)
- Front wheel (page 15-6)

*Support the front brake caliper with a piece of wire so that*

*it does not hang from the front brake hose.*

*Do not twist the brake hose.*

Remove the bolt [1] and front brake caliper from the left fork leg.



Loosen the fork top bridge pinch bolt [1].

*In case of front fork disassembly only:*

Loosen the fork bolt.

Loosen the bottom fork pinch bolt [2] and remove the fork leg from the steering stem.



**DISASSEMBLY**

Remove the fork cap [1].



Install the special tool as shown.

**NOTE:**

To protect the dust seal from damage keep the special tool in the shown position until outer tube [1] is removed.

**TOOL:**

Oil seal driver, 31 mm [2]

070MD-K200100 or  
070MD-K20A100  
(U.S.A. only)



Completely loosen the fork bolt [1].

Pour out the fork fluid by pumping the fork pipe several times.

**NOTE:**

Do not let the outer tube fall down as it can damage the dust seal.

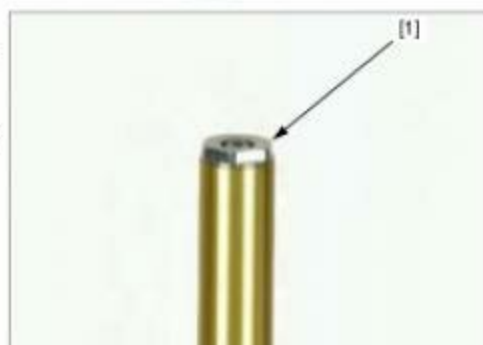

Wrap the shop towel [1] around piston rod and hold it with a pliers [2] as shown

Remove the bolt [3] and sealing washer [4].

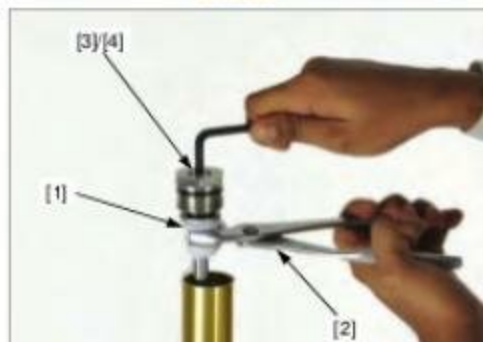

## FRONT WHEEL/SUSPENSION/STEERING

Remove the fork bolt [1] and o-ring [2].

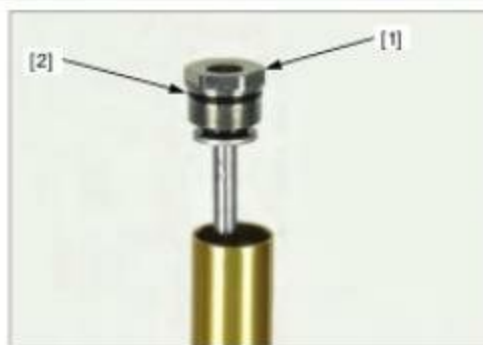

Remove the stopper rubber [1] and seat [2].

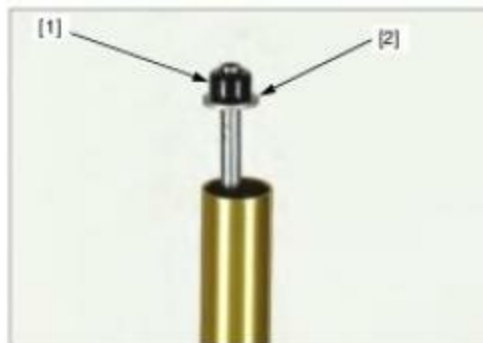

Remove the stopper ring [1].

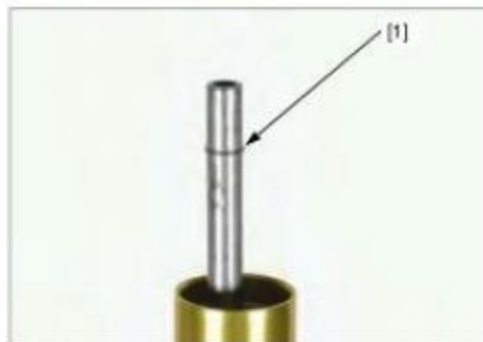

*Be careful not to scratch the damper assembly sliding surface.* Remove the dust seal [1] using the screw driver.



Remove the oil seal stopper ring [1].



Using quick successive motions, pull the outer tube [1] out of the damper assembly.



*Do not damage the side bushing and piston ring, especially the sliding surface. To prevent loss of tension, do not open the slid bushing and piston ring more than necessary.*

Remove the piston ring [1] and slide bushing [2] by spreading their ends.

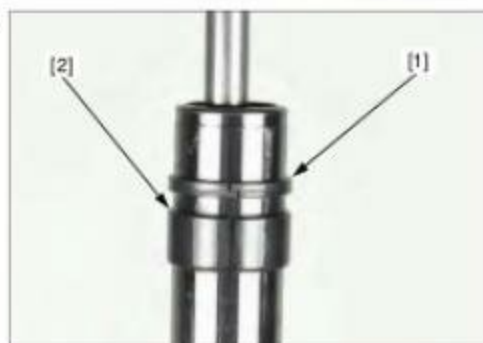

Remove the guide bushing [1], back up ring [2] and oil seal [3].



## FRONT WHEEL/SUSPENSION/STEERING

### INSPECTION

Inspect the following parts for damage, abnormal wear, bend, deformation and scoring.

- Fork pipe
- Outer tube
- Slide bushing
- Guide bushing
- Back up ring

### ASSEMBLY

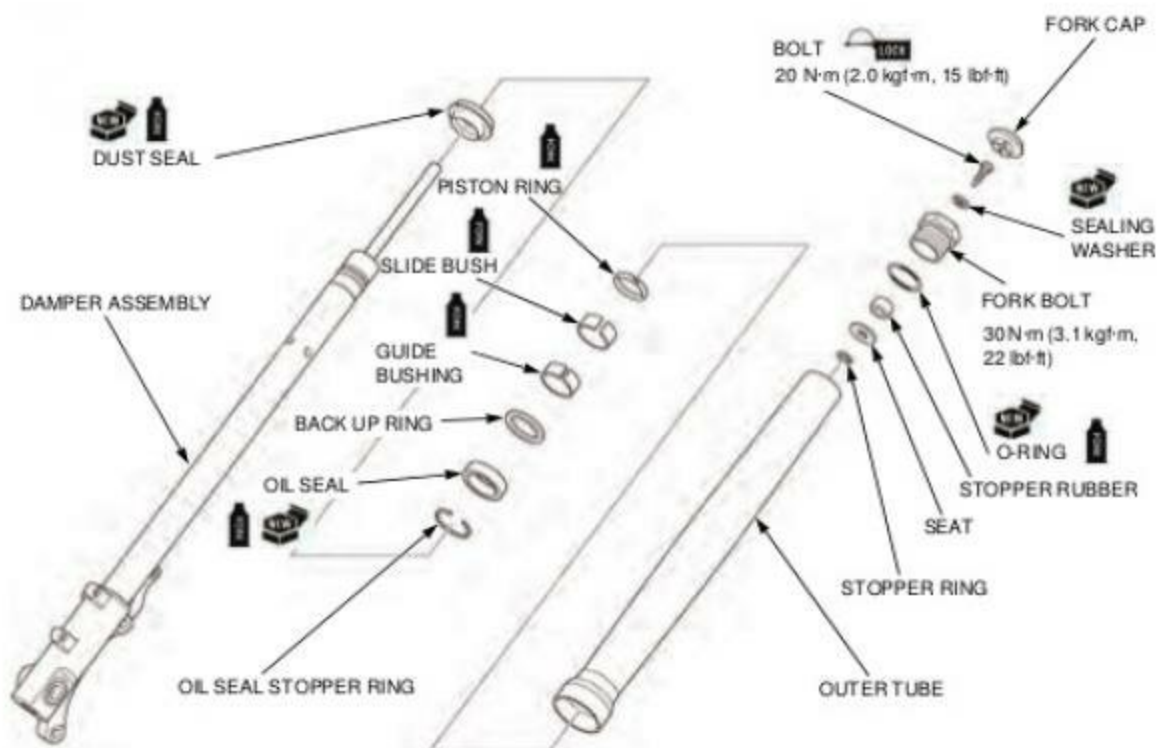

Before assembly, wash all parts with high flash point or non-flammable solvent and wipe them dry.

Install the guide bushing [1], back up ring [2] and new oil seal [3].



Install the piston ring [1] and slide bushing [2] by spreading their ends.



Install the outer tube [1].



Drive the new oil seal [1] into the outer tube [2] by using the special tool.

**TOOL:**

Oil seal driver, 31 mm [3]

070MD-K20 0100 or  
070MD-K20 A100  
(U.S.A. only)



Install the oil seal stopper ring [1].

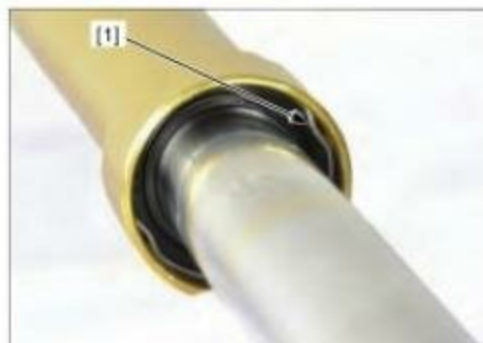

## FRONT WHEEL/SUSPENSION/STEERING

Install the dust seal [1].



Pour the specified amount of recommended fork fluid into the fork pipe.

**FORK FLUID CAPACITY:**  
**221 ± 1.5 cm<sup>3</sup>**

Pump the fork pipe several times to remove trapped air from the lower portion of the fork pipe.

*Be sure the oil level is same in the both forks.*

Compress the fork leg fully and measure the fluid level from the top of the fork pipe.

**FORK FLUID LEVEL: 75 mm (2.95 in)**



Install the stopper ring [1].

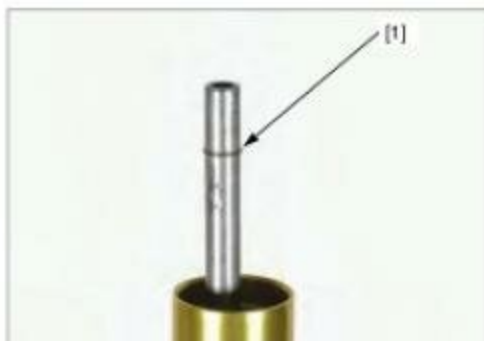

Install the seat [1] and stopper rubber [2].

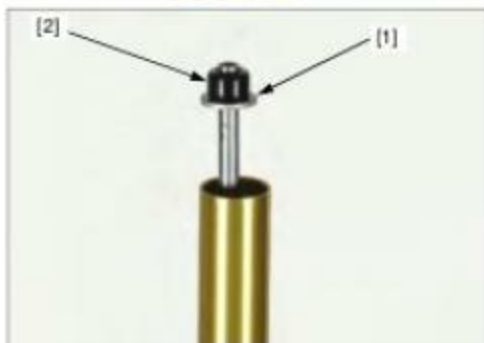

Install the fork bolt [1] and new o-ring [2].

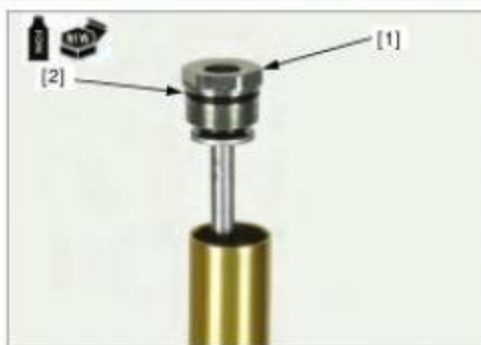

Wrap the shop towel [1] around piston rod and hold it with a pliers [2] as shown

Apply a locking agent to the fork socket bolt [3] threads and install with a new sealing washer [4].

Tighten the fork socket bolt.

**TORQUE: 20 N·m (2.0 kgf·m, 15 lbf·ft)**

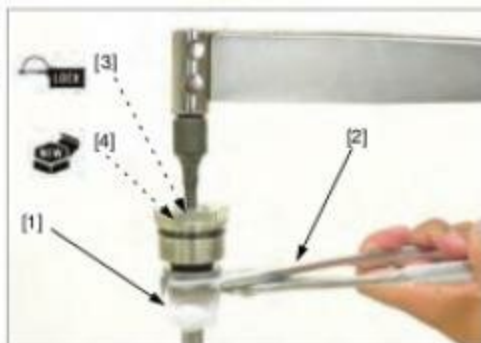

Tighten the fork bolt loosely and install the fork cap [1].



## INSTALLATION

Install the fork leg into the bottom and top bridge.

Align the top of the outer tube with the upper surface of the top bridge.

Tighten the bottom bridge pinch bolts [1] to the specified torque.

**TORQUE: 27 N·m (2.8 kgf·m, 20 lbf·ft)**

Tighten the top bridge pinch bolts [2] loosely.

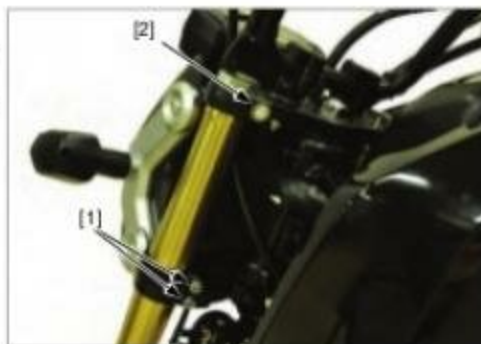

## FRONT WHEEL/SUSPENSION/STEERING

Tighten the fork bolt [1] to the specified torque.

**TORQUE:** 30 N·m (3.1 kgf·m, 22 lbf·ft)



Tighten the top bridge pinch bolts [1] to the specified torque.

**TORQUE:** 27 N·m (2.8 kgf·m, 20 lbf·ft)



Install the front brake caliper and new mounting bolts [1] to the left fork leg, then tighten them to the specified torque.

**TORQUE:** 30 N·m (3.1 kgf·m, 22 lbf·ft)

Install the following:

- Front wheel (page 15-8)
- Front fender (page 2-3)



## HANDLEBAR

### REMOVAL

*The rearview mirror lock nuts has left hand threads.*

Remove the rearview mirrors and wire bands.

Remove the screws [1] and left handlebar switch [2].

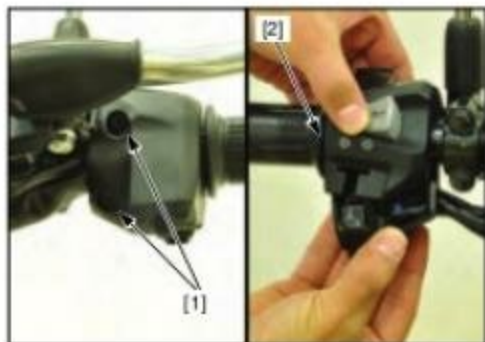

Slide the clutch switch cover off.

Disconnect the clutch switch connector.

Remove the bolts [1], holder and clutch lever bracket [2].

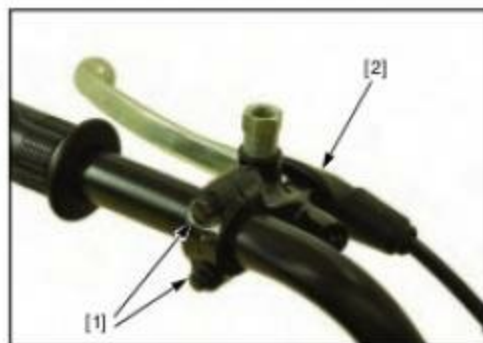

Disconnect the front brake switch connector [1].

Remove the bolts and front master cylinder holder [2].

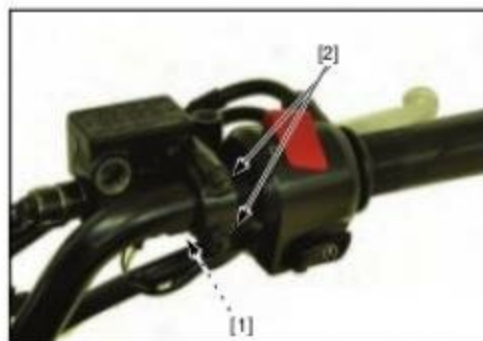

Remove the four caps, four socket bolts [1], upper holders [2] and handlebar.

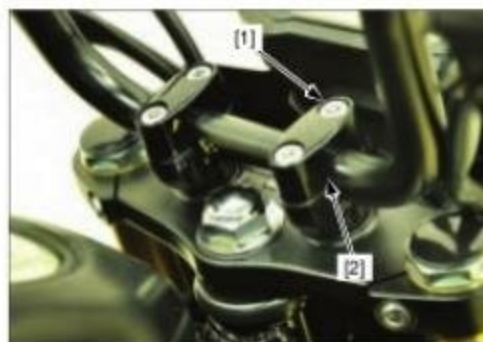

Remove the right handlebar switch and throttle pipe [1] from the handlebar.

Disconnect the throttle cable [2] from the throttle pipe.

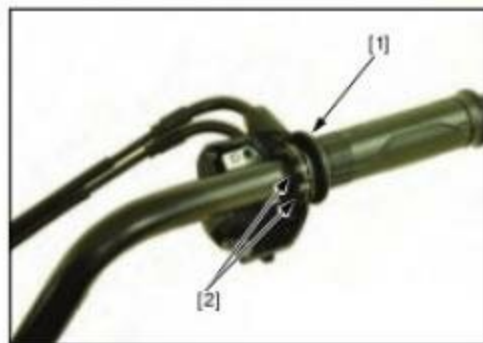

## FRONT WHEEL/SUSPENSION/STEERING

### INSTALLATION

If the left handle grip [1] were removed, apply Honda Bond A or equivalent to the inside of the grip and to the clean surfaces of the left handlebar [2].

Wait 3 – 5 minutes and install the grip.

Rotate the grip for even application of the adhesive.

*Allow the adhesive to dry for 1 hour before using.*

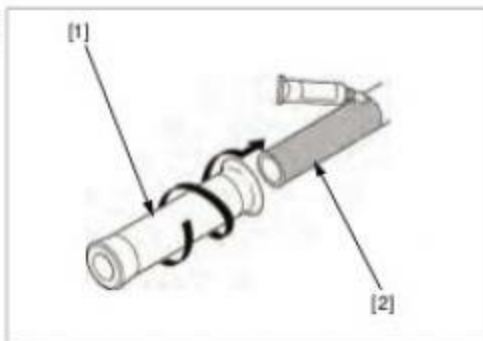

Apply grease to the throttle cable ends [1] and cable guide grooves of the throttle pipe [2].

Connect the throttle cable ends to the throttle pipe.

Install the right handlebar switch and throttle pipe onto the handlebar.

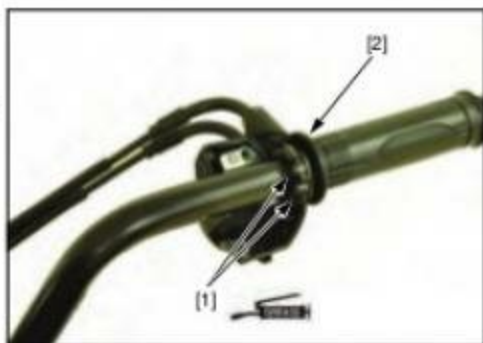

Install the handlebar onto the lower holders by aligning the punch mark on the handlebar with the top edge of the lower holder.

Install the upper holders [1] with the punch marks facing forward.

Tighten the forward bolts first, then tighten the rear bolts to the specified torque.

**TORQUE: 27 N·m (2.8 kgf·m, 20 lbf·ft)**

*Align the punch mark [2] on the handlebar with the mating surface of the upper and lower holders.*

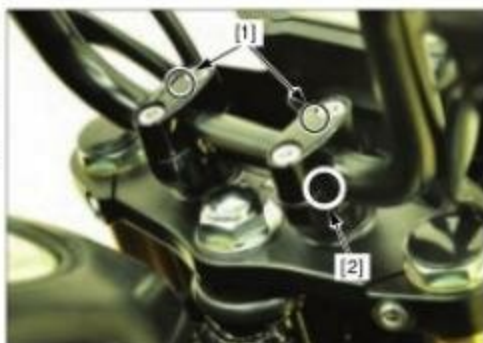

Install the right handlebar switch [1] aligning its locating pin with the hole on the handlebar.

Install the right handlebar switch screws [2].

Tighten the forward screw first, then the rear screw.



Install the front master cylinder, holder ("UP" mark facing up) and bolts [1].

Align the end of the master cylinder with the punch mark on the handlebar and tighten the upper bolt first, then the lower bolt to the specified torque.

**TORQUE: 10 N·m (1.0 kgf·m, 7 lbf·ft)**

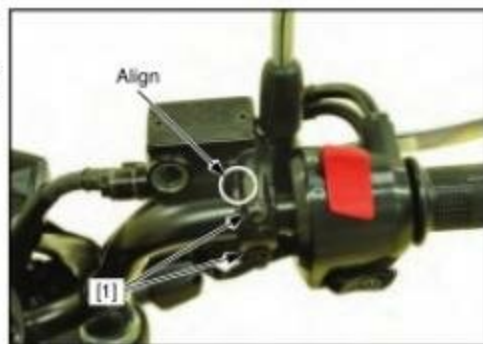

Align the end of the clutch lever bracket with the punch mark on the handlebar and tighten the upper bolt [2] first, then the lower bolt to the specified torque.

**TORQUE: 10 N·m (1.0 kgf·m, 7 lbf·ft)**

Connect the clutch switch connector.

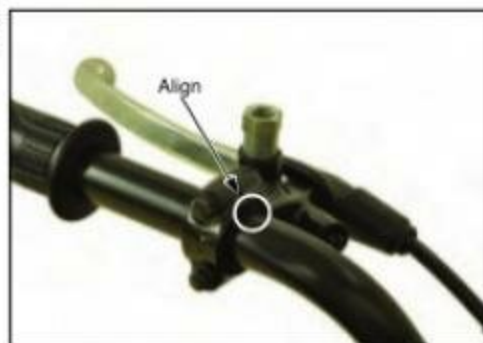

Install the left handlebar switch [1] aligning its locating pin with the hole on the handlebar.

Install the left handlebar switch screws [2]. Tighten the forward screw first, then the rear screw.

Install the four caps, wire bands and mirrors.

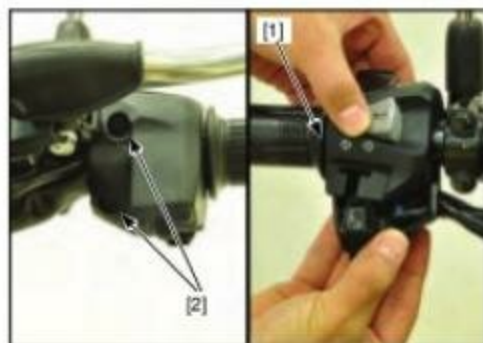

### STEERING STEM

#### REMOVAL

Remove the headlight assembly (page 2-7).

Disconnect the following:

- Right handlebar switch connector [1]
- Left handlebar switch connector [2]
- Combination meter connector [3]
- Ignition switch connector [4]
- Horn connector [5]

Remove the horn harness clip from the stay [6]



Remove the handlebar (page 15-16).

Remove the top bridge pinch bolt [1], steering stem nut [2], washer [3] and top bridge.

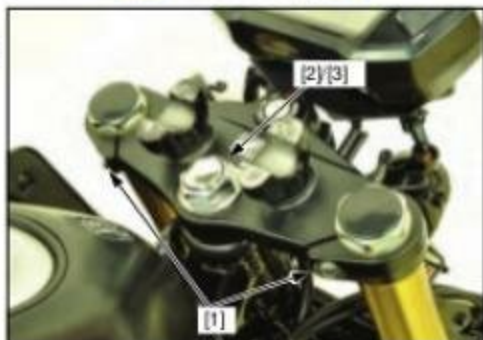

Remove the fork [1] (page 15-8).

Remove the front brake hose clamp from the steering stem.

Remove the headlight/meter assembly bracket from the steering stem.

Loosen the steering stem adjusting nut using a special tool.

#### TOOL:

**Steering stem socket [2]      07916-3710101**

Hold the steering stem and remove the steering stem adjusting nut.

Remove the following:

- Upper inner race
- Upper bearing
- Steering stem
- Lower bearing



**BEARING REPLACEMENT****OUTER RACE**

- Always replace the steel bearings and races as a set.

Replace the outer races using the special tools:

**TOOL:**

|   |               |
|---|---------------|
| [1] Shaft installer                         | 07WMF-GCM0100 |
| [2] Head base                               | 07WMF-GCM0200 |
| [3] Base                                    | 07WMF-GCM0300 |
| [4] Driver attachment 48.5 mm<br>(2 pieces) | 07WMF-GCM0400 |
| [5] Remover 35 mm                           | 07WMF-GCM0600 |

**U.S.A. TOOLS:**

|                           |               |
|---------------------------|---------------|
| Installer shaft           | 07WMF-KZ30200 |
| Head base                 | 07WMF-GCMA200 |
| Base                      | 07WMF-GCMA300 |
| Driver attachment 48.5 mm | 07WMF-GCMA400 |
| Remover 35 mm             | 07WMF-GCMA600 |

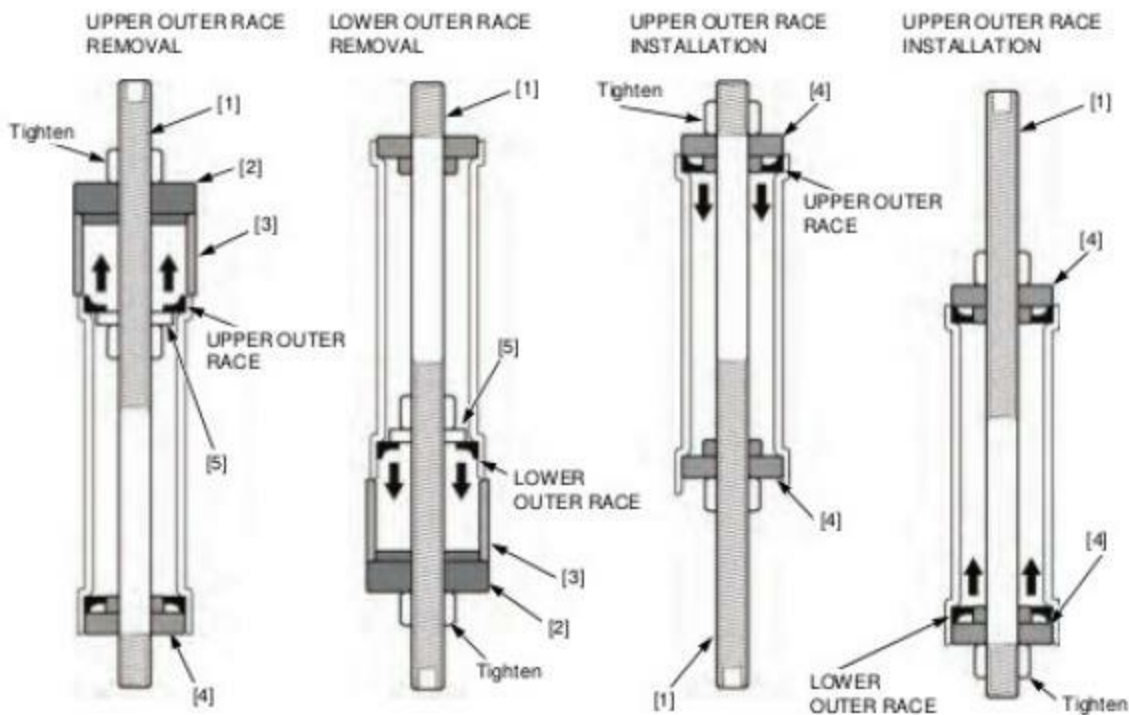

## FRONT WHEEL/SUSPENSION/STEERING

### LOWER INNER RACE

**Removal:** Temporarily install the steering stem nut onto the stem to prevent the threads from being damaged when removing the lower inner race from the steering stem.

Remove the dust seal and washer.

Remove the lower bearing inner race with a chisel or equivalent tool being careful not to damage the stem.

**Installation:** Install the washer and new dust seal to the steering stem.

Install a new lower bearing inner race [1] using the following tool and hydraulic press.



#### TOOL:

**Steering stem driver attachment 07946-KA6000A**

### INSTALLATION

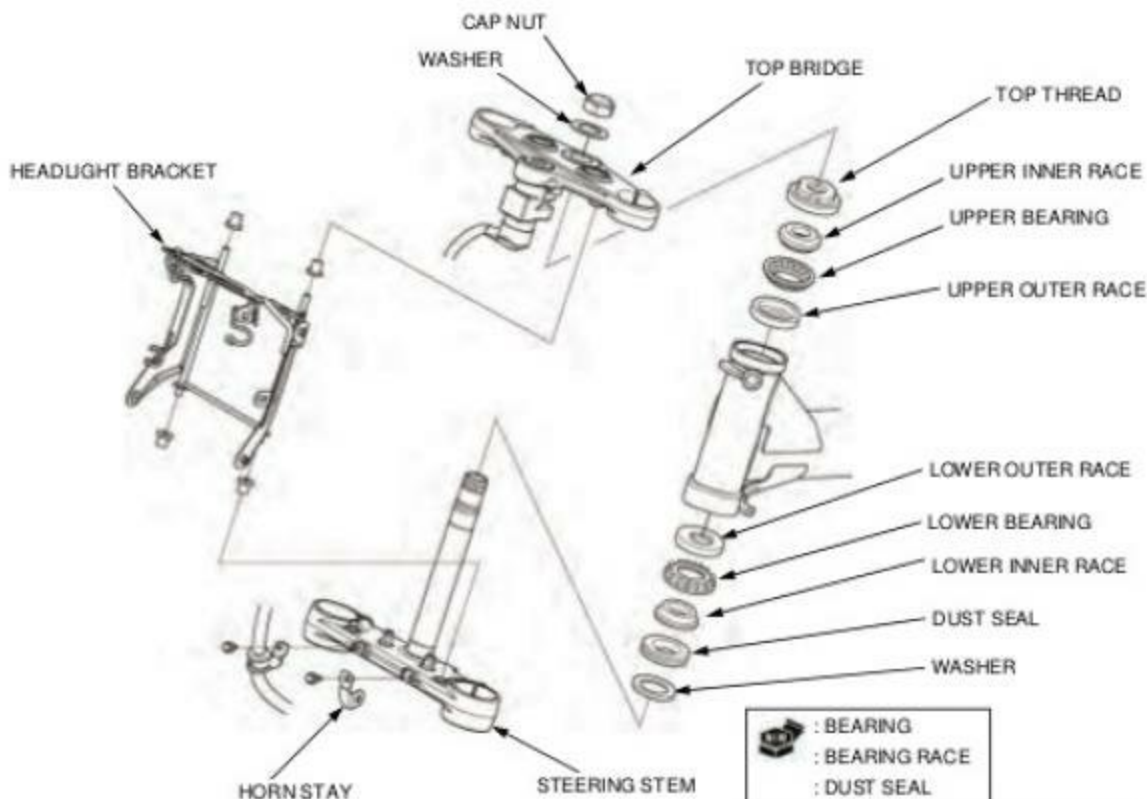
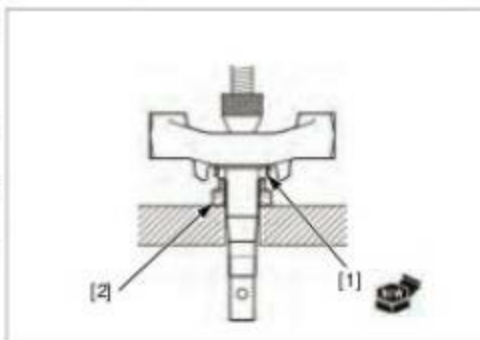
- Always replace the steel balls and races as a set.



 : BEARING  
 : BEARING RACE  
 : DUST SEAL

 : BEARING  
 : INNER RACE  
 : OUTER RACE  
 : DUST SEAL

grease with extreme pressure agent  
(recommended: EXCELITE EP2  
manufactured by KYODO YUSHI, Japan or  
Shell ALVANIA EP2 or equivalent)

Install the top thread.

Hold the steering stem and tighten the stem top thread [1] to the initial torque using the special tool.

**TOOL:**

**Steering stem socket [2] 07916-3710101**

**TORQUE: 27 N·m (2.8 kgf·m, 20 lbf·ft)**



Turn the steering stem lock-to-lock several times to seat the bearing.



Loosen the top thread [1].

Hold the steering stem and tighten the stem top thread [1] to the initial torque using the special tool.

**TOOL:**

**Steering stem socket 07916-3710101**

**TORQUE: 1.5 N·m (0.2 kgf·m, 1.1 lbf·ft)**



Install the fork (page 15-15).

Install the top bridge, washer and tighten the stem nut [1] to the specified torque.

**TORQUE: 88 N·m (9.0 kgf·m, 65 lbf·ft)**

Make sure the steering stem moves smoothly without play or binding.

Install the handlebar (page 15-16).

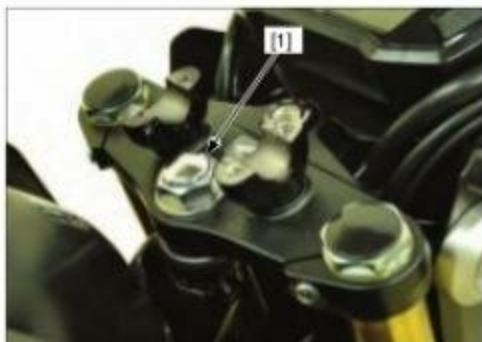

## FRONT WHEEL/SUSPENSION/STEERING

---

Connect the following:

- Right handlebar switch connector [1]
- Left handlebar switch connector [2]
- Combination meter connector [3]
- Ignition switch connector [4]
- Horn connector [5]
- horn harness clip to the stay [6]
- Horn

Install the headlight assembly (page 2-7).



## 16. REAR WHEEL/SUSPENSION

---

|                           |      |                      |      |
|---------------------------|------|----------------------|------|
| SERVICE INFORMATION ..... | 16-2 | REAR WHEEL.....      | 16-5 |
| TROUBLESHOOTING.....      | 16-3 | SHOCK ABSORBER ..... | 16-7 |
| COMPONENT LOCATION .....  | 16-4 | SWINGARM .....       | 16-8 |

## REAR WHEEL/SUSPENSION

### SERVICE INFORMATION

#### GENERAL

- When servicing the rear wheel and suspension, support the motorcycle using a safety stand or hoist.
- A contaminated brake disc or pad reduces stopping power. Discard contaminated pads and clean a contaminated disc with a high quality brake degreasing agent.
- After the rear wheel installation, check the brake operation by applying the brake pedal.
- Use only tires marked "TUBELESS" and tubeless valves on rim marked "TUBELESS TIRE APPLICABLE".
- Use genuine Honda replacement bolts and nuts for all suspension pivot and mounting point.
- For brake system information (page 17-2).

#### SPECIFICATIONS

Unit: mm (in)

| ITEM                     | STANDARD             | SERVICE LIMIT                               |
|--------------------------|----------------------|---|
| Minimum tire tread depth | -                    | To indicator                                |
| Cold tire pressure       | Driver only          | 200 kPa (2.00 kgf/cm <sup>2</sup> , 29 psi) |
|                          | Driver and passenger | 200 kPa (2.00 kgf/cm <sup>2</sup> , 29 psi) |
| Axle runout              | -                    | 0.2 (0.01)                                  |
| Wheel rim runout         | Radial               | -   |
|                          | Axial                | -   |
| Drive chain              | Size/link            | 420/106                                     |
|                          | Slack                | 30 - 40 (1.2 - 1.6)                         |

#### TORQUE VALUES

##### REAR WHEEL/SUSPENSION

| ITEM                              | Q'TY | THREAD DIA. (mm) | TORQUE N·m (kgf·m, lbf·ft) | REMARKS                            |
|-----------------------------------|------|------------------|----------------------------|------------------------------------|
| Rear axle nut                     | 1    | 12               | 59 (6.0, 44)               | U-nut                              |
| Driven sprocket nut               | 4    | 8                | 32 (3.3, 24)               | U-nut                              |
| Rear brake disc bolt              | 4    | 8                | 42 (4.3, 31)               | ALOC bolt; replace with a new one. |
| Shock absorber upper mounting nut | 1    | 10               | 44 (4.5, 32)               | U-nut                              |
| Shock absorber lower mounting nut | 1    | 10               | 44 (4.5, 32)               | U-nut                              |
| Swingarm pivot nut                | 1    | 12               | 54 (5.5, 40)               | U-nut                              |
| Drive chain slider screw          | 2    | 5                | 6.0 (0.6, 4.4)             |                                    |
| Driven sprocket stud bolt         | 4    | 8                | -                          | See page 16-7                      |

#### TOOLS

|  |  |  |
|--|--|--|
| Attachment, 32 x 35 mm<br>07746-0010100<br> | Attachment, 37 x 40 mm<br>07746-0010200<br>         | Pilot 12 mm<br>07746-0040200<br>        |
| Pilot 17 mm<br>07746-0040400<br>            | Bearing Remover Shaft 9 x 200L<br>07746-0050100<br> | Remover Head 12 mm<br>07746-0050300<br> |

Driver  
07749-0010000



## TROUBLESHOOTING

### Steers to one side or does not track straight

- Drive chain adjusters not adjusted equally
- Bent axle
- Bent frame
- Worn swingarm pivot components

### Rear wheel wobbling

- Bent rim
- Worn wheel bearing
- Worn driven flange bearing
- Faulty tire
- Bent frame or swingarm
- Axle not tightened properly
- Unbalanced tire and wheel
- Insufficient tire pressure

### Wheel hard to turn

- Brake drag
- Faulty wheel bearing
- Faulty driven flange bearing
- Bent axle
- Drive chain too tight

### Soft suspension

- Weak shock absorber spring
- Oil leakage from damper unit
- Insufficient tire pressure

### Stiff suspension

- Bent shock absorber damper rod
- Damaged suspension or swingarm pivot bushing
- Bent swingarm pivot or frame

### Rear suspension noisy

- Loose suspension fasteners
- Faulty shock absorber

## REAR WHEEL/SUSPENSION

### COMPONENT LOCATION

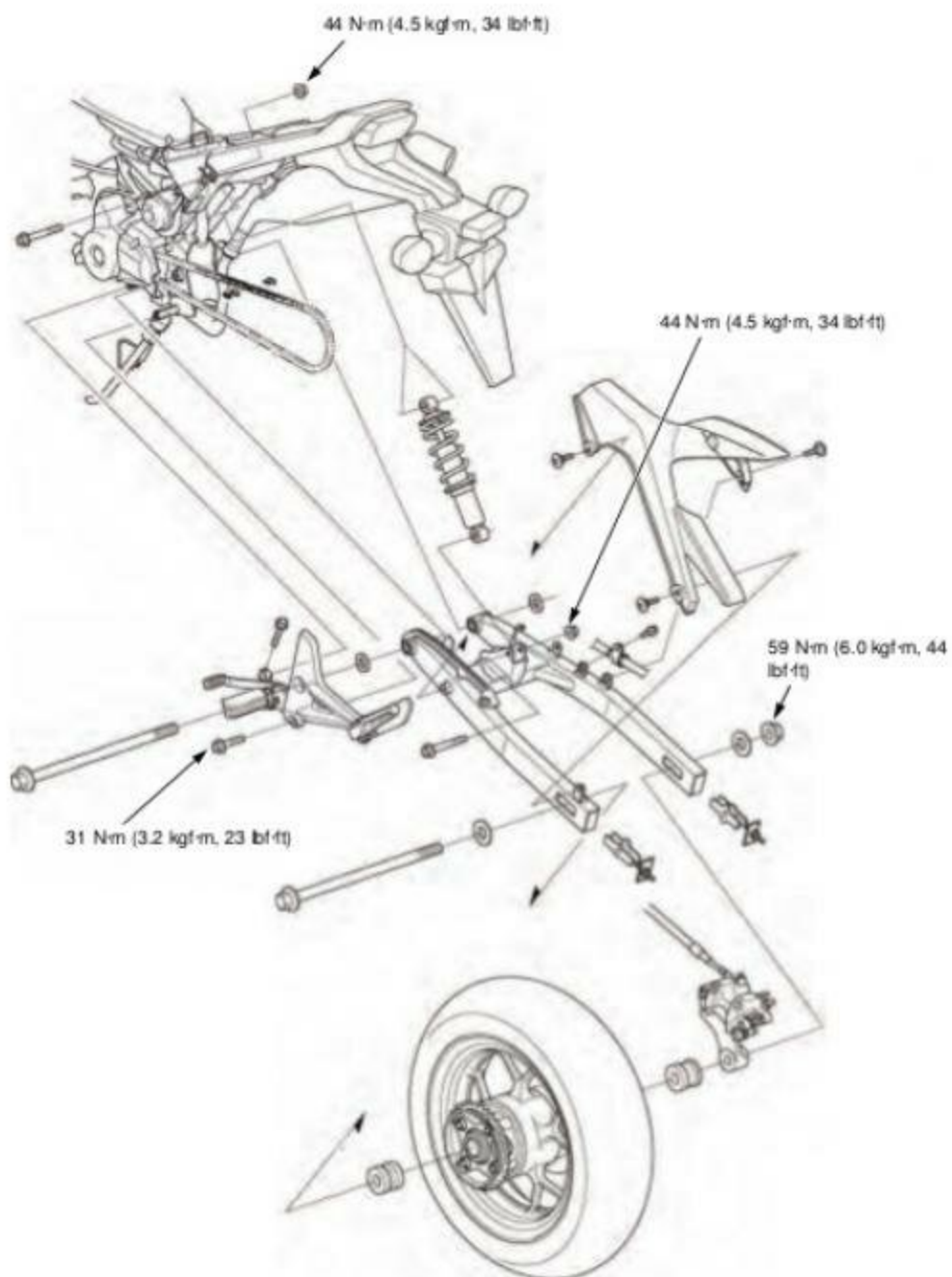

## REAR WHEEL

## REMOVAL

Support the motorcycle using a safety stand or hoist, raise the rear wheel off the ground.

Loosen the rear axle nut [1], both lock nuts [2] and adjusting nut [3].

Push the rear wheel forward.  
Derail the drive chain from the driven sprocket.  
Remove the axle nut, axle and rear wheel.

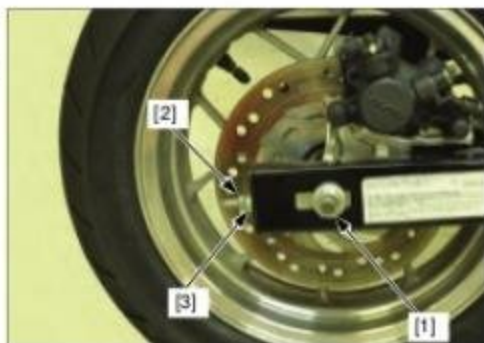

## INSPECTION

Inspect the following parts for damage, abnormal wear, deformation, looseness, smoothly operation or bend.

- Rear axle
- Wheel rim
- Tire
- Wheel and driven flange bearings

## NOTE:

Replace the bearings in pairs.

## DISASSEMBLY/ASSEMBLY

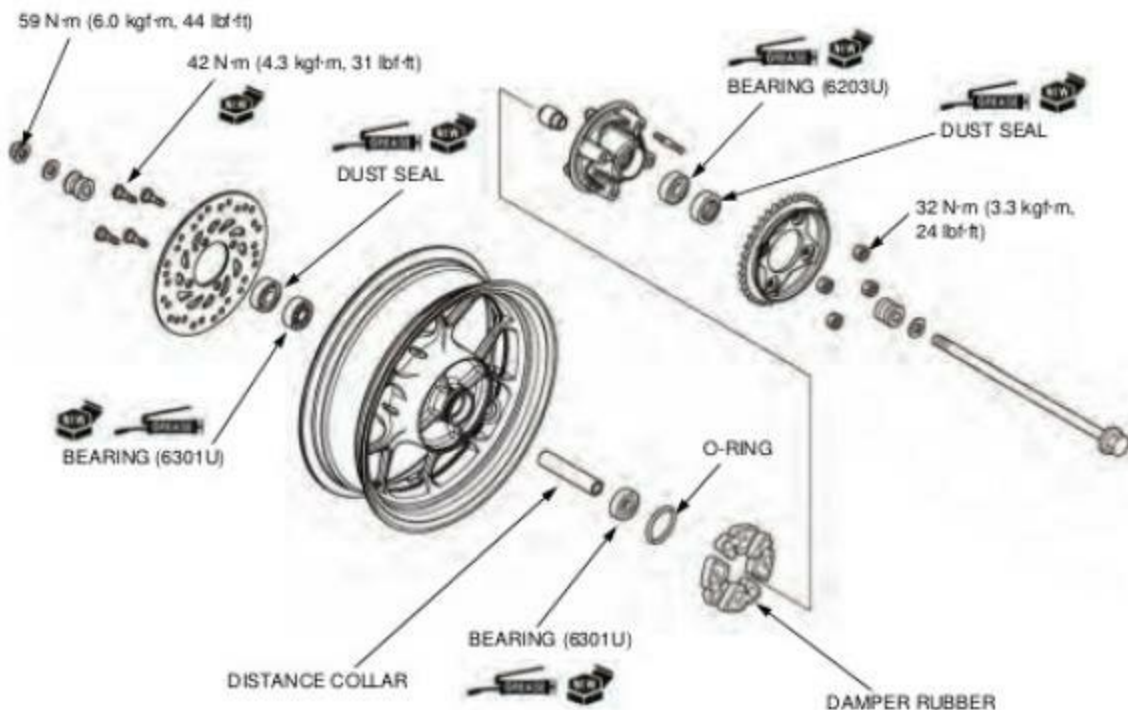

## REAR WHEEL/SUSPENSION

### WHEEL BEARING REPLACEMENT

Install the bearing remover head into the bearing.  
From the opposite side, install the bearing remover shaft and drive the bearing out of the wheel hub.  
Remove the distance collar and drive out the other bearing.

#### TOOLS:

Remover head, 12 mm [1]      07746-0050300  
Bearing remover shaft [2]      07746-0050100

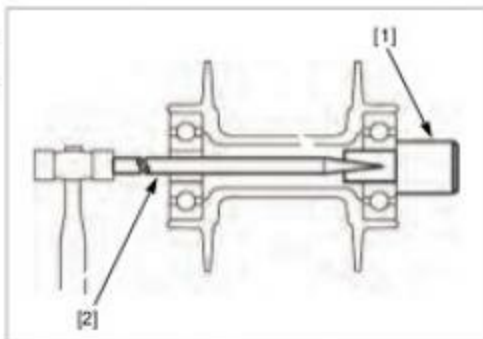

Pack all bearing cavities with grease.

*Never install the old bearings. Once the bearings have been removed, the bearings must be replaced with new ones.*

Drive in a new left bearing [1] squarely with its sealed side facing up until it is fully seated.

#### TOOLS:

Driver [2]      07749-0010000  
Attachment, 32 x 35 mm [3]      07746-0010100  
Pilot, 12 mm [4]      07746-0040200

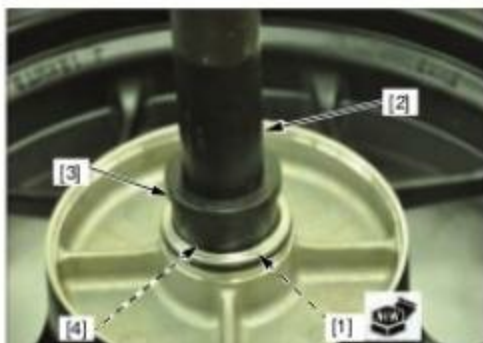

### DRIVEN FLANGE

Remove the driven flange collar [1].

Drive out the driven flange bearing [2].



*Never install the old bearing, once the bearing has been removed, the bearing must be replaced with new ones.*

Drive in a new driven flange bearing squarely until it is fully seated.

#### TOOLS:

Driver      07749-0010000  
Attachment, 37 x 40 mm      07746-0010200  
Pilot, 17 mm      07746-0040400

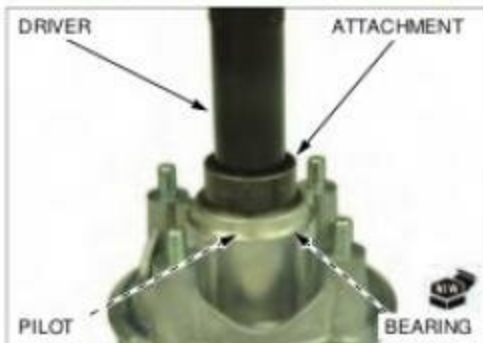

**DRIVEN FLANGE STUD BOLT REPLACEMENT**

Check that the length from the bolt head to the driven flange surface is within specifications.

**STANDARD: 12.2 – 13.2 mm (0.48 – 0.52 in)**

When removing the driven flange stud bolts, install and tighten new stud bolts into the driven flange so that the length from the bolt head to the driven flange surface is within specifications.

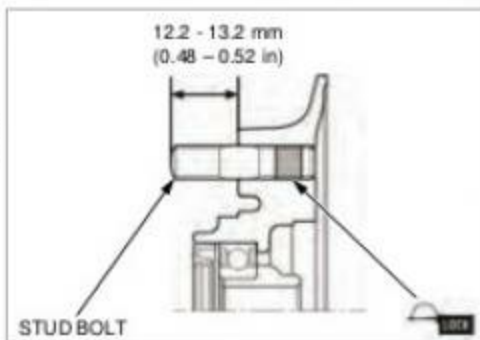
**INSTALLATION**

Check the slot [1] of the brake caliper/bracket assembly is installed to the boss [2] of the swingarm.

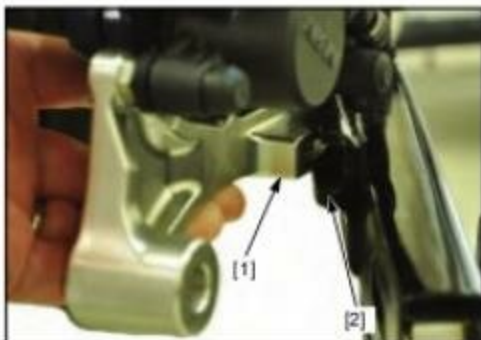

Install the rear wheel in the swingarm aligning the brake disc between the brake pads.

Install the drive chain over the driven sprocket.

Apply a thin coat of grease to the axle rolling surface.

Install the axle from the left side through the axle washer, swingarm, rear wheel and collar.

Install the axle washer and axle nut.

Adjust the drive chain slack (page 3-9).

Tighten the axle nut to the specified torque.

**TORQUE: 59 N·m (6.0 kgf·m, 44 lbf·ft)**

**SHOCK ABSORBER****REMOVAL/INSTALLATION**

Support the motorcycle using a safety stand or hoist, raise the rear wheel off the ground.

Remove the following:

- Right shroud (page 2-4)
- Drive chain cover (page 2-9)
- Rear brake fluid reservoir from the frame
- Regulator/rectifier stay from the frame

Remove the shock absorber lower/upper mounting bolt and nut.

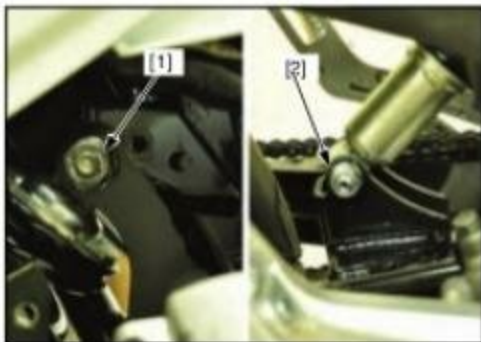

## REAR WHEEL/SUSPENSION

### TORQUE:

- Upper mounting nut [1]: 44 N·m (4.5 kgf·m,  
34 lbf·ft)  
Lower mounting nut [2]: 44 N·m (4.5 kgf·m,  
34 lbf·ft)

### INSPECTION

Visually inspect the shock absorber for wear or damage.

Check the following:

- Damper rod for bend or damage
- Damper unit for deformation or oil leaks
- Bushings for wear or damage
- Rubber bumper for wear or damage

Replace the shock absorber as an assembly if necessary.

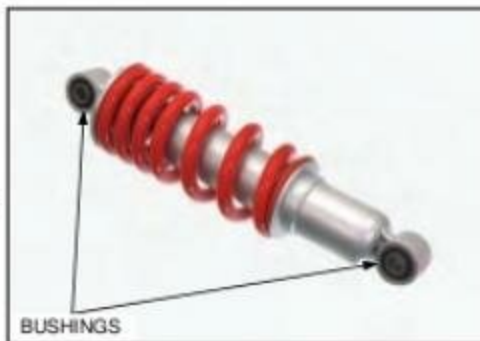

## SWINGARM

### REMOVAL/INSTALLATION

Support the motorcycle using a safety stand or hoist, raise the rear wheel off the ground.

Remove the following:

- Rear wheel (page 16-5)
- Drive chain cover (page 2-9)

Remove the bolt [1] and brake hose guides.

Remove the shock absorber lower mounting bolt and nut.

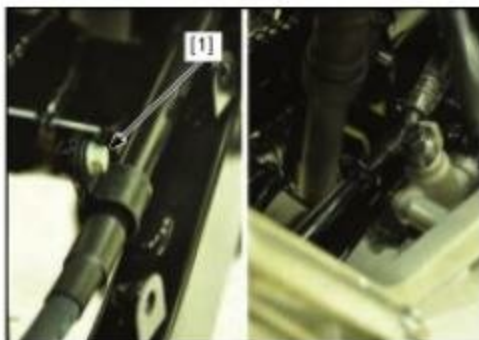

Remove the swingarm pivot nut [1], right step holder mounting bolt [2] and right step holder [3].

Install the swingarm pivot nut [1] to the swingarm pivot shaft.

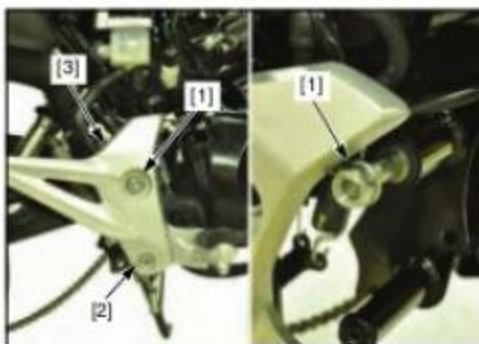

Remove the swingarm pivot nut [1], right step holder mounting bolt [2] and right step holder [3].

Installation is in the reverse order of removal.

### TORQUE:

|                           |                                  |
|---------------------------|----------------------------------|
| Swingarm pivot nut        | 54 N·m (5.5 kgf·m,<br>40 lbf·ft) |
| Step holder mounting bolt | 31 N·m (3.2 kgf·m,<br>23 lbf·ft) |

Adjust the drive chain slack.

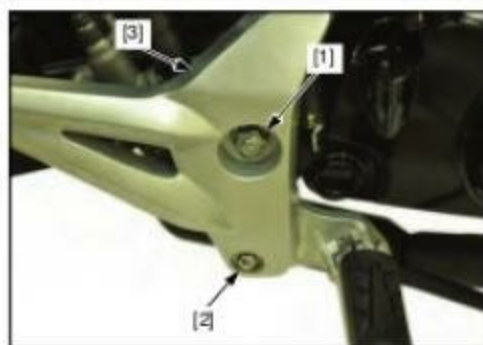

### DISASSEMBLY/ASSEMBLY

#### NOTE:

Bushings are not replaceable. If the bushings are worn or damaged, replace the swingarm.

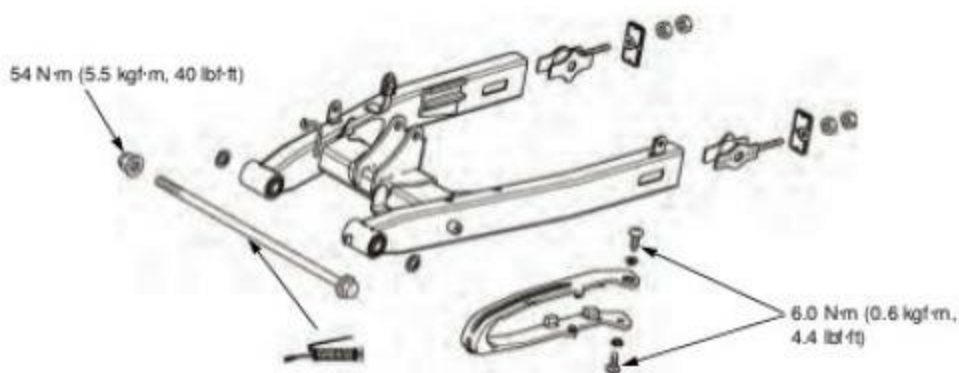

---

**MEMO**

---

# 17. HYDRAULIC BRAKE

---

|  |      |                            |       |
|--|------|----------------------------|-------|
| SERVICE INFORMATION .....                      | 17-2 | FRONT MASTER CYLINDER..... | 17-8  |
| TROUBLESHOOTING.....                           | 17-3 | REAR MASTER CYLINDER ..... | 17-9  |
| COMPONENT LOCATION .....                       | 17-4 | FRONT BRAKE CALIPER .....  | 17-11 |
| BRAKE FLUID REPLACEMENT/<br>AIR BLEEDING ..... | 17-5 | REAR BRAKE CALIPER .....   | 17-13 |
| BRAKE PAD/DISC .....                           | 17-7 | BRAKE PEDAL.....           | 17-14 |

## HYDRAULIC BRAKE

### SERVICE INFORMATION

#### GENERAL

#### **CAUTION**

Frequent inhalation of brake pad dust, regardless of material composition, could be hazardous to your health.

- Avoid breathing dust particles.
- Never use an air hose or brush to clean brake assemblies. Use an OSHA-approved vacuum cleaner.

#### **NOTICE**

Spilling brake fluid will severely damage instrument lenses and painted surface. It is also harmful to some rubber parts. Be careful whenever you remove the reservoir cap; make sure the front reservoir is horizontal first.

- A contaminated brake disc or pad reduces stopping power. Discard contaminated pads and clean a contaminated disc with a high quality brake degreasing agent.
- Check the brake system by applying the brake lever or pedal after the air bleeding.
- Never allow contaminants (dirt, water, etc.) to get into an open reservoir.
- Once the hydraulic system has been opened, or if the brake feels spongy, the system must be bled.
- Always use fresh DOT 3 or DOT 4 brake fluid from a sealed container when servicing the system. Do not mix different types of fluid, they may not be compatible.
- Always check brake operation before riding the motorcycle.

#### SPECIFICATIONS

Unit: mm (in)

|                       | ITEM                              | STANDARD                          | SERVICE LIMIT   |
|-----------------------|-----------------------------------|-----------------------------------|-----------------|
| Front                 | Specified brake fluid             | Honda DOT 4 brake fluid           | -               |
|                       | Brake pad wear indicator          | -                                 | To groove       |
|                       | Brake disc thickness              | 3.3 - 3.7 (0.13 - 0.15)           | 3.0 (0.12)      |
|                       | Brake disc warpage                | -                                 | 0.30 (0.012)    |
|                       | Master cylinder I.D.              | 12.700 - 12.743 (0.5000 - 0.5017) | 12.755 (0.5022) |
|                       | Master piston O.D.                | 12.657 - 12.684 (0.4983 - 0.4994) | 12.640 (0.4976) |
|                       | Caliper cylinder I.D.             | 25.400 - 25.450 (1.0000 - 1.0020) | 25.460 (1.0024) |
| Rear                  | Caliper piston O.D.               | 25.318 - 25.368 (0.9968 - 0.9987) | 25.310 (0.9965) |
|                       | Specified brake fluid             | DOT 3 or DOT 4                    | -               |
|                       | Brake pad wear indicator          | -                                 | To groove       |
|                       | Brake disc thickness              | 3.8 - 4.2 (0.15 - 0.17)           | 3.5 (0.14)      |
|                       | Brake disc warpage                | -                                 | 0.30 (0.011)    |
|                       | Master cylinder I.D.              | 14.000 - 14.043 (0.5512 - 0.5529) | -               |
|                       | Master piston O.D.                | 13.957 - 13.984 (0.5495 - 0.5506) | -               |
| Caliper cylinder I.D. | 27.000 - 27.050 (1.0630 - 1.0650) | -                                 |                 |
| Caliper piston O.D.   | 26.935 - 26.968 (1.0604 - 1.0617) | -                                 |                 |

## TORQUE VALUES

## HYDRAULIC BRAKE

| ITEM                                       | QTY | THREAD DIA. (mm) | TORQUE N·m (kgf·m, lbf·ft) | REMARKS                             |
|--|-----|------------------|----------------------------|-------------------------------------|
| Brake hose oil bolt                        | 4   | 10               | 34 (3.5, 25)               |                                     |
| Master cylinder reservoir cover screw      | 4   | 4                | 1.5 (0.2, 1.1)             |                                     |
| Front brake light switch screw             | 1   | 4                | 1.2 (0.1, 0.2)             |                                     |
| Brake lever pivot bolt                     | 1   | 6                | 1.0 (0.1, 0.7)             |                                     |
| Brake lever pivot nut                      | 1   | 6                | 5.9 (0.6, 4.4)             |                                     |
| Front brake caliper mounting bolt          | 2   | 8                | 30 (3.1, 22)               | ALOC bolt; replace with a new one.  |
| Front brake caliper pin bolt               | 1   | 8                | 17 (1.7, 13)               |                                     |
| Brake pad hanger pin                       | 2   | 10               | 17 (1.7, 13)               |                                     |
| Brake caliper bleed valve                  | 2   | 8                | 5.4 (0.6, 4.0)             |                                     |
| Rear master cylinder push rod lock nut     | 1   | 8                | 17 (1.7, 13)               |                                     |
| Rear master cylinder hose joint screw      | 1   | 4                | 1.5 (0.2, 1.1)             | Apply locking agent to the threads. |
| Step holder mounting bolt                  | 2   | 8                | 31 (3.2, 23)               |                                     |
| Front master cylinder holder bolt          | 2   | 6                | 10 (1.0, 7)                |                                     |
| Rear master cylinder oil cap mounting bolt | 1   | 6                | 10 (1.0, 7)                |                                     |
| Rear master cylinder mounting bolt         | 2   | 6                | 12 (1.2, 9)                | ALOC bolt; replace with a new one.  |

## TROUBLESHOOTING

**Brake lever/pedal soft or spongy**

- Air in hydraulic system
- Leaking hydraulic system
- Contaminated brake pad/disc
- Worn caliper piston seal
- Worn master cylinder piston cups
- Worn brake pad/disc
- Contaminated caliper
- Contaminated master cylinder
- Caliper not sliding properly
- Low brake fluid level
- Clogged fluid passage
- Warped/deformed brake disc
- Sticking/worn caliper piston
- Sticking/worn master cylinder piston
- Bent brake lever/pedal

**Brake lever/pedal hard**

- Clogged/restricted hydraulic system
- Sticking/worn caliper piston
- Caliper not sliding properly
- Worn caliper piston seal
- Sticking/worn master cylinder piston
- Bent brake lever/pedal

**Brake drags**

- Contaminated brake pad/disc
- Misaligned wheel
- Badly worn brake pad/disc
- Warped/deformed brake disc
- Caliper not sliding properly
- Clogged/restricted hydraulic system
- Sticking/worn caliper piston
- Clogged restricted fluid passage
- Sticking caliper piston

## HYDRAULIC BRAKE

### COMPONENT LOCATION

10 N·m (1.0 kgf·m, 7 lbf·ft)

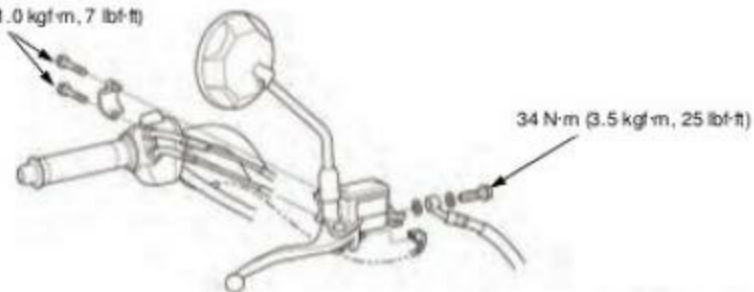

34 N·m (3.5 kgf·m, 25 lbf·ft)

30 N·m (3.1 kgf·m, 22 lbf·ft)

34 N·m (3.5 kgf·m, 25 lbf·ft)

12 N·m (1.2 kgf·m, 9 lbf·ft)

54 N·m (5.5 kgf·m, 40 lbf·ft)

31 N·m (3.2 kgf·m, 23 lbf·ft)

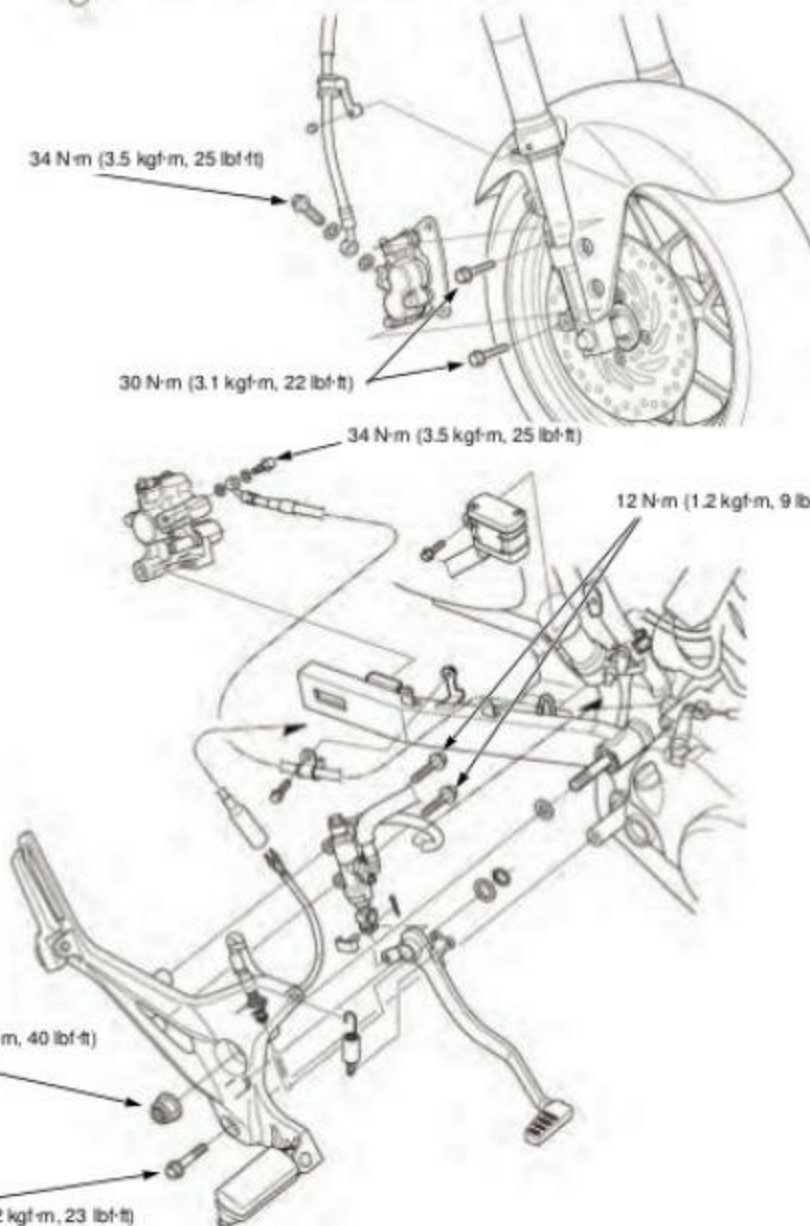

## BRAKE FLUID REPLACEMENT/ AIR BLEEDING

### BRAKE FLUID FILLING/AIR BLEEDING

Fill the reservoir with DOT 3 or DOT 4 brake fluid from a sealed container.

#### NOTE:

- Use only DOT 3 or DOT 4 brake fluid from a sealed container.
- Do not mix different types of fluid. There are not compatible.
- Be sure that each parts is free from the dust or dirt before reassembly.
- When using a brake bleeding tool, follow the manufacturer's operating instructions.

Remove the bolt [1].

Install the reservoir and bolt to shroud mounting stay temporarily [2].

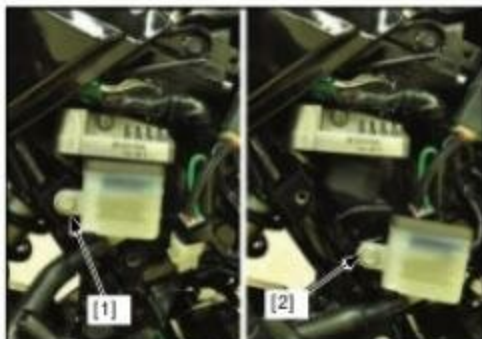

Remove the screws, diaphragm, set plate, reservoir cover.

Connect a automatic refill system to the reservoir.

*Check the fluid level often while bleeding the brake to prevent air from being pumped into the system.*

If an automatic refill system is not used, add fluid when the fluid level in the reservoir is low.

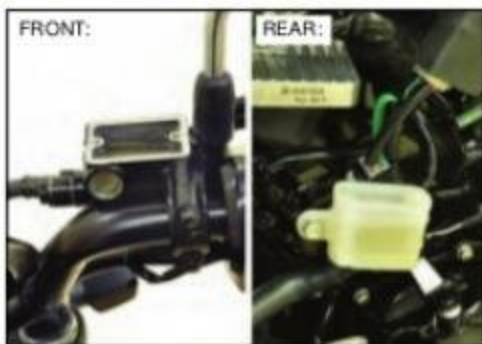

Connect a commercially available brake bleeder to the bleed valve.

Operate the brake bleeder and loosen the bleed valve.

*If air enters the bleeder from around the bleed valve threads, seal the threads with teflon tape.*

Perform the bleeding procedure until the system is completely flushed/bled.

Close the bleed valve and operate the brake lever/pedal. If it still feels spongy, bleed the system again.

After bleeding the system completely, tighten the brake caliper bleed valve to the specified torque.

**TORQUE: 5.4 N·m (0.6 kgf·m, 4.0 lbf·ft)**

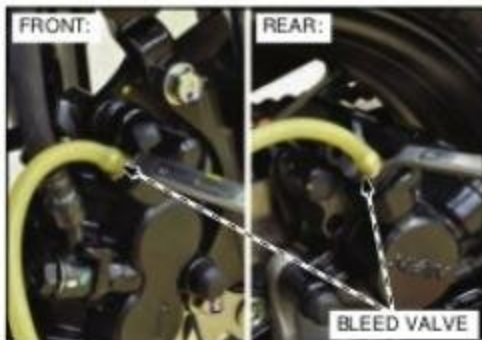

## HYDRAULIC BRAKE

If the brake bleeder is not available, perform the following procedure.

Pump up the system pressure with the brake lever/pedal until the lever/pedal resistance is felt.

Connect a bleed hose to the bleed valve.

1. Squeeze the brake lever/pedal all the way and loosen the bleed valve 1/2 turn. Wait several seconds and then close the bleed valve.

**NOTE:**

- Do not release the brake lever/pedal until the bleed valve has been closed.
2. Release the brake lever/pedal slowly and wait several seconds after it reaches the end of its travel.
  3. Repeat the steps 1 and 2 until there are no air bubbles in the bleed hose.

After bleeding the system completely, tighten the brake caliper bleed valve to the specified torque.

**TORQUE: 5.4 N·m (0.6 kgf·m, 4.0 lbf·ft)**

*Do not mix different types of fluid. They are not compatible.*

Add the reservoir with DOT 3 or DOT 4 brake fluid to the casting ledge/upper level line.

Install the diaphragm, set plate, reservoir cover and reservoir cover screws, then tighten the screws to the specified torque.

**TORQUE: 1.5 N·m (0.2 kgf·m, 1.1 lbf·ft)**

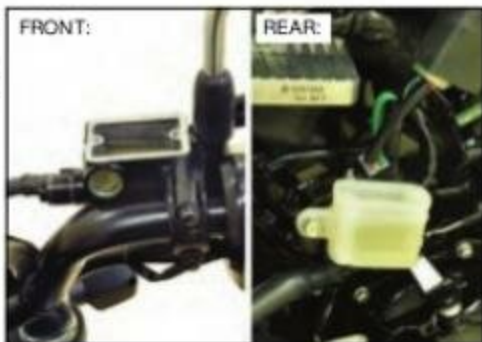
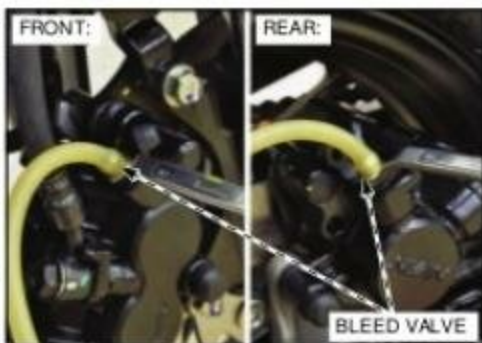

*Rear reservoir:* Install the reservoir and bolt [1] to the specified torque.

**TORQUE: 12 N·m (1.2 kgf·m, 9 lbf·ft)**



## BRAKE PAD/DISC

### FRONT BRAKE PAD REPLACEMENT

#### REMOVAL/INSPECTION

*Do not operate the brake lever after removing the brake pads.*

Remove the brake pad hanger pin [1] and brake pads.

Check that the O-ring [2] is in good condition, replace if necessary.

#### INSTALLATION

##### NOTE:

Make sure that the retainer is installed to the brake caliper.

Apply silicone grease to the brake pad hanger pin O-ring and install it to the hanger pin groove.

Install the brake pad hanger pin by pushing the pads against the pad spring to align the hanger pin holes in the pads and brake caliper.

Tighten the brake pad hanger pin to the specified torque.

**TORQUE: 17 N·m (1.7 kgf·m, 13 lbf·ft)**

Operate the brake lever to seat the caliper pistons against the pads.



### REAR BRAKE PAD REPLACEMENT

*Do not operate the brake pedal after removing the brake pads.*

Remove the rubber plug [1], hanger pin [2], and brake pads [3].

Check that the O-ring is in good condition, replace it if necessary.

##### NOTE:

Make sure that the retainer is installed to the brake caliper.

Install brake pads to the brake caliper so their ends seat against the retainer.

Apply silicone grease to the brake pad hanger pin O-ring and install it to the pad pin groove.

Install the brake pad hanger pin by pushing the pads against the pad spring to align the hanger pin holes in the pads and brake caliper.

Tighten the brake pad hanger pin to the specified torque.

**TORQUE: 17 N·m (1.7 kgf·m, 13 lbf·ft)**

Install the rubber plug.

Operate the brake pedal to seat the caliper pistons against the pads.



### BRAKE DISC INSPECTION

Visually inspect the brake discs for damage or crack.

Measure the brake disc according to BRAKE SYSTEM SPECIFICATIONS (page 1-9) and replace if necessary.

## HYDRAULIC BRAKE

### FRONT MASTER CYLINDER

#### REMOVAL

Drain the brake fluid from the hydraulic system (page 17-5).

*When removing the oil bolt, cover the end of the brake hose to prevent contamination.*

Disconnect the brake light switch connectors.

Remove the brake hose oil bolt [1], sealing washers [2] and brake hose eyelet.

Remove the bolts [3], holder and master cylinder.

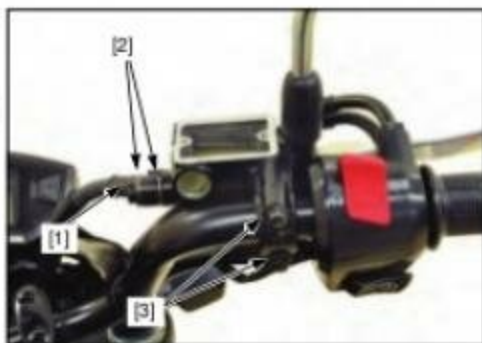

#### DISASSEMBLY/ASSEMBLY

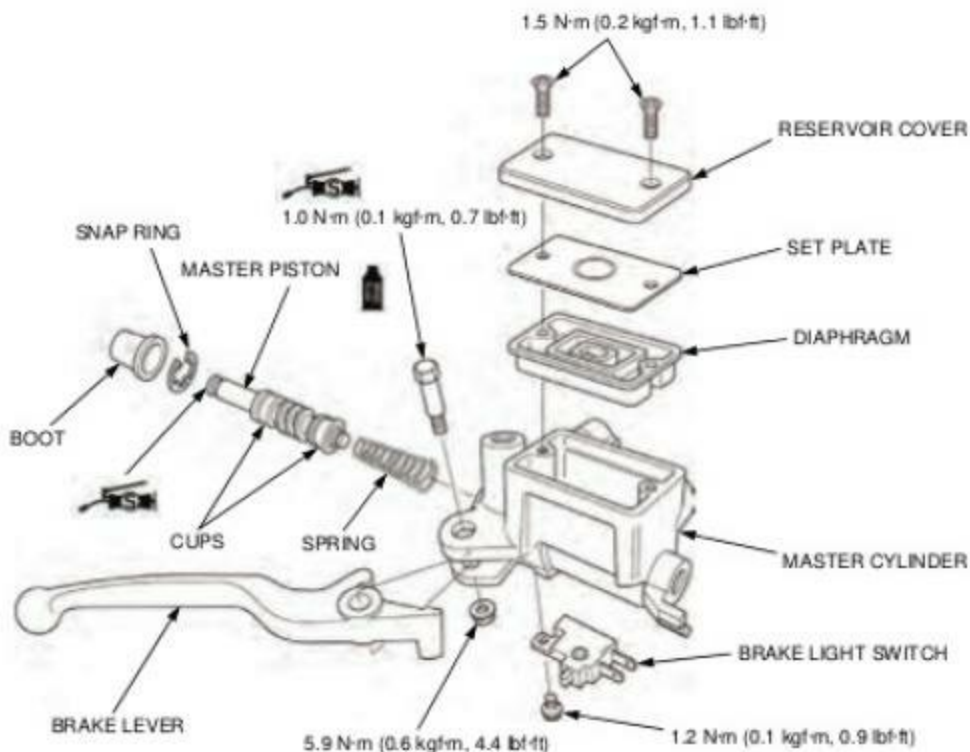

#### INSPECTION

Inspect the following parts for scoring, scratches, deterioration or damage.

- master cylinder
- master piston
- piston cups

#### NOTE:

Replace the piston, cups and washer as a set.

Measure the brake disc according to BRAKE SYSTEM SPECIFICATIONS (page 1-9) and replace if necessary.

**INSTALLATION**

Install the master cylinder, holder ("UP" mark facing up) and bolts.

Align the end of the master cylinder with the punch mark on the handlebar, and tighten the upper bolt first, then the lower bolt.

Connect the brake light switch connectors.

Install the brake hose eyelet with the brake hose oil bolt [1] and new sealing washers [2].

Push the brake hose eyelet joint against the stopper, then tighten the brake hose oil bolt to the specified torque.

**TORQUE: 34 N·m (3.5 kgf·m, 25 lbf·ft)**

Fill the reservoir to the upper level and bleed the front brake system (page 17-5).

**REAR MASTER CYLINDER****REMOVAL**

Drain the brake fluid from the hydraulic system (page 17-5).

*When removing the oil bolt, cover the end of the brake hose to prevent contamination.*

Remove the brake hose oil bolt [1], sealing washers [2] and brake hose eyelet.

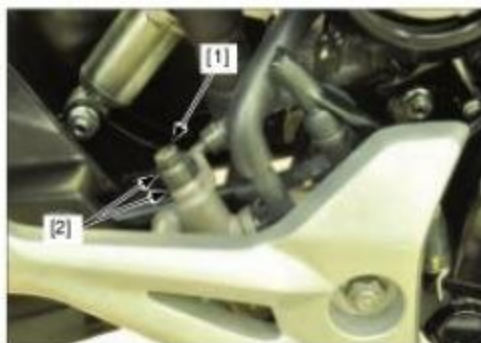

Remove the step holder mounting bolt [1], swingarm pivot nut [2] and right step holder assembly.

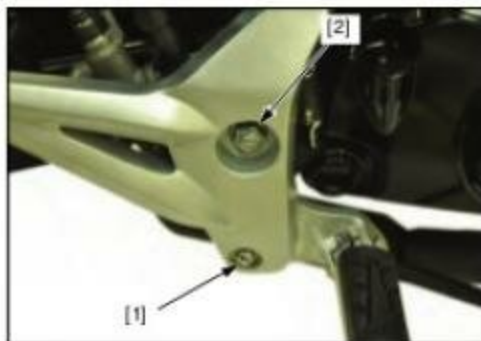

Remove and discard the brake pedal joint cotter pin [1].

Remove the joint pin [2] and disconnect the push rod lower joint from the brake pedal.

Remove the master cylinder mounting bolts [3] and master cylinder from the right step holder assembly.



## HYDRAULIC BRAKE

### DISASSEMBLY/ASSEMBLY

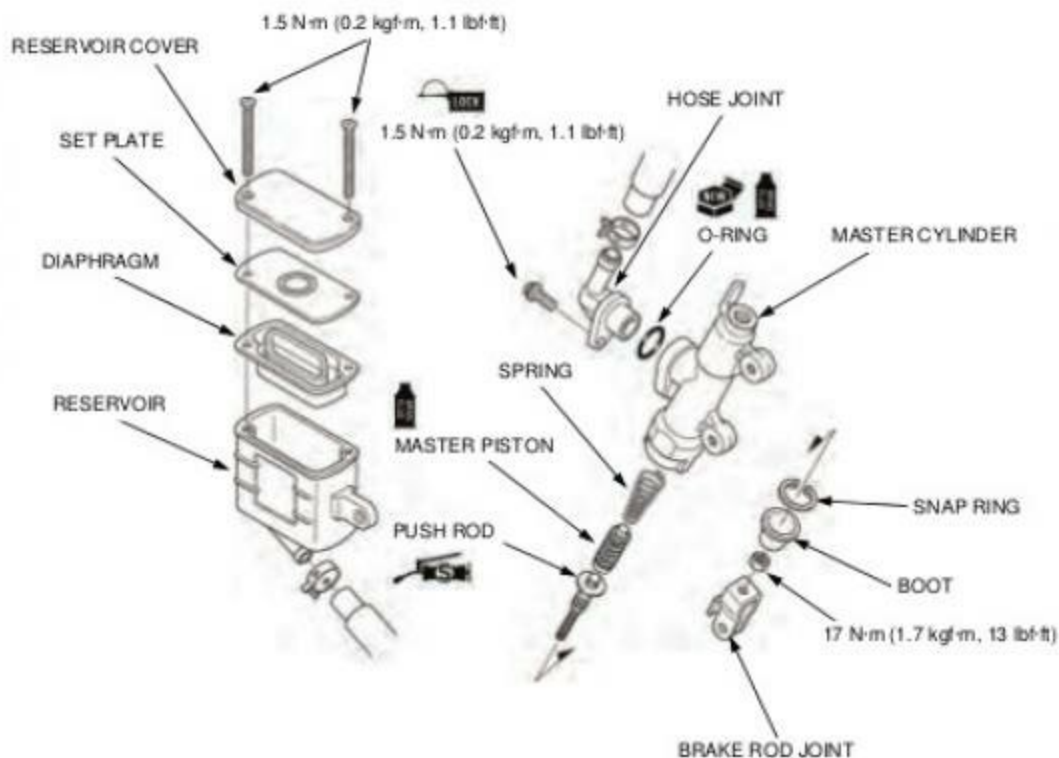

Apply silicone grease to the boot groove of the push rod.

Install the boot securely.

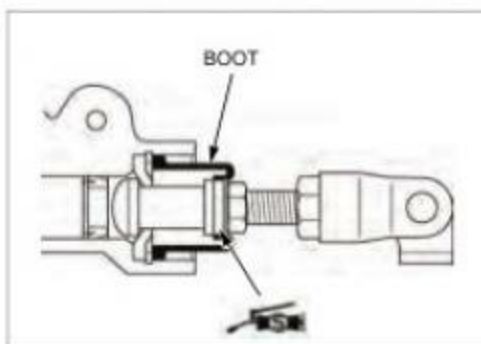

If the push rod joint is reinstalled, adjust the push rod length so that the distance from the center of the master cylinder lower mounting hole to the center of the joint pin hole is 64 – 66 mm (2.5 – 2.6 in) as shown.

After adjustment tighten the push rod lock nut to the specified torque.

**TORQUE: 17 N·m (1.7 kgf·m, 13 lbf·ft)**

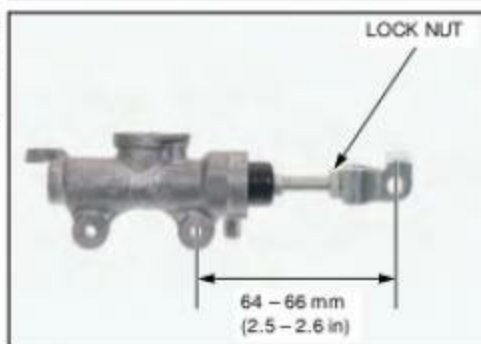

**INSPECTION**

Inspect the following parts for scoring, scratches, deterioration or damage.

- master cylinder
- master piston
- piston cups
- push rod
- Boot
- Rod joint

**NOTE:**

Replace the piston, cups and washer as a set.

Measure the brake disc according to BRAKE SYSTEM SPECIFICATIONS (page 1-9) and replace if necessary.

**INSTALLATION**

Install and tighten the master cylinder and master cylinder mounting bolts [1] to the right step holder assembly.

Connect the push rod lower joint to the brake pedal. Install the joint pin [2] and new cotter pin [3].

Install the right step holder assembly, swingarm pivot nut step holder mounting bolts. Tighten the bolts to the specified torque.

**TORQUE:**

|                            |                               |
|----------------------------|-------------------------------|
| Swing arm pivot nut:       | 54 N·m (5.5 kgf·m, 40 lbf·ft) |
| Step holder mounting bolt: | 31 N·m (3.2 kgf·m, 23 lbf·ft) |

Install the brake hose eyelet with the brake hose oil bolt and new sealing washers [1].

Push the brake hose eyelet joint against the stopper, then tighten the brake hose oil bolt [2] to the specified torque.

**TORQUE: 34 N·m (3.5 kgf·m, 25 lbf·ft)**

Fill the reservoir to the upper level and bleed the rear brake system (page 17-5).

**FRONT BRAKE CALIPER****REMOVAL/INSTALLATION**

Drain the brake fluid from the hydraulic system (page 17-5).

Remove the brake pads (page 17-7).

*When removing the oil bolt, cover the end of brake hose to prevent contamination.*

Remove the brake hose oil bolt [1], sealing washers [2] and brake hose eyelet.

Remove the brake caliper mounting bolts [3] and brake caliper/bracket assembly.

Install the brake caliper/bracket assembly.

Install new mounting bolts [3] and tighten them to the specified torque.

**TORQUE: 30 N·m (3.1 kgf·m, 22 lbf·ft)**

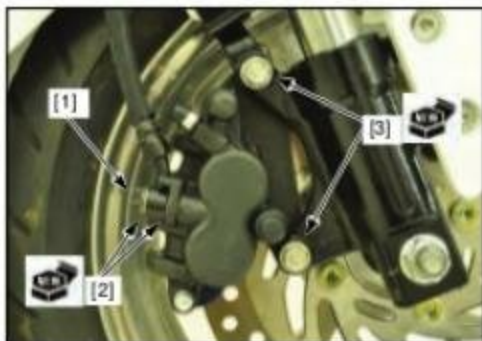

## HYDRAULIC BRAKE

Install the brake hose eyelet between the stoppers with brake hose oil bolt and new sealing washers [2].  
Tighten the brake hose oil bolt [1] to the specified torque.

**TORQUE: 34 N·m (3.5 kgf·m, 25 lbf·ft)**

Install the brake pads (page 17-7).

Fill the reservoir to the upper level and bleed the front brake system (page 17-5).

### DISASSEMBLY/ASSEMBLY

#### NOTE:

- Do not use high pressure air or bring the nozzle too close to the inlet.
- Be careful not to damage the piston sliding surface.

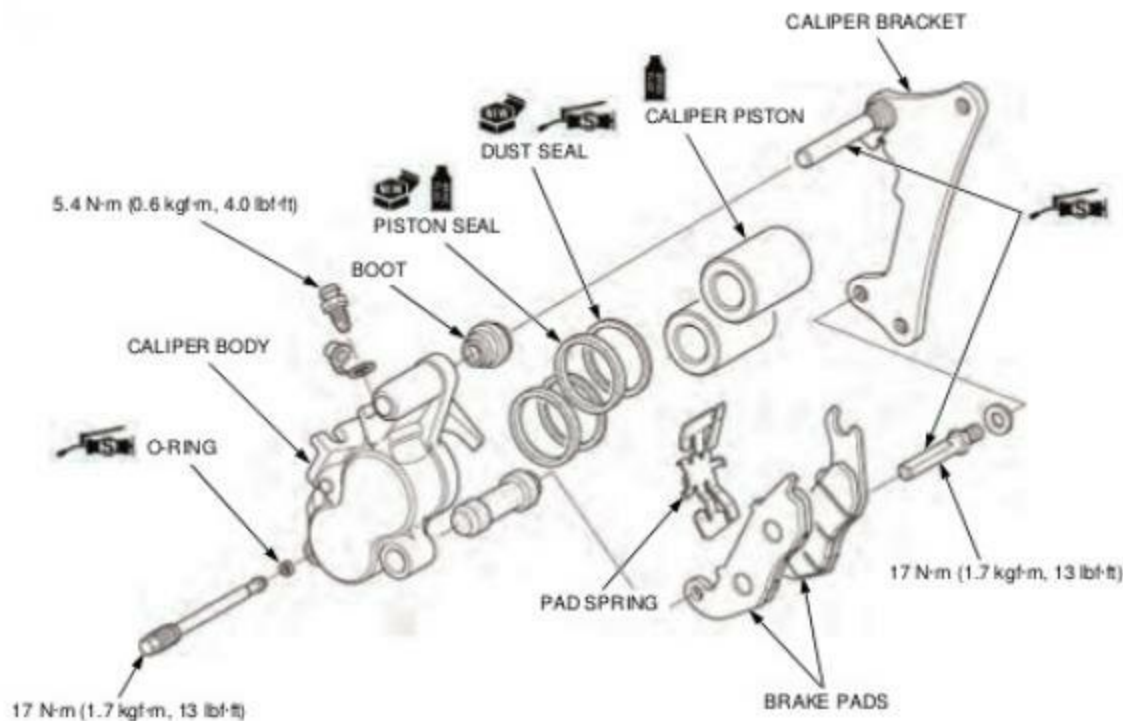

### INSPECTION

Inspect the following parts for scoring, scratches or damage.

- caliper cylinders
- caliper pistons

Measure the brake disc according to BRAKE SYSTEM SPECIFICATIONS (page 1-9) and replace if necessary.

## REAR BRAKE CALIPER

### REMOVAL/INSTALLATION

Drain the brake fluid from the hydraulic system (page 17-5).

Remove the brake pads (page 17-7).

*When removing the oil bolt, cover the end of brake hose to prevent contamination.*

Remove the brake hose oil bolt [1] and sealing washers [2].

Remove the rear wheel (page 16-5).

Remove the brake caliper/bracket assembly.

Install the rear wheel (page 16-7).

Install the brake hose eyelet between the stoppers with brake hose oil bolt [1] and new sealing washers [2].

Tighten the brake hose oil bolt [1] to the specified torque.

**TORQUE: 34 N·m (3.5 kgf·m, 25 lbf·ft)**

Install the brake pads (page 17-7).

Fill the reservoir to the upper level and bleed the rear brake system (page 17-5).

### DISASSEMBLY/ASSEMBLY

#### NOTE:

- Do not use high pressure air or bring the nozzle too close to the inlet.
- Be careful not to damage the piston sliding surface.

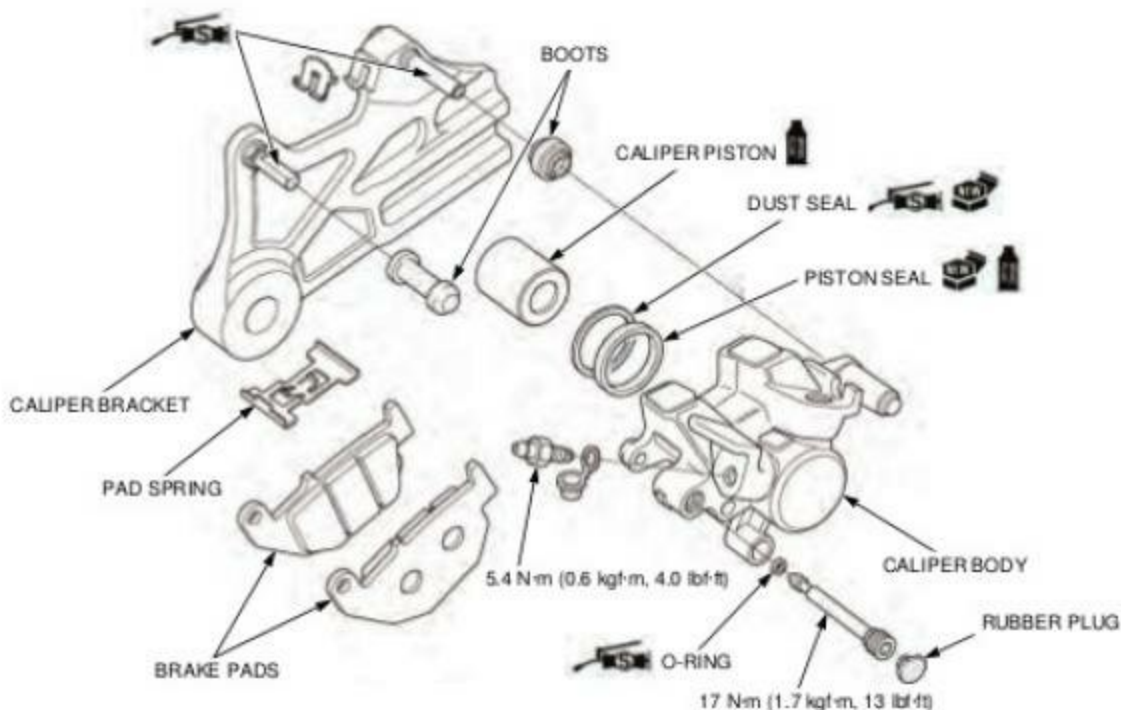
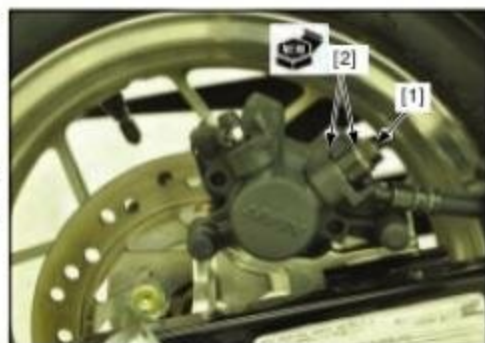

## HYDRAULIC BRAKE

---

### INSPECTION

Inspect the following parts for scoring, scratches or damage.

- caliper cylinder
- caliper piston

Measure the brake disc according to BRAKE SYSTEM SPECIFICATIONS (page 1-9) and replace if necessary.

## BRAKE PEDAL

### REMOVAL/INSTALLATION

Remove the step holder mounting bolts [1] and swingarm pivot nut [2] and right step holder assembly.

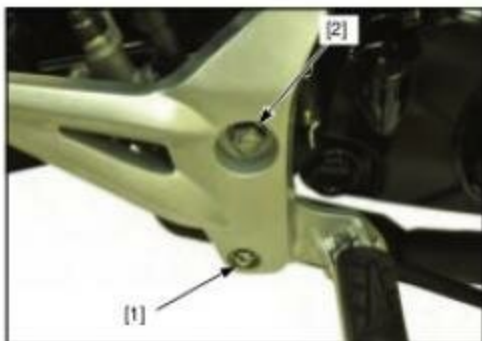

Unhook the brake light switch spring [1] from the brake pedal return spring [2].

Remove the snap ring [3], washer and brake pedal.

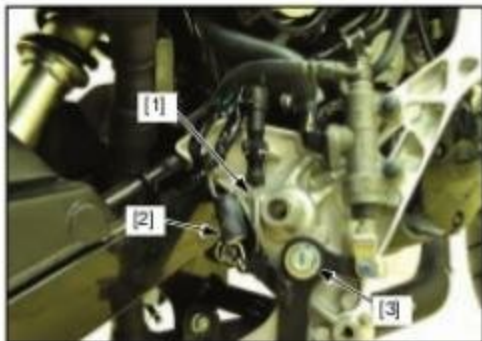

## DISASSEMBLY/ASSEMBLY

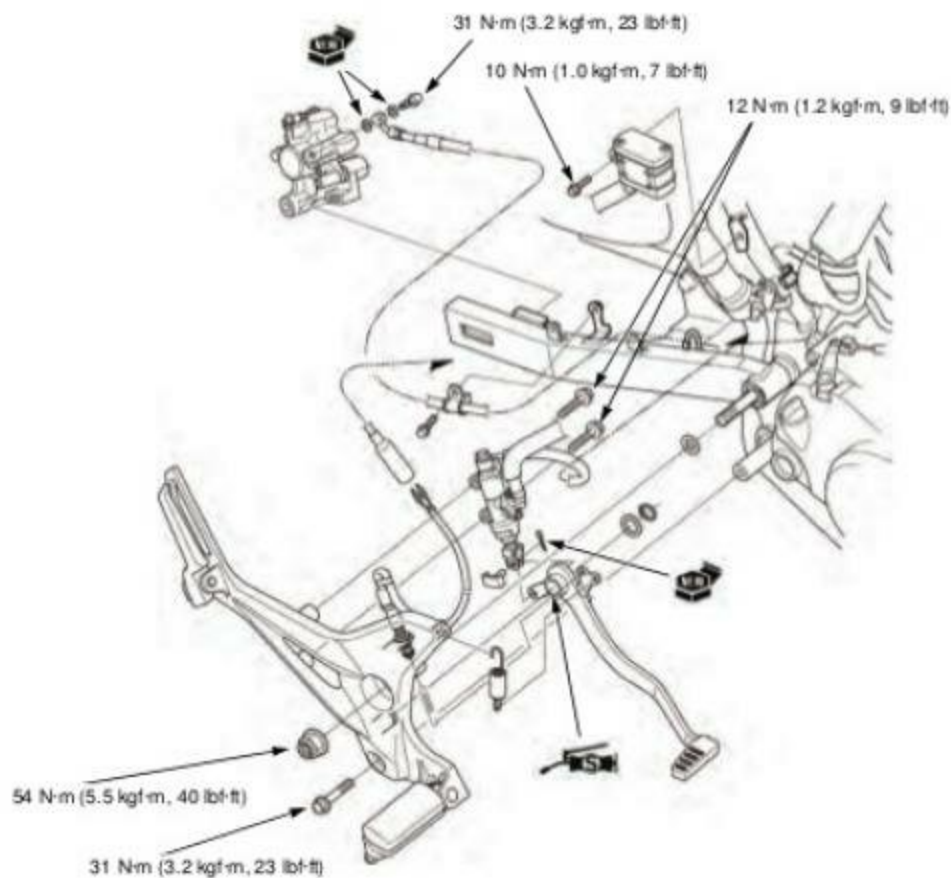

---

**MEMO**

---

# 18. BATTERY/CHARGING SYSTEM

---

|                           |      |                                  |      |
|---------------------------|------|----------------------------------|------|
| SERVICE INFORMATION ..... | 18-2 | BATTERY .....                    | 18-5 |
| TROUBLESHOOTING.....      | 18-3 | CHARGING SYSTEM INSPECTION ..... | 18-5 |
| SYSTEM LOCATION.....      | 18-4 | ALTERNATOR CHARGING COIL .....   | 18-6 |
| SYSTEM DIAGRAM .....      | 18-4 | REGULATOR/RECTIFIER .....        | 18-7 |

## BATTERY/CHARGING SYSTEM

# SERVICE INFORMATION

### GENERAL

#### **▲ WARNING**

- The battery gives off explosive gases; keep sparks, flames and cigarettes away. Provide adequate ventilation when charging.
- The battery contains sulfuric acid (electrolyte). Contact with skin or eyes may cause severe burns. Wear protective clothing and a face shield.
  - If electrolyte gets on your skin, flush with water.
  - If electrolyte gets in your eyes, flush with water for at least 15 minutes and call a physician immediately.
- Electrolyte is poisonous.
  - If swallowed, drink large quantities of water or milk and call your local Poison Control Center or call a physician immediately.

#### **NOTICE**

- Always turn OFF the ignition switch before disconnecting any electrical component.
- Some electrical components may be damaged if terminals or connectors are connected or disconnected while the ignition switch is ON position and current is present.
- For extended storage, remove the battery, give it a full charge, and store it in a cool, dry space. For maximum service life, charge the stored battery every two weeks.
- For a battery remaining in a stored motorcycle, disconnect the negative battery cable from the battery terminal.
- The maintenance free (MF) battery must be replaced when it reaches the end of its service life.
- The battery can be damaged if overcharged or undercharged, or if left to discharge for long period. These same conditions contribute to shortening the "life span" of the battery. Even under normal use, the performance of the battery deteriorates after 2 – 3 years.
- Battery voltage may recover after battery charging, but under heavy load, the battery voltage will drop quickly and eventually die out. For this reason, the charging system is often suspected as the problem. Battery overcharge often results from problems in the battery itself, which may appear to be an overcharging symptom. If one of the battery cells is shorted and battery voltage does not increase, the regulator/rectifier supplies excess voltage to the battery. Under these conditions, the electrolyte level goes down quickly.
- Before troubleshooting the charging system, check for proper use and maintenance of the battery. Check if the battery is frequently under heavy load, such as having the turn signal and brake lights on for long periods of time without riding the motorcycle.
- The battery will self-discharge when the motorcycle is not in use. For this reason, charge the battery every two weeks to prevent sulfation from occurring.
- When checking the charging system, always follow the steps in the troubleshooting.

#### **BATTERY CHARGING**

- Turn power ON/OFF at the charger, not at the battery terminal.
- For battery charging, do not exceed the charging current and time specified on the battery. Using excessive current or extending the charging time may damage the battery.
- Quick charging should only be done in an emergency; slow charging is preferred.

#### **BATTERY TESTING**

Refer to the instruction of the Operation Manual for the recommended battery tester for details about battery testing. The recommended battery tester puts a "load" on the battery so that the actual battery condition during load can be measured.

**Recommended battery tester: BM-210 or BATTERY MATE or equivalent**

## SPECIFICATIONS

| ITEM       |                                      | SPECIFICATIONS                        |                |
|------------|--------------------------------------|---------------------------------------|----------------|
| Battery    | Type                                 | YTZ5S                                 |                |
|            | Capacity                             | 12 V - 3.5 Ah (10 HR)                 |                |
|            | Current leakage                      | 0.01 mA                               |                |
|            | Voltage<br>(20°C/68°F)               | Fully charged                         | 13.0 - 13.2 V  |
|            |                                      | Needs charging                        | Below 12.4 V   |
|            | Charging current                     | Normal                                | 0.5 A/5 - 10 h |
| Quick      |                                      | 2.5 A/1 h                             |                |
| Alternator | Capacity                             | 0.18 kW/5,000 min <sup>-1</sup> (rpm) |                |
|            | Charging coil resistance (20°C/68°F) | 0.2 - 1.0 Ω                           |                |

## TROUBLESHOOTING

| Unusual condition                     | Probable cause (Check in numerical order)  |
|---------------------------------------|--|
| Battery<br>Battery is damaged or weak | <ol style="list-style-type: none"> <li>Faulty battery</li> <li>Current leakage higher than specified value               <ul style="list-style-type: none"> <li>- Faulty ignition switch</li> <li>- Shorted wire harness</li> </ul> </li> <li>Faulty alternator charging coil</li> <li>Faulty regulator/rectifier</li> <li>Open circuit or loose connection in the wire harness</li> </ol> |

## BATTERY/CHARGING SYSTEM

### SYSTEM LOCATION

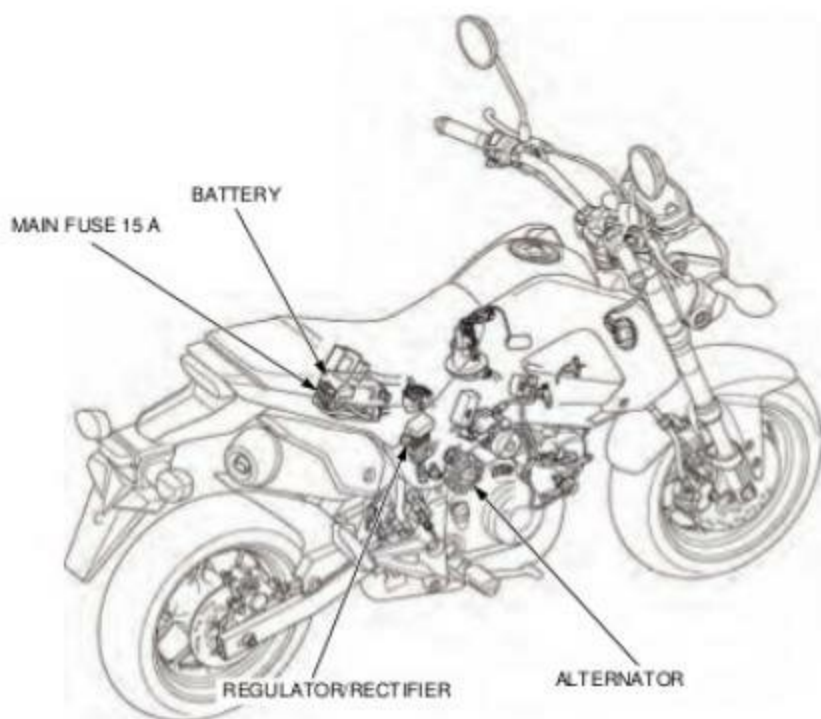

### SYSTEM DIAGRAM

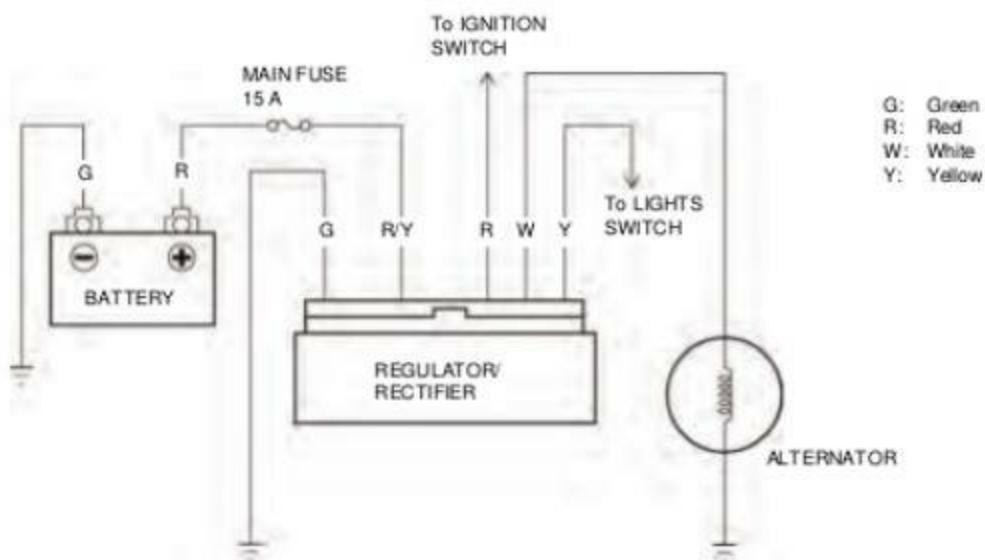

## BATTERY

### REMOVAL/INSTALLATION

- Always turn the ignition switch OFF before removing the battery.
- Always disconnect the negative terminal first.
- Connect the positive (+) cable to the battery first, then connect the negative (-) cable.

Remove the seat (page 2-3).

Remove the bolt [1] and battery holder plate [2] and battery.

Installation is in the reverse order of removal.

#### NOTE:

- Install the battery holder plate by aligning its hook with the slit of the rear fender.
- For digital clock setting procedure (page 19-6).

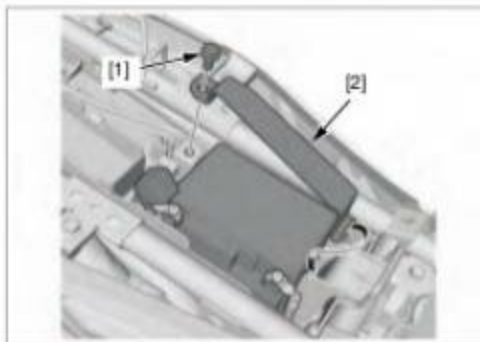

### VOLTAGE INSPECTION

Measure the battery voltage using a commercially available digital multimeter.

#### VOLTAGE (20°C/68°F):

- Fully charged: 13.0 – 13.2 V
- Needs charging: Below 12.4 V

#### NOTE:

- When measuring the battery voltage after charging, leave it for least 30 minutes, or the accurate results cannot be obtained because the battery voltage fluctuates just after charging.

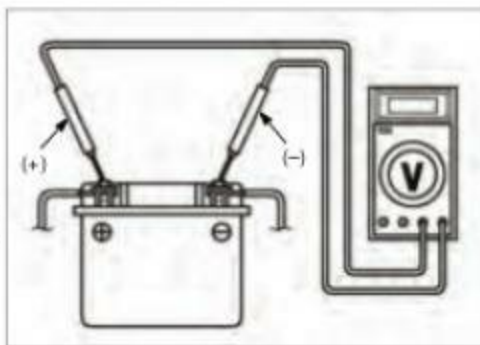

### BATTERY TESTING

Refer to the instructions that are appropriate to the battery testing equipment available to you.

#### TOOL:

Battery tester BM-210, BATTERY MATE or equivalent

## CHARGING SYSTEM INSPECTION

### CURRENT LEAKAGE TEST

Remove the seat (page 2-3).

Turn the ignition switch OFF and disconnect the negative (-) cable [1] from the battery.

Connect the ammeter (+) probe to the negative cable and the ammeter (-) probe to the battery (-) terminal. With the ignition switch OFF, check for current leakage.

#### NOTE:

- When measuring current using a tester, set it to a high range, and then bring the range down to an appropriate level. Current flow higher than the range selected may blow the fuse in the tester.
- While measuring current, do not turn the ignition switch ON. A sudden surge of current may blow the fuse in the tester.

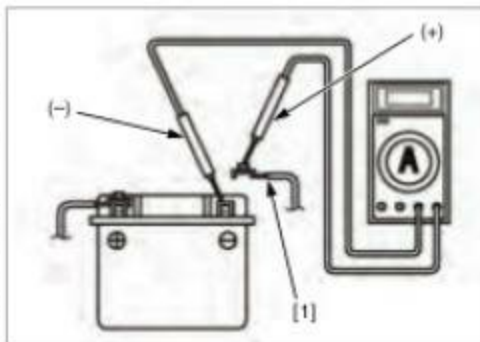

## BATTERY/CHARGING SYSTEM

If current leakage exceeds the specified value (page 1-9), a shorted circuit is the probable cause. Locate the short by disconnecting connections one by one and measuring the current.

### CHARGING VOLTAGE INSPECTION

Remove the seat (page 2-3).

#### NOTE:

Make sure the battery is in good condition before performing this inspection.

Warm up the engine to normal operating temperature. Stop the engine and connect the multimeter as shown.

#### NOTE:

To prevent a short, make absolutely certain which are the positive and negative terminals or cables.

Connect a tachometer according to its manufacturer's instructions.

Restart the engine.

Measure the voltage on the multimeter when the engine runs at  $5,000 \text{ min}^{-1}$  (rpm).

#### STANDARD:

Measured BV < Measured CV < 15.5 V

- BV = Battery Voltage (page 18-5)
- CV = Charging Voltage

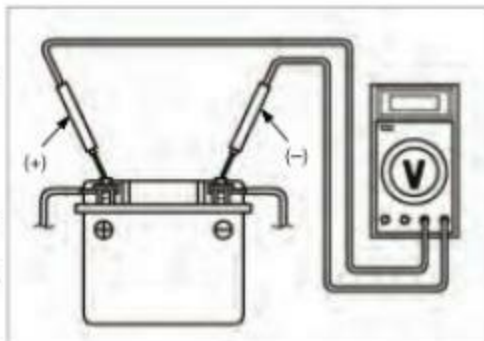

*Do not disconnect the battery or any cable in the charging system without first switching OFF the ignition switch. Failure to follow this precaution can damage the tester or electrical components.*

## ALTERNATOR CHARGING COIL INSPECTION

Remove the right shroud (page 2-4).

Disconnect the alternator connector [1].



Check the resistance between the alternator 4P connector [1] White and Green wire terminals of the alternator side.

**STANDARD: 0.2 – 1.0  $\Omega$  (at 20°C/68°F)**

Replace the stator if the resistance is out of specification.

Install the right shroud (page 2-4).

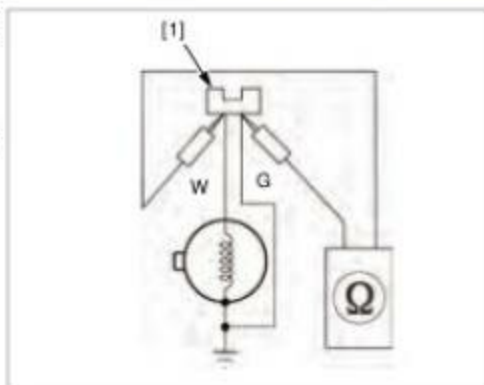

## REGULATOR/RECTIFIER

## SYSTEM INSPECTION

Remove the shroud (page 2-4).

Turn the ignition switch OFF.

Disconnect the regulator/rectifier connector 6P [1].

Check it for loose contact or corroded terminals.

If the charging voltage reading (page 1 8-6) is out of the specification, inspect the regulator/rectifier connector terminals (wire harness side) as follows:

| Item                  | Terminal                      | Specification                        |
|-----------------------|-------------------------------|--------------------------------------|
| Battery charging line | Red/yellow (+) and Ground (-) | Battery voltage should appear        |
| Charging coil line    | White and Green               | 0.2 – 1.0 $\Omega$<br>(at 20°C/68°F) |
| Ground line           | Green and Ground              | Continuity should exist              |

If all components of the charging system is normal and there are no loose connections at the regulator/rectifier connector, replace the regulator/rectifier unit.

Install the right shroud (page 2-4).

## REMOVAL/INSTALLATION

Remove the shroud (page 2-4).

Turn the ignition switch OFF.

Disconnect the regulator/rectifier connector 6P [1].

Remove the bolts [2] and regulator/rectifier from the frame.

Installation is in the reverse order of removal.



---

**MEMO**

---

# 19. LIGHTS/METERS/SWITCHES

---

|                           |      |                                       |       |
|---------------------------|------|---------------------------------------|-------|
| SERVICE INFORMATION ..... | 19-2 | FUEL GAUGE/<br>FUEL LEVEL SENSOR..... | 19-7  |
| SYSTEM LOCATION.....      | 19-3 | IGNITION SWITCH.....                  | 19-8  |
| HEADLIGHT .....           | 19-4 | HANDLEBAR SWITCHES .....              | 19-9  |
| TURN SIGNAL LIGHT.....    | 19-4 | BRAKE LIGHT SWITCH.....               | 19-9  |
| BRAKE/TAILLIGHT.....      | 19-4 | NEUTRAL SWITCH .....                  | 19-10 |
| LICENSE LIGHT.....        | 19-5 | SIDESTAND SWITCH .....                | 19-10 |
| HORN.....                 | 19-5 | VS SENSOR .....                       | 19-11 |
| COMBINATION METER.....    | 19-6 | TURN SIGNAL RELAY .....               | 19-11 |

## LIGHTS/METERS/SWITCHES

# SERVICE INFORMATION

### GENERAL

- Be sure to install the dust cover after replacing the bulb.
- Check the battery condition before performing any inspection that requires proper battery voltage.
- A continuity test can be made with the switches installed on the motorcycle.
- The following color codes are used throughout this section.

|            |                 |                  |            |
|------------|-----------------|------------------|------------|
| Bu = Blue  | G = Green       | Lg = Light green | R = Red    |
| Bl = Black | Gr = Gray       | O = Orange       | W = White  |
| Br = Brown | Lb = Light blue | P = Pink         | Y = Yellow |

### SPECIFICATIONS

| ITEM              |                       | SPECIFICATION  |                   |
|-------------------|-----------------------|----------------|-------------------|
| Bulbs             | Headlight (High/Low)  | 12 V - 35/35 W |                   |
|                   | Brake/tail light      | LED            |                   |
|                   | Turn signal light     | Front          | 12 V - 21/5 W x 2 |
|                   |                       | Rear           | 12 V - 21 W x 2   |
|                   | License light         | 12 V - 5 W     |                   |
|                   | Meter light           | LED            |                   |
|                   | Turn signal indicator | LED            |                   |
|                   | High beam indicator   | LED            |                   |
| Neutral indicator | LED                   |                |                   |
| Fuse              | Main fuse             | 15 A           |                   |
|                   | Sub fuse              | 10 A           |                   |

### TORQUE VALUES

#### LIGHTS/METERS/SWITCHES

| ITEM                         | Q'TY | THREAD DIA. (mm) | TORQUE N-m (kgf-m, lbf-ft) | REMARKS |
|------------------------------|------|------------------|----------------------------|---------|
| Tail light unit mounting nut | 2    | 6                | 10 (1.0, 7)                |         |
| Combination meter screw      | 8    | 3                | 1.0 (0.1, 0.7)             |         |

## SYSTEM LOCATION

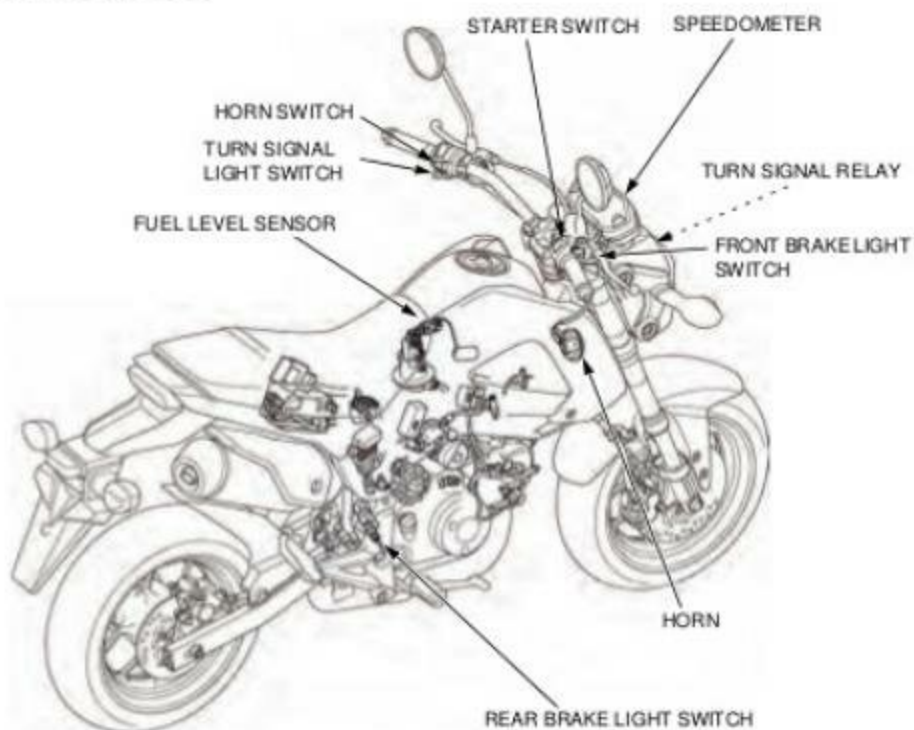

## HEADLIGHT

### HEADLIGHT BULB REPLACEMENT

Remove the headlight assembly (page 2-7).

Disconnect the headlight connector.

Remove the dust cover [1].

Unhook the bulb retainer [2] and remove the headlight bulb [3].

Remove the socket and headlight bulb [3].

#### NOTICE

- Wear clean gloves while replacing the bulb. Do not put fingerprints on the headlight bulb, as they may create hot spots on the bulb and cause it to fail.
- If you touch the bulb with your bare hands, clean it with a cloth moistened with alcohol to prevent its early failure.

Installation is in the reverse order of the removal.

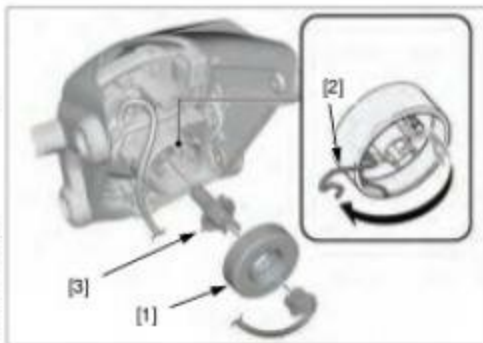

## TURN SIGNAL LIGHT

### BULB REPLACEMENT

Remove the screw [1] and turn signal light lens [2] by releasing its tab.

While pushing in the bulb [3], turn it counterclockwise to remove it.

Installation is in the reverse order of removal.



## BRAKE/TAILLIGHT

### REMOVAL/INSTALLATION

Remove the body cover (page 2-6).

Disconnect the brake/taillight connector and release the wire from the clamps.

Remove the two nuts [1], washers [2] and brake/taillight unit [3] by releasing its boss from the grommet of the rear fender.

Installation is in the reverse order of removal.

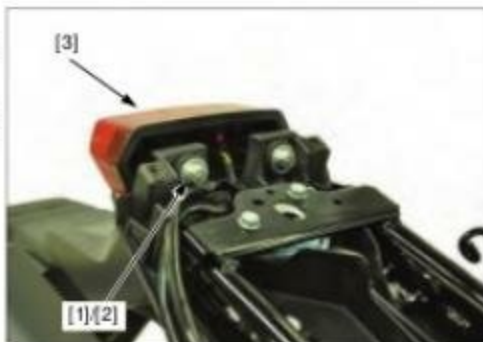

**LICENSE LIGHT****BULB REPLACEMENT**

Remove the two screws [1], license light lens [2] and bulb [3].

Install a new bulb in the reverse order of removal.

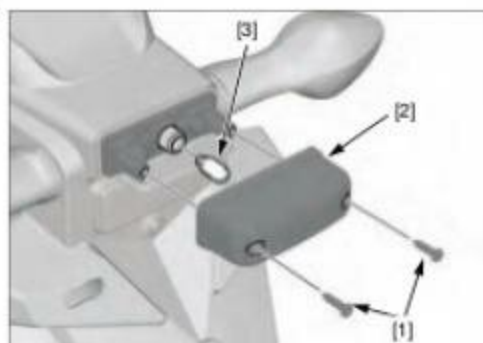
**HORN****INSPECTION**

Disconnect the horn wire connectors [1].  
Connect the 12 V battery to the horn terminals.

The horn is normal if it sounds when the 12 V battery is connected to the horn terminals.

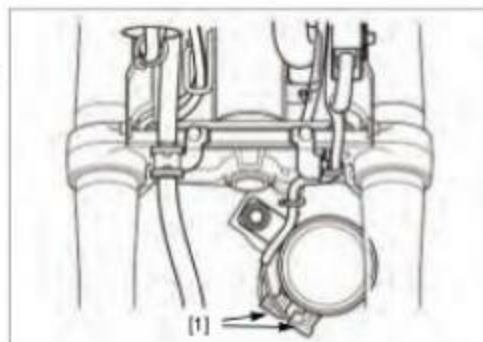
**REMOVAL/INSTALLATION**

Disconnect the horn wire connectors [1].

Remove the following:

- Bolt [2]
- Horn

Installation is in the reverse order of removal.

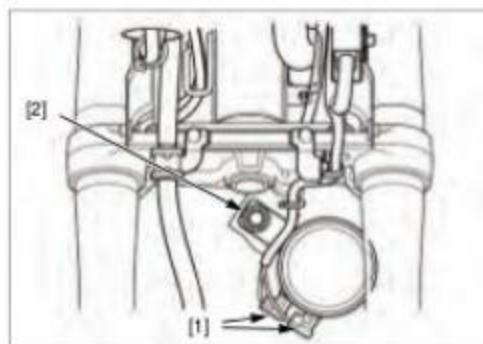

## COMBINATION METER

### REMOVAL/INSTALLATION

Remove the headlight assembly (page 2-7):

Remove the three screws [1] and combination meter.

Disconnect the meter connector [2].

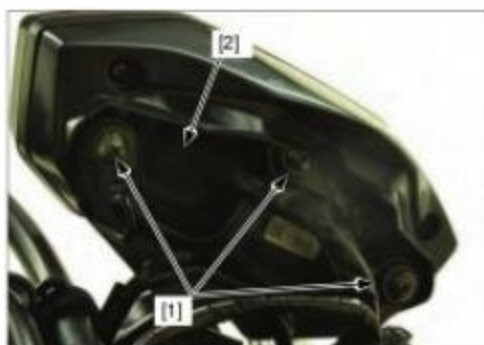

### DISASSEMBLY/ASSEMBLY

Remove the combination meter screw then, disassemble the combination meter.

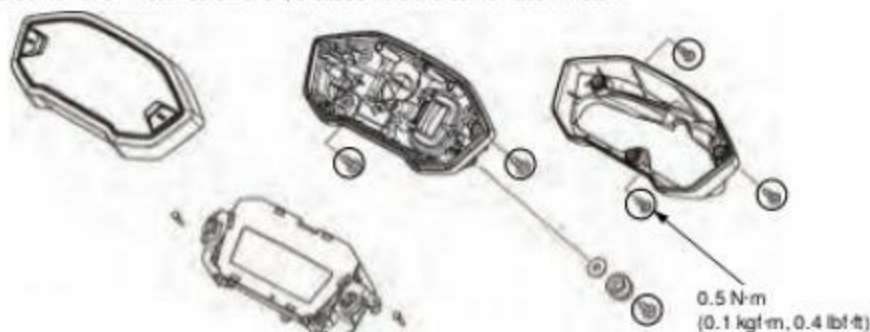

### DIGITAL CLOCK SET PROCEDURE

1. Turn the ignition switch on.
2. Press and hold the SEL [1] and SET [2] buttons until the hour digits [3] start blinking.
3. Press the SEL button until the desired hour is displayed.
4. Press and hold to advance the hour fast.
5. Press the SET button. The minute digits start blinking.
6. Press the SEL button until the desired minute is displayed.
7. Press and hold to advance the minute fast.
8. Press the SET button. The clock is set.

**NOTE:**

- The adjustment can also be set by turning the ignition switch off.
- If the SET button was not pressed during the adjustment, and no buttons were pressed for about 30 seconds, the display will stop blinking automatically and the adjustment will be cancelled.



**FUEL GAUGE/FUEL LEVEL SENSOR****FUEL LEVEL SENSOR REMOVAL/  
INSTALLATION**

Remove the fuel pump unit.

Disconnect the fuel level sensor Red [1] and Black [2] wire connectors.

Release the wires from the guides [3] of the fuel pump unit.

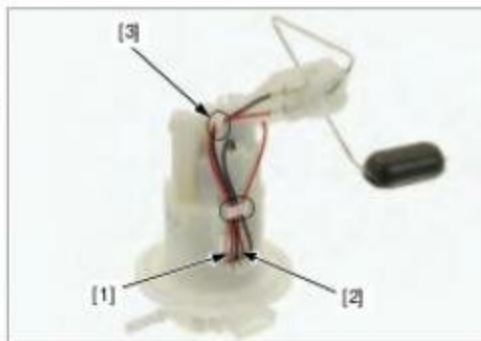

Remove the fuel level sensor [1] from the fuel pump unit by releasing the three hooks [2].

Installation is in the reverse order of removal.

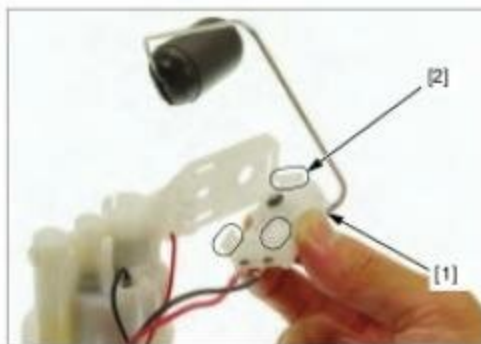
**FUEL LEVEL SENSOR INSPECTION**

Remove the fuel level sensor.

Connect the ohmmeter to the fuel level sensor wire terminals.

Inspect the resistance of the float at the full and empty positions.

|                 |                 |                    |
|-----------------|-----------------|--------------------|
| Float position: | FULL            | EMPTY              |
| Resistance:     | 6 - 10 $\Omega$ | 266 - 274 $\Omega$ |

Replace the fuel level sensor if it is out of specification.

Install the fuel level sensor.

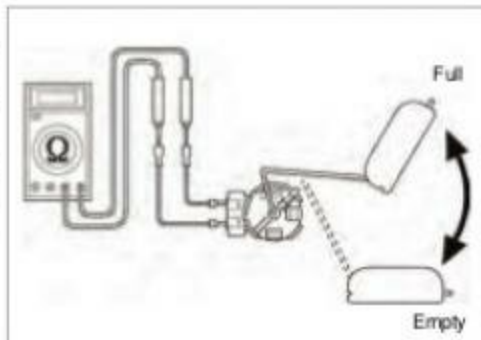

## IGNITION SWITCH

## INSPECTION

Remove the headlight assembly.

Turn the ignition switch "OFF".

Disconnect the ignition switch connector 4P [1].

Check for continuity between the switch side connector terminals in each switch position according to the chart (page 20-2).

Connect the ignition switch connector 4P [1].

Install the headlight assembly.

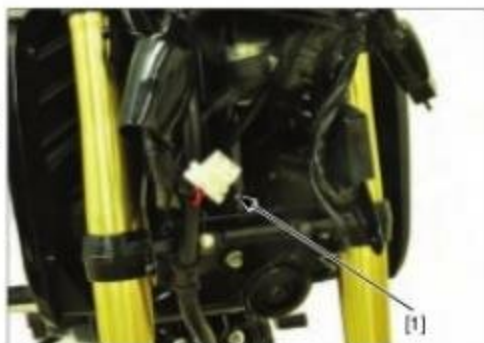

## REMOVAL/INSTALLATION

Remove the headlight assembly (page 2-7).

Disconnect the ignition switch connector [1].



Loosen the top bridge pinch bolts [1].

Remove the steering stem nut [2], washer [3] and top bridge.

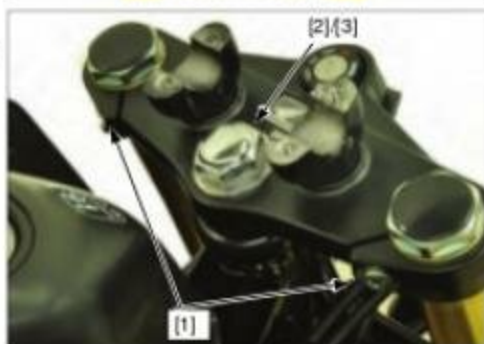

Remove the screw [1] and ignition switch [2].

Install the ignition switch and tighten the new screw.

Installation is in the reverse order of removal.

## TORQUE:

Steering stem nut: 88 N·m (9.0 kgf·m, 65 lbf·ft)

Top bridge pinch bolt: 27 N·m (2.8 kgf·m, 20 lbf·ft)



## HANDLEBAR SWITCHES

### RIGHT HANDLEBAR SWITCH

Check for continuity between the switch side connector terminals in each switch position.

Continuity should exist between the color coded wire as shown in the wiring diagram.

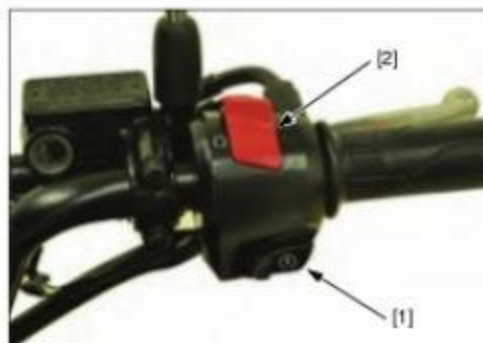

### LEFT HANDLEBAR SWITCH

Check for continuity between the switch side connector terminals in each switch position.

Continuity should exist between the color coded wire as shown in the wiring diagram.

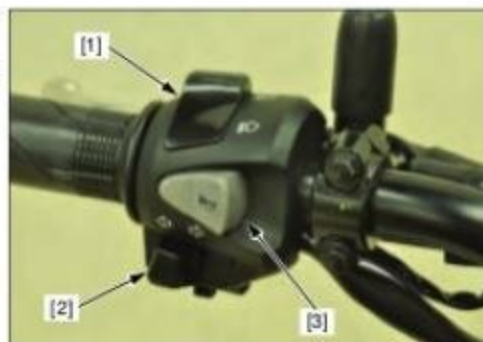

## BRAKE LIGHT SWITCH

### FRONT

Disconnect the front brake light switch wire connectors and check for continuity between the switch terminals [1].

There should be continuity with the brake lever squeezed and no continuity with the lever released.



## LIGHTS/METERS/SWITCHES

### REAR

Disconnect the rear brake light switch wire connectors [1].

Check for continuity between the switch side connector terminals.

There should be continuity with the brake pedal applied and no continuity with the pedal released.

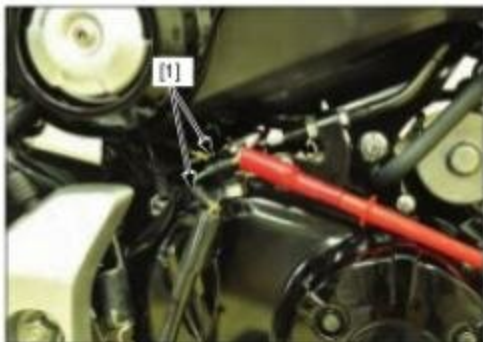

### NEUTRAL SWITCH

#### INSPECTION

Check the operation of neutral indicator at each gear position.

If the indicator bulbs are normal check as follows:

Disconnect the neutral switch connector [1].

Check the continuity between the neutral switch connector and ground.

There should be continuity with the gear is neutral and no continuity with the any gear position.

#### REMOVAL/INSTALLATION

Remove the bolt, spring cap, and neutral switch.

Installation is the reverse of removal.

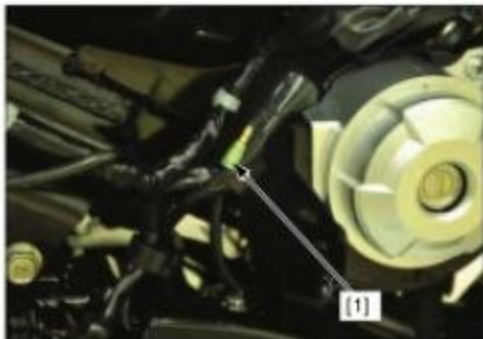

### SIDESTAND SWITCH

#### INSPECTION

Disconnect the sidestand switch 3P connector.

Check the continuity at the sidestand 3P connector of the switch side connector.

There should be continuity with the sidestand retracted and no continuity with the sidestand lowered.

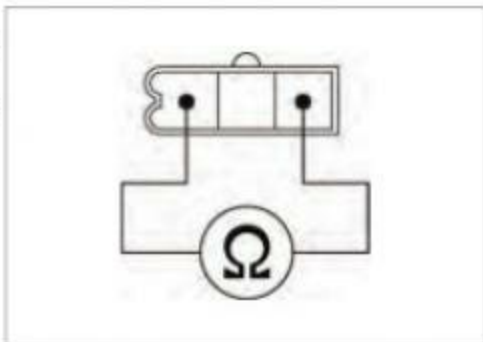

**REMOVAL/INSTALLATION**

Remove the bolt [1] and sidestand switch [2].  
Install the sidestand switch and tighten the new bolt.

**TORQUE:**

**Sidestand switch bolt: 10 N·m (1.0 kgf·m, 7 lbf·ft)**

**NOTE:**

Align the sidestand switch groove with the frame pin.

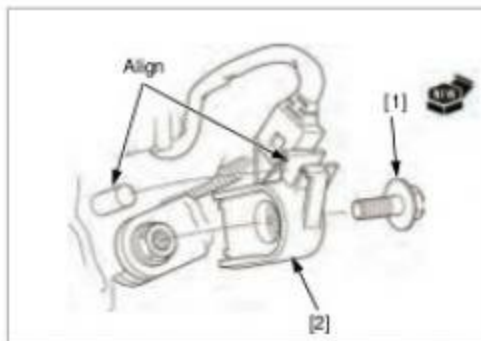
**VS SENSOR**

Check for loose or poor contact of the VS sensor connector.

Disconnect the VS sensor connector.

Turn the ignition switch ON and engine stop switch "OFF".

Measure the voltage between the VS sensor terminals at the wire side.

**CONNECTION:** Pink (+) - Green (-)

**STANDARD:** Battery voltage

If the battery voltage appears, replace the VS sensor.

If there is no voltage, check the following:

- Pink wire open circuit
- Green wire open circuit
- Combination meter

**TURN SIGNAL RELAY****INSPECTION**

Check the following:

- Battery condition
- Ignition switch and turn signal light switch function
- Loose connectors
- Fuse

If above items are all normal, check the following:

Remove the headlight assembly (page 2-7).

Disconnect the turn signal relay 2P connector [1].

Remove the turn signal relay [2] from the speedometer.

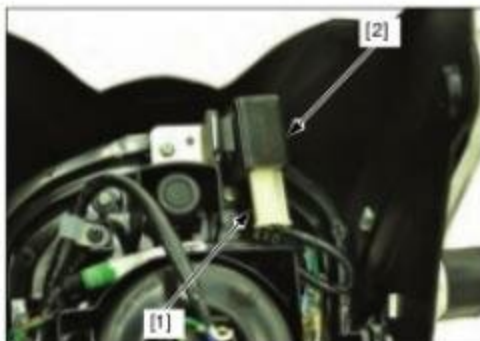

## LIGHTS/METERS/SWITCHES

Short the Black and Gray terminals of the harness side 2P connector [1] with the jumper wire.

Turn the ignition switch ON.

Check the turn signal light by moving the turn signal light switch [2] to the right and left.

- If the turn signal light does not come on, there is open circuit in wire harness.
- If the lights come on, the circuit is normal.  
Replace the turn signal relay.

Install the removed parts in the reverse order of removal.

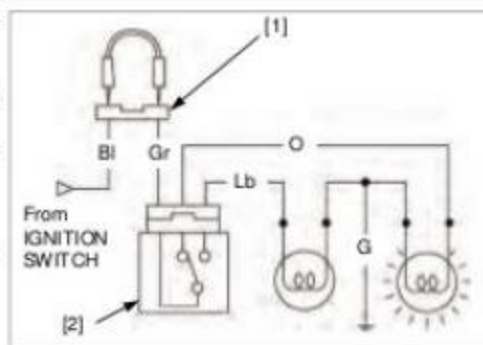

## 2. BODY PANELS/EXHAUST SYSTEM

---

|                             |     |  |      |
|-----------------------------|-----|--|------|
| SERVICE INFORMATION .....   | 2-2 | HEADLIGHT .....                          | 2-7  |
| TROUBLESHOOTING .....       | 2-2 | REAR INNER FENDER .....                  | 2-7  |
| FRONT FENDER .....          | 2-3 | REAR FENDER A/<br>REAR FENDER STAY ..... | 2-8  |
| SEAT .....                  | 2-3 | REAR FENDER B .....                      | 2-9  |
| SHROUD .....                | 2-4 | DRIVE CHAIN COVER .....                  | 2-9  |
| BODY COVER/TAIL COVER ..... | 2-6 | EXHAUST PIPE/MUFFLER .....               | 2-10 |
| FUEL TANK COVER .....       | 2-6 |  |      |

## BODY PANELS/EXHAUST SYSTEM

### SERVICE INFORMATION

#### GENERAL

- Serious burns may result if the exhaust system is not allowed to cool before components are removed or serviced.
- When installing the exhaust system, loosely install all of the exhaust pipe fasteners. Always tighten the exhaust pipe joint nuts first, then tighten the mounting bolt and nut.
- Always inspect the exhaust system for leaks after installation.

#### TORQUE VALUES

##### BODY PANELS/EXHAUST SYSTEM

| ITEM                                    | Q'TY | THREAD DIA. (mm) | TORQUE N·m (kgf·m, lbf·ft) | REMARKS                            |
|---|------|------------------|----------------------------|------------------------------------|
| Body cover and tailcover mounting screw | 4    | 4                | 0.9 (0.1, 0.7)             |                                    |
| Exhaust pipe cover bolt                 | 2    | 6                | 14 (1.4, 10)               |                                    |
| Exhaust pipe mounting nut               | 2    | 8                | 27 (2.8, 20)               |                                    |
| Exhaust pipe mounting bolt              | 1    | 8                | 27 (2.8, 20)               |                                    |
| Exhaust pipe stud bolt                  | 2    | 8                | -                          | See page 2-10                      |
| Front fender mounting bolt              | 6    | 6                | 12 (1.2, 9)                |                                    |
| Front cowl mounting bolt                | 4    | 6                | 12 (1.2, 9)                |                                    |
| Muffler band bolt                       | 1    | 8                | 20 (2.0, 15)               |                                    |
| Muffler mounting bolt                   | 1    | 8                | 27 (2.8, 20)               |                                    |
| Muffler mounting nut                    | 1    | 8                | 27 (2.8, 20)               |                                    |
| Muffler protector bolt                  | 1    | 6                | 14 (1.4, 10)               |                                    |
| Rear fender stay bolt                   | 2    | 8                | 31 (3.2, 23)               |                                    |
| Seat lock bracket bolt                  | 2    | 6                | 14 (1.4, 10)               |                                    |
| Shroud screw                            | 3    | 5                | 4.2 (0.4, 3.1)             |                                    |
| Shroud tapping screw                    | 20   | 4                | 0.9 (0.1, 0.7)             |                                    |
| Sidestand lock nut                      | 1    | 10               | 30 (3.1, 22)               | U-nut                              |
| Sidestand pivot bolt                    | 1    | 10               | 10 (1.0, 7)                |                                    |
| Sidestand switch bolt                   | 1    | 10               | 10 (1.0, 7)                | ALOC bolt; replace with a new one. |

### TROUBLESHOOTING

#### Excessive exhaust noise

- Broken exhaust system
- Exhaust gas leak

#### Poor performance

- Deformed exhaust system
- Exhaust gas leak
- Clogged muffler

**FRONT FENDER****REMOVAL/INSTALLATION**

Remove the following:

- Cap nut [1] and brake hose clamp [2]
- Bolts [3], collars [4]/[5] and grommets [6]

Remove the front fender from the fork legs.

Installation is in the reverse order of removal.

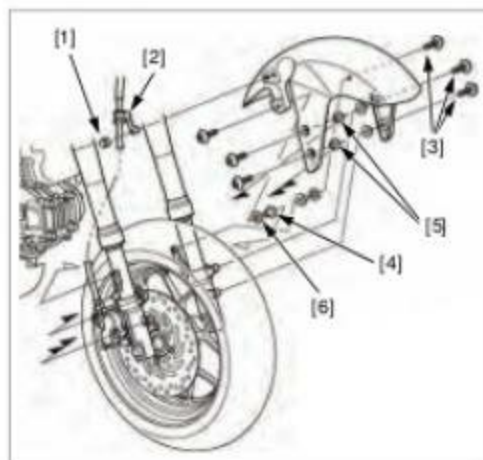

Remove the nut [1] and reflector [2].

Remove the nut [3] and reflector stay [4].

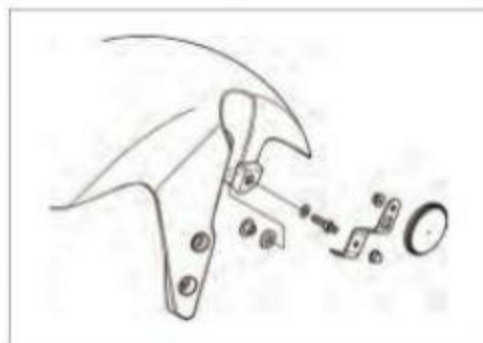
**SEAT****REMOVAL/INSTALLATION****REMOVAL**

Insert the ignition key into the seat lock.

Turn it clockwise, then pull the seat up and back.

**INSTALLATION**

Insert the prongs into the stays on the frame.

Push forward and down on the rear of the seat until it locks in place.

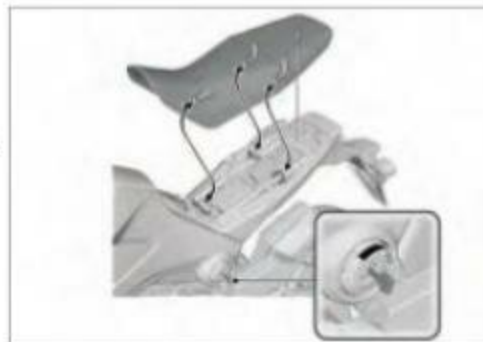

## **SHROUD**

### **REMOVAL/INSTALLATION**

Remove the seat (page 2-3).

Remove the following:

- Screws [1]/[2]
- Bolts [3]
- Trim clips [4]

Remove the snap fit clip [5].

Release the shroud bosses [6] from the air cleaner housing grommets.

Assembly is in the reverse order of disassembly.

### **TORQUE:**

**Shroud screw [1]:**

**4.2 N·m (0.4 kgf·m, 3.1 lbf·ft)**

**Shroud tapping screw [7]:**

**0.9 N·m (0.1 kgf·m, 0.7 lbf·ft)**

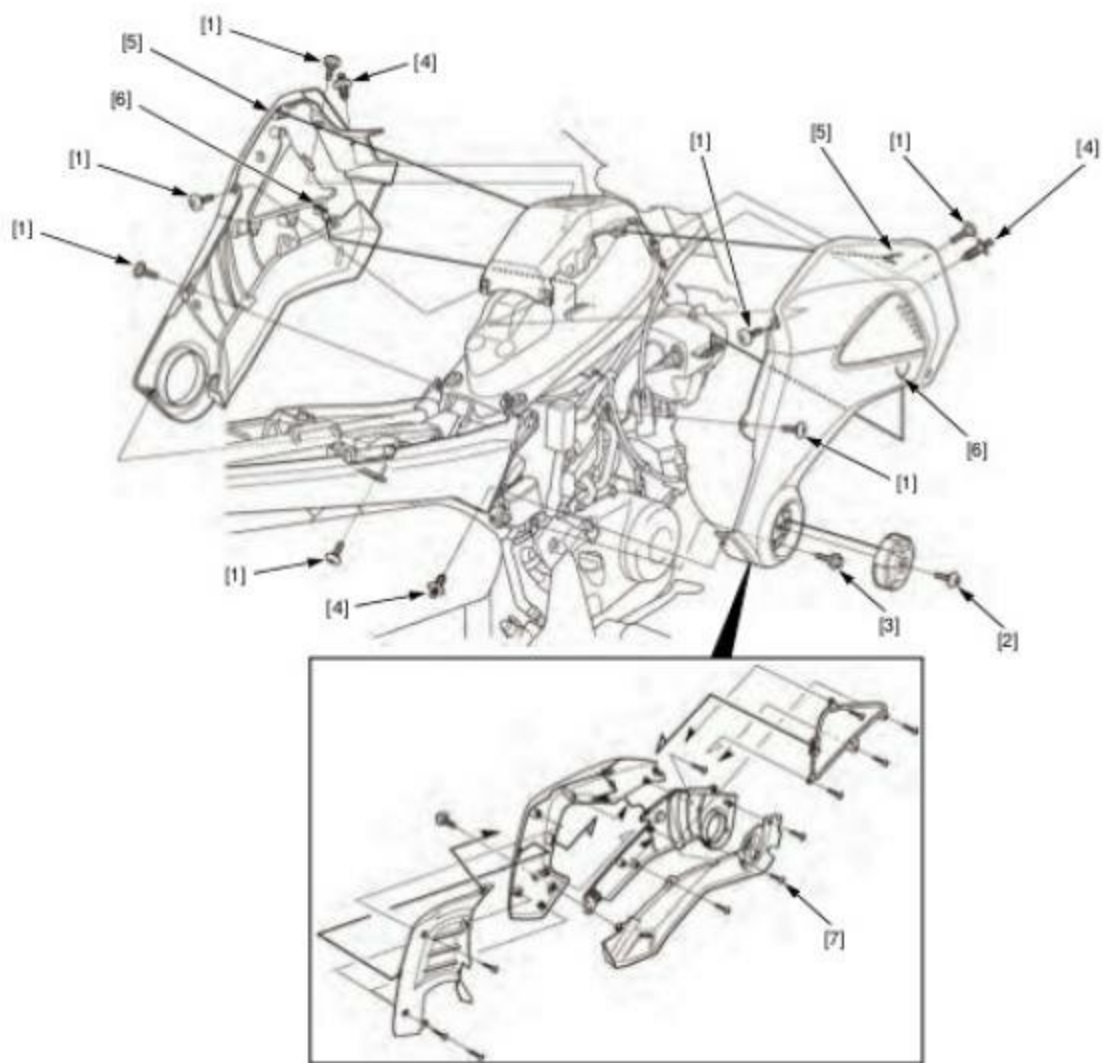

### BODY COVER/TAIL COVER

#### REMOVAL/INSTALLATION

Remove the following:

- Shroud (page 2-4)
- Bolts [1]
- Screws [2]/[3]
- Trim clips [4]
- Body cover

Remove the screws and separate the body cover and tail cover [5].

Installation is in the reverse order of removal.

#### TORQUE:

Body cover/tail cover mounting screw [2]:  
0.9 N·m (0.1 kgf·m, 0.7 lbf·ft)

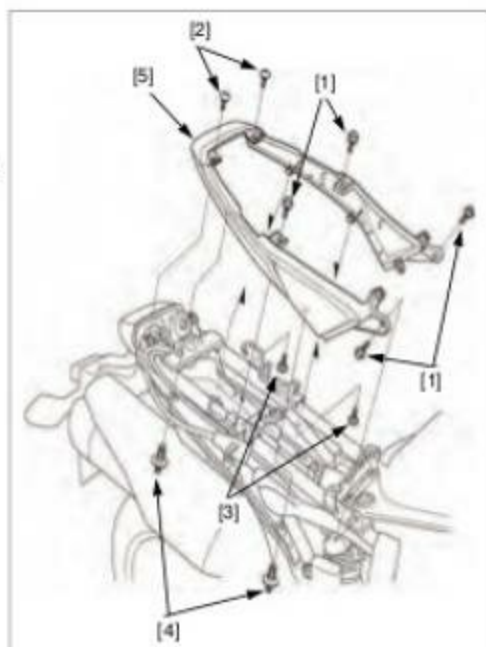

### FUEL TANK COVER

#### REMOVAL/INSTALLATION

Remove the shroud (page 2-4).

Remove the four screws [1] and fuel tank cover [2].

Installation is in the reverse order of removal.



## HEADLIGHT

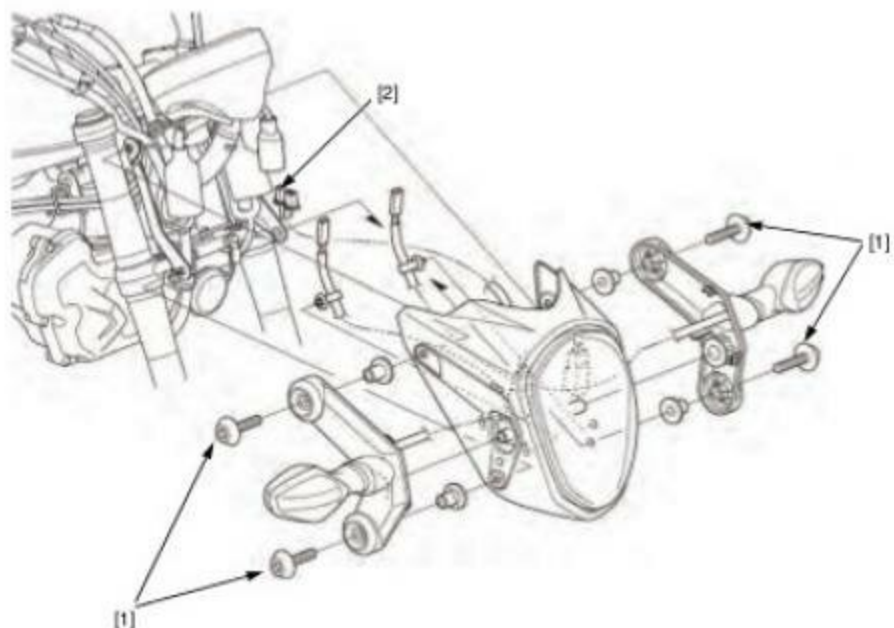

### REMOVAL/INSTALLATION

Remove the bolts [1].

Disconnect the headlight connector [2] then, remove the headlight assembly.

#### TORQUE:

Front cowl mounting screw [1]:  
12 N·m (1.2 kgf·m, 9 lbf·ft)

### DISASSEMBLY/ASSEMBLY

- Aiming adjust screw (page 3-12)
- Headlight form the headlight cover [4]
- Front turn signal light

## REAR INNER FENDER

### REMOVAL/INSTALLATION

Remove the screws [1] and rear inner fender.

Installation is in the reverse order of removal.

TORQUE: 0.9 N·m (0.1 kgf·m, 0.7 lbf·ft)

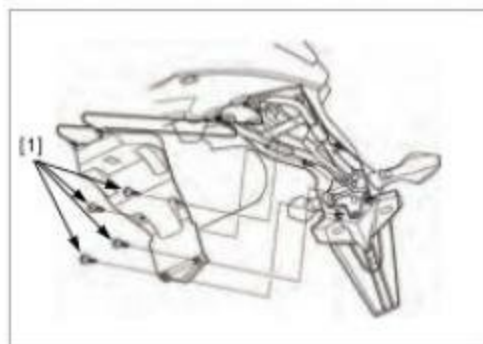

**REAR FENDER A/REAR FENDER STAY**

**REMOVAL/INSTALLATION**

Remove the following:

- Rear inner fender (page 2-7)
- Body cover (page 2-6)

Disconnect the license light wire connectors [1] and rear turn signal light connectors [2].

Remove the bolts [3], rear fender assembly.

Remove the bolts [4] and rear turn signal light.

Remove the bolt [5] then, separate the fender A [6] from the rear fender stay [7].

Installation is in the reverse order of removal.

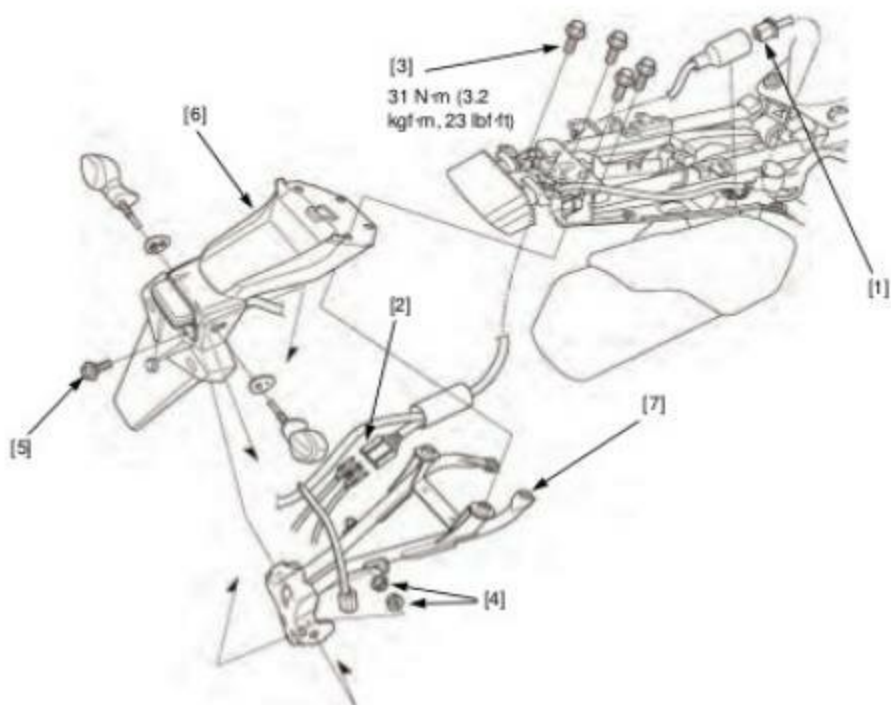

**DISASSEMBLY/ASSEMBLY**

Remove the nut [1], collar [2] and license light [3].

Remove the nut [4] and reflector [5] from the rear fender A.

Assembly is in the reverse order of disassembly.

**NOTE:**

Align the reflector tab with the hole of the rear fender A.

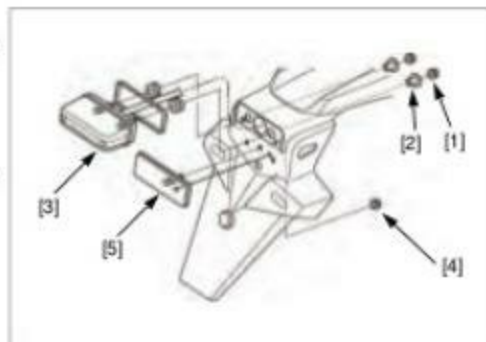

## REAR FENDER B

### REMOVAL/INSTALLATION

Remove the following:

- Battery
- Rear fender A/rear fender stay (page 2-8)

Disconnect the tail light connector [1].

Release the fuse box from the rear fender B.

Remove the battery cover by releasing the tabs from the slots of the rear fender B.

Remove the bolts and release the tab of the rear fender B from the slot of the seat lock bracket.

Remove the rear fender B by pulling it rearward.

Installation is in the reverse order of removal.

#### NOTE:

Install the rear fender B by aligning its front lower groove with the seat rail brace.

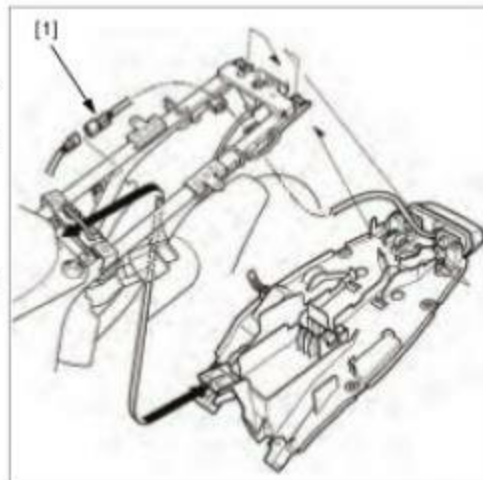

## DRIVE CHAIN COVER

### REMOVAL/INSTALLATION

Remove the bolts and drive chain cover by pulling it rearward and releasing the tabs [1] from the slots [2] on the swingarm.

Installation is in the reverse order of removal.

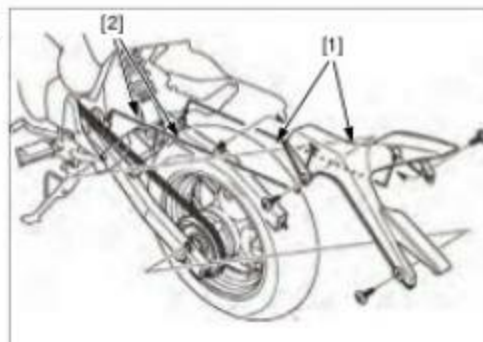

**EXHAUST PIPE/MUFFLER**

**REMOVAL/INSTALLATION**

Loosen the bolt [1].

Remove the following:

- Bolt [2]
- Nut [3]
- Muffler [4]
- Exhaust pipe mounting nut [5]
- Bolt [6]
- Exhaust pipe [7].

Installation is in the reverse order of removal.

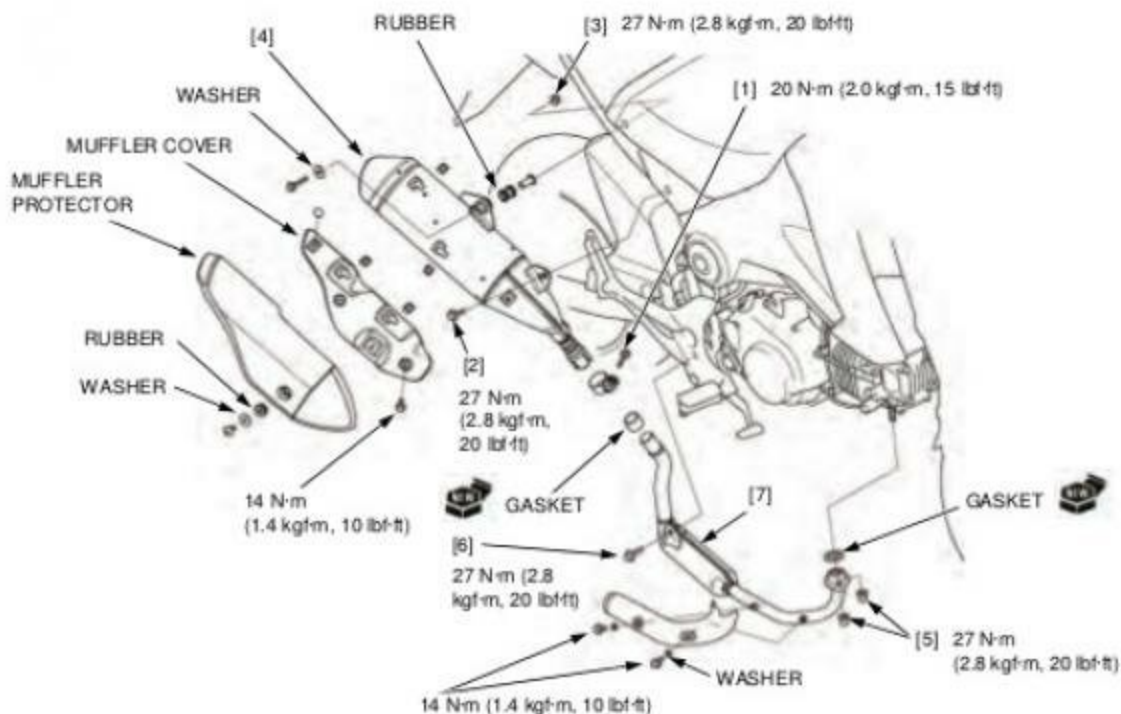

**EXHAUST PIPE STUD BOLT REPLACEMENT**

Thread two nuts to the stud bolt and tighten them together, then use a wrench on them to turn the stud bolt out.

Install and tighten new stud bolts into the cylinder head to the specified torque.

**TORQUE: 11 N·m (1.1 kgf·m, 8 lbf·ft)**

After tightening the stud bolts, check that the length from the bolt head to the cylinder head surface is within specification.

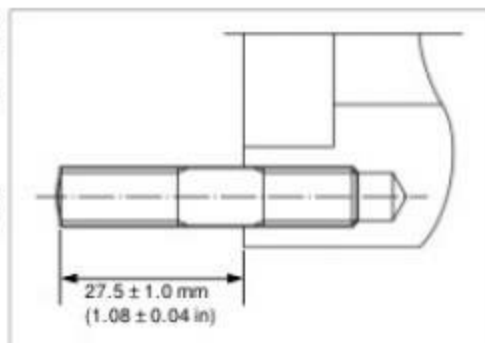

WIRING DIAGRAM.....20-2

# WIRING DIAGRAMS

## WIRING DIAGRAM

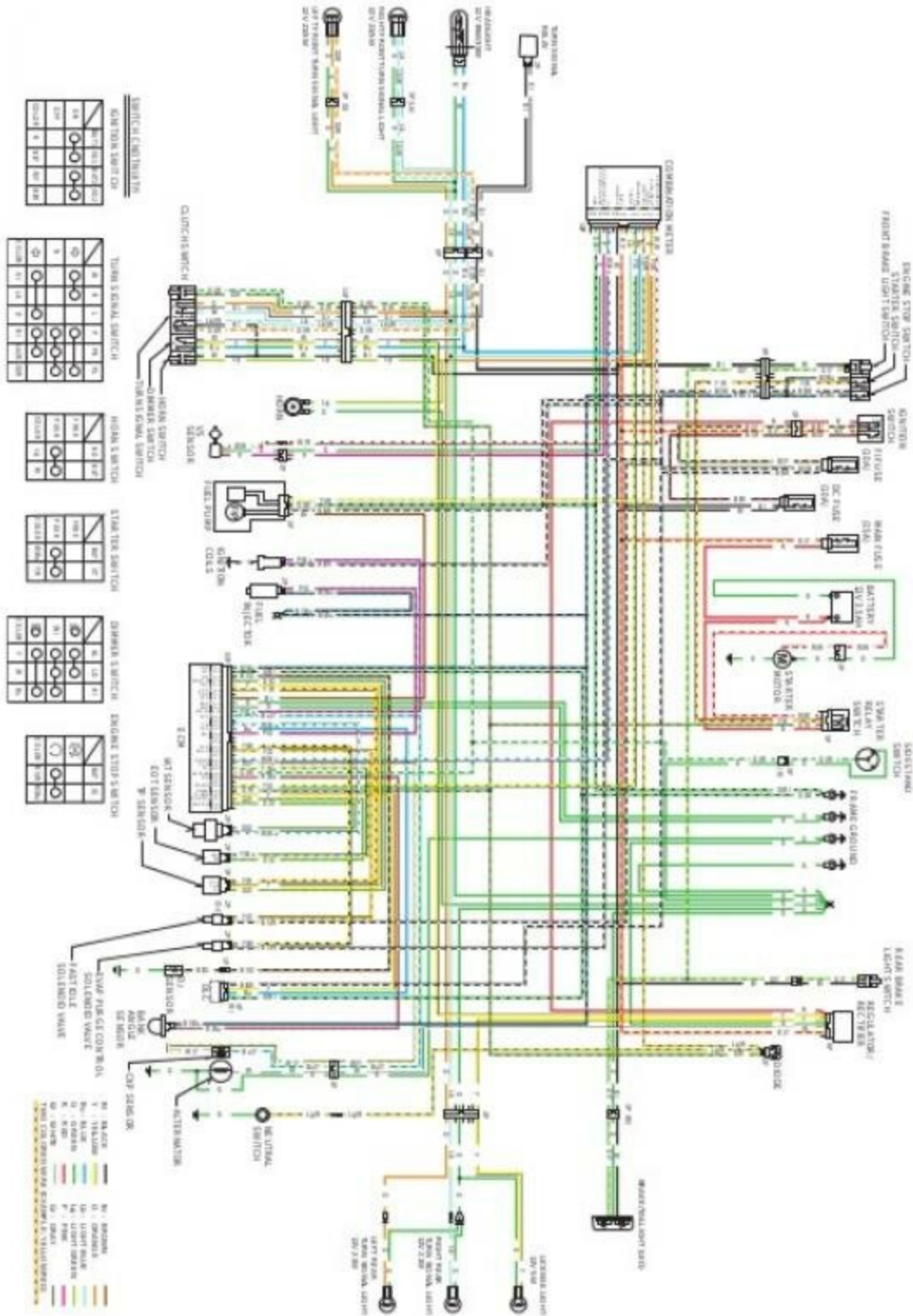

---

**MEMO**

---

---

**MEMO**

---

---

**MEMO**

---

---

**MEMO**

---

|                            |      |                              |      |
|----------------------------|------|------------------------------|------|
| SERVICE INFORMATION .....  | 3-2  | BRAKE FLUID .....            | 3-11 |
| MAINTENANCE SCHEDULE ..... | 3-3  | BRAKE SYSTEM .....           | 3-11 |
| THROTTLE OPERATION .....   | 3-4  | BRAKE LIGHT SWITCH .....     | 3-12 |
| AIR CLEANER .....          | 3-4  | HEADLIGHT AIM .....          | 3-12 |
| CRANKCASE BREATHER .....   | 3-5  | CLUTCH SYSTEM .....          | 3-12 |
| SPARK PLUG .....           | 3-5  | SIDESTAND .....              | 3-13 |
| VALVE CLEARANCE .....      | 3-6  | SUSPENSION .....             | 3-13 |
| ENGINE OIL .....           | 3-7  | NUTS, BOLTS, FASTENERS ..... | 3-14 |
| ENGINE IDLE SPEED .....    | 3-8  | WHEELS/TIRES .....           | 3-14 |
| DRIVE CHAIN .....          | 3-9  | STEERING HEAD BEARINGS ..... | 3-14 |
| BRAKE PADS WEAR .....      | 3-10 |                              |      |

## MAINTENANCE

# SERVICE INFORMATION

## GENERAL

- Place the motorcycle on a level ground before starting any work.
- Gasoline is extremely flammable and is explosive under certain conditions.
- Work in a well ventilated area. Smoking or allowing flames or sparks in the work area or where the gasoline is stored can cause a fire or explosion.
- The exhaust contains poisonous carbon monoxide gas that may cause loss of consciousness and may lead to death. Run the engine in and open area or with an exhaust evacuation system in and enclosed area.

## TORQUE VALUES

### MAINTENANCE

| ITEM                      | Q'TY | THREAD DIA. (mm) | TORQUE N-m (kgf-m, lbf-ft) | REMARKS |
|---------------------------|------|------------------|----------------------------|---------|
| Air cleaner cover screw   | 8    | 5                | 1.1 (0.1, 0.8)             |         |
| Air cleaner element screw | 1    | 5                | 1.1 (0.1, 0.8)             |         |
| Spark plug                | 1    | 10               | 16 (1.6, 12)               |         |
| Crankshaft hole cap       | 1    | 30               | 8.0 (0.8, 5.9)             |         |
| Oil drain bolt            | 1    | 12               | 24 (2.4, 18)               |         |

## TOOLS

Locknut Wrench 8 x 9 mm  
07708-0030100



Commercially available in the U.S.A.

Tappet Adjusting Wrench  
07708-0030400



07908-3290200 (U.S.A. only)

## MAINTENANCE SCHEDULE

Perform the Pre-ride inspection in the Owner's Manual at each scheduled maintenance period.

I: Inspect and Clean, Adjust, Lubricate or Replace if necessary. C: Clean. R: Replace. A: Adjust. L: Lubricate.

The following items require some mechanical knowledge. Certain items (particularly those marked \* and \*\*) may require more technical information and tools. Consult a dealer.

| ITEMS                                 | FREQUENCY<br>NOTE | ODOMETER READING (NOTE 1) |  |     |   | ANNUAL<br>CHECK | REGULAR<br>REPLACE | REFER<br>TO PAGE |     |
|---------------------------------------|-------------------|---------------------------|--|-----|---|-----------------|--------------------|------------------|-----|
|                                       |                   | x 1,000 km                | 1  | 4   | 8 |                 |                    |                  | 12  |
|                                       |                   | x 1,000 mi                | 0.6  | 2.5 | 5 |                 |                    |                  | 7.5 |
| * FUEL LINE                           |                   |                           |  |     |   |                 |                    | 7-3              |     |
| * THROTTLE OPERATION                  |                   |                           |  |     |   |                 |                    | 3-4              |     |
| * AIR CLEANER                         | NOTE 2            |                           | EVERY 10000 mi<br>(16000 km) R   |     |   |                 |                    |                  | 3-4 |
| CRANKCASE BREATHER                    | NOTE 3            |                           | C  | C   | C | C               |                    | 3-5              |     |
| SPARK PLUG                            |                   |                           |  | R   |   |                 |                    | 3-5              |     |
| * VALVE CLEARANCE                     |                   |                           |  |     |   |                 |                    | 3-6              |     |
| ENGINE OIL                            |                   |                           | INITIAL 600 mi<br>(1000 km) or<br>1 month: R<br>REGULAR EVERY<br>2500 mi (4000 km) or<br>6 months: R |     |   |                 | R                  |                  | 3-7 |
| ** ENGINE STRAINER SCREEN             |                   |                           |  |     |   | C               |                    | 8-5              |     |
| ** ENGINE OIL CENTRIFUGAL FILTER      |                   |                           |  |     |   | C               |                    | 8-5              |     |
| * ENGINE IDLE SPEED                   |                   |                           |  |     |   |                 |                    | 3-8              |     |
| * EVAPORATIVE EMISSION CONTROL SYSTEM |                   |                           |  |     |   |                 |                    |                  |     |
| DRIVE CHAIN                           |                   |                           | EVERY 300 mi<br>(500 km) I, L  |     |   |                 |                    |                  | 3-9 |
| BRAKE FLUID                           | NOTE 4            |                           |  |     |   |                 |                    | 3-11             |     |
| BRAKE PADS WEAR                       |                   |                           |  |     |   |                 |                    | 3-10             |     |
| BRAKE SYSTEM                          |                   |                           |  |     |   |                 |                    | 3-11             |     |
| BRAKE LIGHT SWITCH                    |                   |                           |  |     |   |                 |                    | 3-12             |     |
| HEADLIGHT AIM                         |                   |                           |  |     |   |                 |                    | 3-12             |     |
| CLUTCH SYSTEM                         |                   |                           |  |     |   |                 |                    | 3-12             |     |
| SIDESTAND                             |                   |                           |  |     |   |                 |                    | 3-13             |     |
| * SUSPENSION                          |                   |                           |  |     |   |                 |                    | 3-13             |     |
| * NUTS, BOLTS, FASTENERS              |                   |                           |  |     |   |                 |                    | 3-14             |     |
| ** WHEELS/TIRES                       |                   |                           |  |     |   |                 |                    | 3-14             |     |
| ** STEERING HEAD BEARINGS             |                   |                           |  |     |   |                 |                    | 3-14             |     |

\* Should be serviced by a dealer, unless the owner has proper tools and service data and is mechanically qualified.

\*\* In the interest of safety, we recommend these items be serviced only by a dealer.

Honda recommends that a dealer should road test your motorcycle after each periodic maintenance is carried out.

### NOTES:

- At higher odometer readings, repeat at the frequency interval established here.
- Service more frequently when riding in unusually wet or dusty areas.
- Service more frequently when riding in rain or at full throttle.
- Replacement requires mechanical skill.

**THROTTLE OPERATION****INSPECTION**

Check for any deterioration or damage to the throttle cable. Check the throttle grip for smooth operation. Check that the throttle opens and automatically closes in all steering positions.

If the throttle grip does not return properly, overhaul and lubricate the throttle grip housing.

If the throttle grip still does not return properly, replace the throttle cable.

With the engine idling, turn the handlebar all the way to the right and left to ensure that the idle speed does not change. If idle speed increases, check the throttle grip freeplay and throttle cable connection.

Measure the throttle grip freeplay at the grip flange.

**FREPLAY:** 2 – 6 mm (0.08 - 0.24 in)

If the freeplay is out of specification, adjust as follows.

**ADJUSTMENT**

Remove the right shroud (page 2-4).

Remove the bolt [1] and throttle drum cover [2]

Loosen the lock nut [3], turn the adjuster [4] as required and tighten the lock nut while holding the adjuster.

Recheck the throttle operation and replace any damaged parts, if necessary.

Installation is in the reverse order of removal.

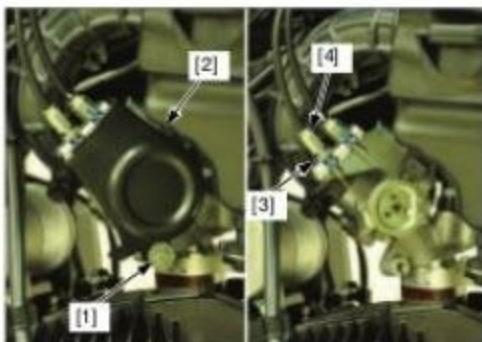
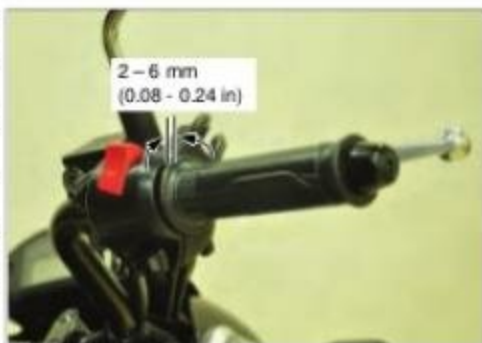
**AIR CLEANER****REMOVAL/INSTALLATION**

Remove the eight screws and air cleaner housing cover [1].

Remove screw and air cleaner element.

Discard the air cleaner element in accordance with the maintenance schedule (page 3-3).

Replace the element if it is excessively dirty or damaged.

Install the removed parts in the reverse order of removal.

**TORQUE:** Air cleaner housing cover screw  
1.1 N·m (0.1 kgf·m, 0.8 lbf·ft)

*Make sure the seals are properly positioned in the grooves on the air cleaner housing and cover.*



## CRANKCASE BREATHER

### NOTE:

Service more frequently when ridden in rain, at full throttle, or after the motorcycle is washed. Service if the deposit level can be seen in the drain cap.

Remove the shroud (page 2-4).

Check the crankcase breather hose for deterioration, damage or leakage.

Install the removed parts in the reverse order of removal.

## SPARK PLUG

### INSPECTION

Disconnect the spark plug cap.

Remove the spark plug [1].

*Clean around the spark plug base with compressed air before removing the plug and make sure no debris enters the combustion chamber.*

Inspect or replace as described in the maintenance schedule (page 3-3).

Clean the spark plug electrodes with a wire brush or special plug cleaner.

Check the insulator for cracks or damage, and the electrodes for wear, fouling or discoloration.

**RECOMMENDED SPARK PLUG:**  
**STANDARD: CPR6EA-9 (NGK)**  
**U20EPR9 (DENSO)**

Measure the spark gap between the center and side electrodes with a feeler gauge.

**SPARK PLUG GAP: 0.8 – 0.9 mm (0.03 - 0.04 in)**

If necessary, adjust the gap by bending the side electrode carefully.

Install and hand tighten the spark plug to the cylinder head, then tighten the spark plug to the specified torque.

**TORQUE: 16 N·m (1.6 kgf·m, 12 lbf·ft)**

Connect the spark plug cap.

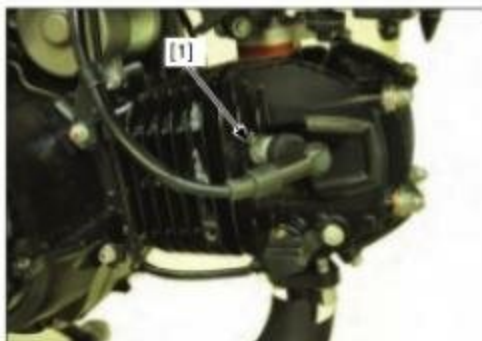

## VALVE CLEARANCE

**NOTE:**

- Inspect and adjust the valve clearance while the engine is cold (below 35°C/95°F).

**INSPECTION**

Remove the bolts [1], valve adjusting hole caps and O-rings.



Remove the crankshaft hole cap and timing hole cap from the left crankcase cover.

Rotate the crankshaft counterclockwise until the "T" mark [1] on the flywheel is aligned with the index notch [2] on the left crankcase cover.

Make sure that the piston is at TDC (Top Dead Center) on the compression stroke.

This position can be obtained by confirming that there is slack in the rocker arms. If there is no slack, turn the crankshaft again until the correct position is obtained.

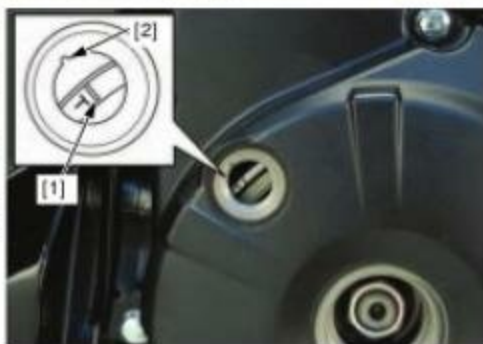

Check each valve clearance by inserting a feeler gauge [1] between the valve adjusting screw and valve stem.

**VALVE CLEARANCE:**

**IN:** 0.10 ± 0.02 mm (0.004 ± 0.001 in)

**EX:** 0.17 ± 0.02 mm (0.007 ± 0.001 in)

**ADJUSTMENT**

Adjust by loosening the lock nut and turning the adjusting screw until there is a slight drag on a feeler gauge.

**TOOLS:**

Valve adjusting wrench

07708-0030400 or  
07908-3290200  
(U.S.A. only)

Lock nut wrench, 8 x 9

07708-0030100  
Commercially  
available in the  
U.S.A.

Apply engine oil to the lock nut.

Hold the adjusting screw and tighten the lock nut to the specified torque.

**TORQUE: 9.0 N·m (0.9 kgf·m, 6.6 lbf·ft)**

Recheck the valve clearance.



Apply engine oil to a new crankshaft hole cap O-ring and timing hole cap O-ring, then install them to the caps.

Install and tighten the crankshaft hole cap and timing hole cap to the specified torque.

**TORQUE:**

**Crankshaft hole cap** 8.0 N·m (0.8 kgf·m, 5.9 lbf·ft)

**Timing hole cap** 6.0 N·m (0.6 kgf·m, 4.4 lbf·ft)

Install the new O-ring into grooves of the valve adjusting hole caps.

Install the valve adjusting hole caps to the cylinder head and tighten the bolts.

**ENGINE OIL****OIL LEVEL INSPECTION**

Start the engine and let it idle for 3 – 5 minutes.

Stop the engine and wait 2 – 3 minutes.

Hold the motorcycle in an upright position.

Remove the oil filler cap/dipstick [1] and wipe oil from the dipstick with a clean cloth.

Insert the oil filler cap/dipstick without screwing it in, remove it and check the oil level.

If the level is below or near the lower level line [2] on the dipstick, add the recommended oil to the upper level line [3].

**RECOMMENDED ENGINE OIL:**

**Pro Honda GN4 4-stroke oil (U.S.A. & Canada) or equivalent motorcycle oil**

**API service classification: SG or higher (except oils labeled as energy conserving on the circular API service label)**

**JASO T903 standard: MA**

**Viscosity: SAE 10W-30**

Install the oil filler cap/dipstick.

**ENGINE OIL CHANGE**

Warm up the engine.

Stop the engine, remove the oil filler cap/dipstick and wipe oil from the dipstick with a clean cloth.

Remove the drain bolt [1] and sealing washer [2].

Drain oil completely.

Install the oil drain bolt with a new sealing washer and tighten it to the specified torque.

**TORQUE: 24 N·m (2.4 kgf·m, 18 lbf·ft)**

Fill the engine with recommended engine oil.

**ENGINE OIL CAPACITY:**

**0.9 liter (0.96 US Qt, 0.20 Imp gal) at draining**

**1.1 liters (1.16 US Qt, 0.24 Imp gal) at disassembly**

Check that the O-ring on the oil filler cap is in good condition, and replace it if necessary.

Install the oil filler cap/dipstick.

Make sure there are no oil leaks.

Check the engine oil level (page 3-7).

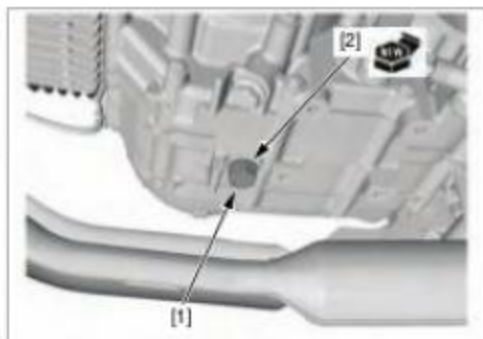
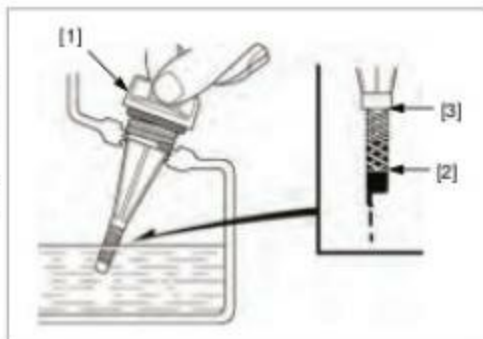

## ENGINE IDLE SPEED

### NOTICE

Failure to properly follow instructions can cause the rough idling or the engine stall.

- Before checking the engine idle speed, inspect following items.
  - No MIL blinking
  - Spark plug condition (page 3-5)
  - Air cleaner condition (page 3-4)
- Inspect and adjust the engine idle speed after all other engine maintenance items have been performed and are within specifications.
- Use a tachometer with graduations of 50 min<sup>-1</sup> (rpm) or smaller that will accurately indicate a 50 min<sup>-1</sup> (rpm) change.

Start the engine and let it idle 20 minutes.  
Check the engine idle speed.

**ENGINE IDLE SPEED: 1,400 ± 100 min<sup>-1</sup> (rpm)**

If adjustment is necessary, turn the idle air screw [1] to obtain the specified engine idle speed.

#### NOTE:

- The idle air screw can be turned up to a 1/4 rotation per turn. Leave the engine idling for 10 seconds or more to confirm the idle speed after adjustment.
- If the idling speed is still not in the specified engine idle speed, repeat the steps above.

**IDLE AIR SCREW STANDARD OPENING:**  
2 turns out from the fully seated position



## DRIVE CHAIN

### ⚠ WARNING

Never inspect and adjust the drive chain while the engine is running.

### INSPECTION

#### DRIVE CHAIN SLACK INSPECTION

Support the motorcycle with its sidestand and shift the transmission into neutral.

Measure the drive chain slack, on the chain run midway between the sprockets.

**CHAIN SLACK: 30 – 40 mm (1.2 – 1.6 in)**

### NOTICE

Excessive chain slack, 50 mm or more, may damage the frame.

#### CLEANING, LUBRICATION AND INSPECTION

Clean the chain with non-flammable or high flash point solvent [1] and wipe it dry.

Be sure the chain has dried completely before lubricating.

Inspect the drive chain for possible damage or wear.

Replace any chain that has damaged rollers, loose fitting links, or otherwise appears unserviceable.

Installing a new chain on badly worn sprockets will cause the new chain to wear quickly.

Inspect and replace the sprocket as necessary.

Lubricate the drive chain with #80 – 90 gear oil or drive chain lubricant. Wipe off any excess oil or chain lubricant.

Measure the distance between a span of 41 pins (40 links) from pin center to pin center by holding so that all links are straight.

**DRIVE CHAIN LENGTH (41 pins/40 links)**

**SERVICE LIMIT: 518 mm (20.4 in)**

#### SPROCKET INSPECTION

Inspect the drive and driven sprocket teeth for wear or damage, replace them if necessary.

Never use a new drive chain on worn sprockets.

Both chain and sprockets must be in good condition, or the new replacement chain will wear rapidly.

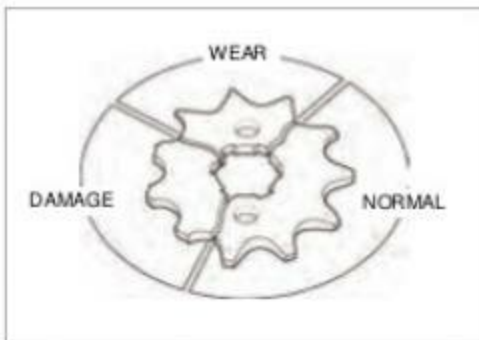
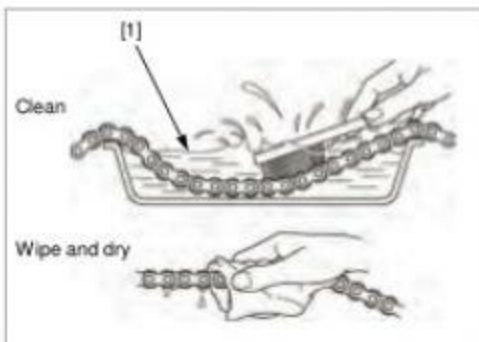

## MAINTENANCE

### ADJUSTMENT

Loosen the rear axle nut [1] and both lock nuts [2].

Turn both drive chain adjusting nuts [3] until the correct drive chain slack is obtained.

Make sure the same index lines of both adjusters are aligned with the hole ends on the swingarm.

Tighten the rear axle nut [1] to the specified torque.

**TORQUE: 59 N·m (6.0 kgf·m, 44 lbf·ft)**

Tighten the both drive chain adjusting nuts [3] and lock nuts [2] securely.

Recheck the drive chain slack and free wheel rotation.

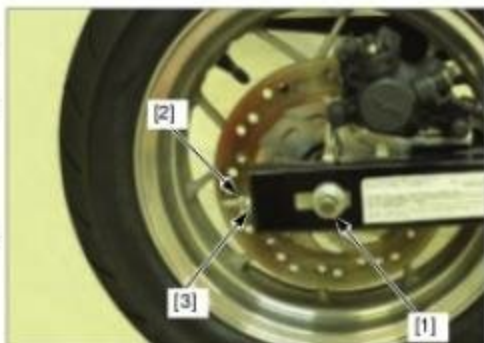

### REMOVAL/INSTALLATION

Support the motorcycle with its sidestand and shift the transmission into neutral.

If the drive chain becomes extremely dirty, it should be removed and cleaned prior to lubrication.

Remove the left crankcase rear cover.

Carefully remove the retaining clip [1] with pliers. Remove the master link [2] and link plate [3], and disconnect the drive chain.

Remove the drive chain.

Install in reverse order of removal.

Adjust the drive chain slack (page 3-10).

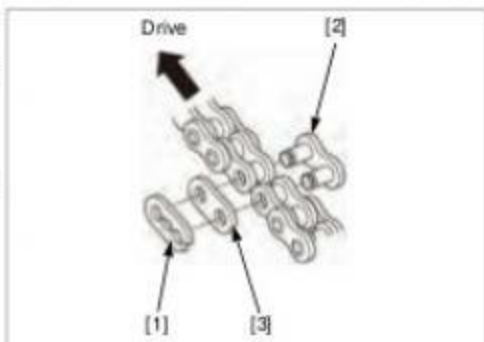

## BRAKE PADS WEAR

Check the brake pads for wear.

Replace the brake pads if either pad is worn to the wear limit groove [1].

*Always replace the brake pads as a set to assure even disc pressure.*

For front brake pad replacement (page 17-7).

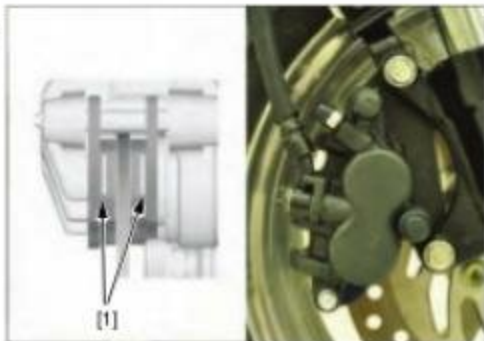

## BRAKE FLUID

### NOTICE

Spilled fluid can damage painted, plastic or rubber parts. Place a rag over these parts whenever the system is serviced.

#### NOTE:

- Do not mix different types of fluid, as they are not compatible with each other.
- Do not allow foreign material to enter the system when filling the reservoir.

Check the front and rear brake fluid level.

If the level is near the lower level line [1], check the brake pad wear (page 3-10).

A low fluid level may be due to wear of the brake pads. If the brake pads are worn the caliper pistons are pushed out, and this accounts for a low reservoir level. If the brake pads are not worn and the fluid level is low, check the entire system for leaks (page 3-11).

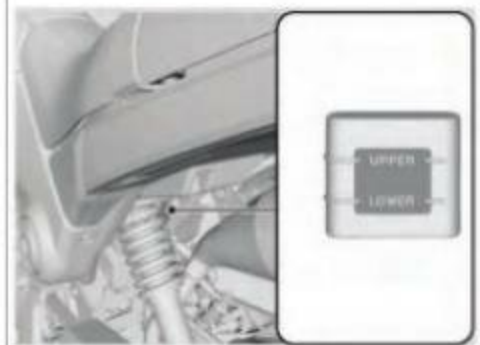
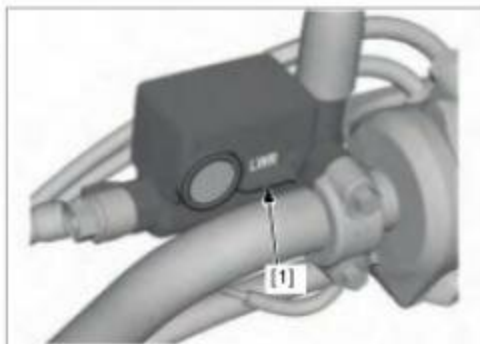

## BRAKE SYSTEM

### BRAKE INSPECTION

Firmly apply the brake lever and pedal check that no air has entered the system.

If the lever feels soft or spongy when operated, bleed the air from the system.

Inspect the brake hose [1] and fittings for deterioration, cracks and signs of leakage.

Tighten any loose fittings.

Replace hoses and fittings as required.

### BRAKE PEDAL HEIGHT ADJUSTMENT

Measure the rear brake pedal free-play (page 17-10).

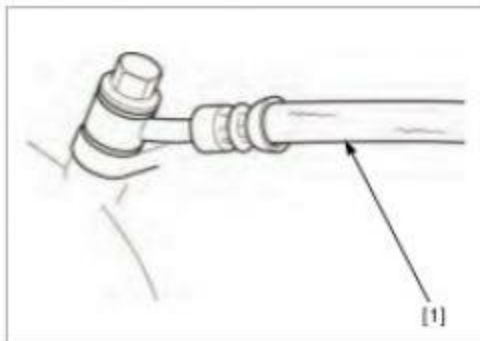

## MAINTENANCE

### BRAKE LIGHT SWITCH

#### NOTE:

- The front brake light switch cannot be adjusted. If the front brake light switch actuation and brake engagement are not synchronized, either replace the switch unit or the malfunctioning parts of the system.

Check that the brake light comes on just prior to the brake actually being engaged.

*Hold the switch body and turn the adjusting nut. Do not turn the switch body while turning the adjusting nut.*

If the light fails to come on, adjust the switch [1] by turning the adjusting nut [2] so that the light comes on at the proper time.

Recheck the brake light switch operation.

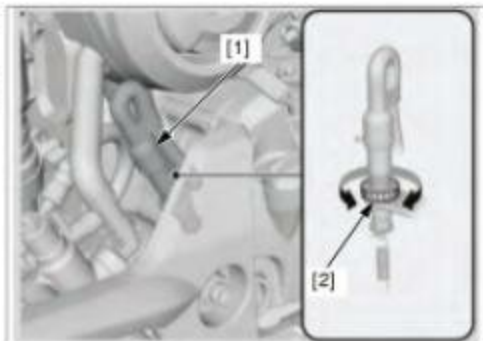

### HEADLIGHT AIM

Place the motorcycle on a level surface.

*Adjust the headlight beam as specified by local laws and regulations.*

Adjust the headlight beam vertically by loosening the bolt [1] and moving the headlight unit, then tighten the bolt.



### CLUTCH SYSTEM

Measure the clutch lever freeplay at the end of the clutch lever.

**FREEPLAY: 10 – 20 mm (0.4 - 0.8 in)**

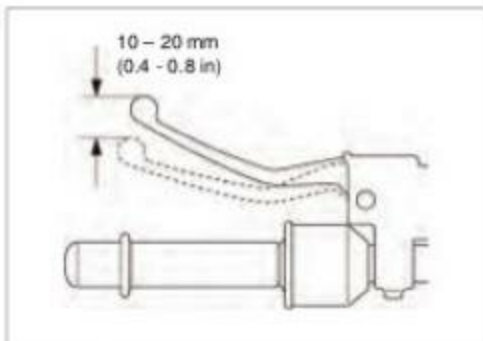

*The adjuster may be damaged if it is positioned too far out, leaving minimal thread engagement.*

Minor adjustment is made with the upper adjuster at the clutch lever.

Loosen the lock nut [1] and turn the adjuster [2].

Tighten the lock nut while holding the adjuster.

Recheck the clutch lever freeplay.

If the adjuster is threaded out near its limit and the correct freeplay cannot be obtained, turn the adjuster all the way in and back out one turn, then perform the adjustment at major adjuster as follows.

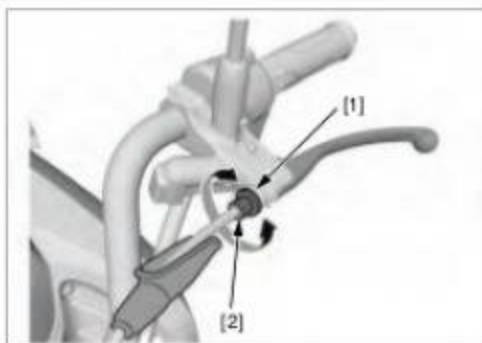

Major adjustment is made with the lower adjust nut [1] at the clutch lifter lever.

Loosen the lock nut [2] and turn the adjust nut to adjust the freeplay.

Tighten the lock nut while holding the adjust nut.

If proper freeplay cannot be obtained, or the clutch slips during test ride, disassemble and inspect the clutch (page 11-9).

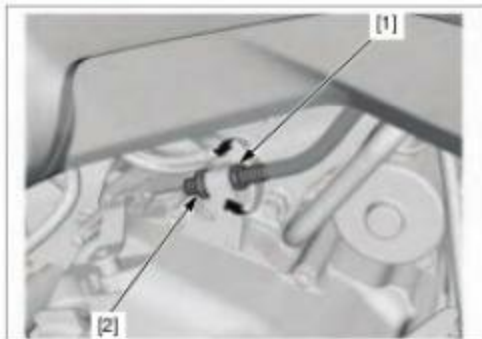

## SIDESTAND

Support the motorcycle using a safety stand or hoist.

Check the sidestand springs for damage or loss of tension.

Check the sidestand assembly for freedom of movement and lubricate the sidestand pivot if necessary.

## SUSPENSION

### FRONT SUSPENSION INSPECTION

Check the action of the forks by operating the front brake and compressing the front suspension several times.

Check the entire assembly for signs of leaks, damage or loose fasteners.

*Loose, worn or damaged suspension parts impair motorcycle stability and control.*

Replace damaged components which cannot be repaired.

Tighten all nuts and bolts.

### REAR SUSPENSION INSPECTION

Check the action of the rear shock absorbers by compressing them several times.

Check the entire shock absorber assembly for signs of leaks, damage or loose fasteners.

Tighten all nuts and bolts.

Place the motorcycle on a level surface.

Check for worn swingarm bushings by grabbing the rear ends of the swingarm and attempting to move the swingarm side to side.

Replace the swingarm bushings if any looseness is noted.

### NUTS, BOLTS, FASTENERS

Check that all chassis nuts and bolts are tightened to their correct torque values (page 1-10).

Check that all cotter pins, safety clips, hose clamps and cable stays are in place and properly secured.

### WHEELS/TIRES

Support the motorcycle securely and raise the front wheel off the ground.

Hold the fork leg and move the front wheel sideways with force to see if the wheel bearings are worn.

Check for worn wheel bearings by holding the swingarm and move the rear wheel sideways.

Replace the wheel bearings if any looseness is noted.

- Front wheel
- Rear wheel

Check the tire pressure with a tire pressure gauge when the tires are cold.

Check the tires for cuts, embedded nails, or other damage.

Check the front and rear wheels for trueness.

Measure the tread depth at the center of the tires.

Replace the tires when the tread depth reaches the following limits.

**MINIMUM TIRE TREAD DEPTH: To indicator**

### STEERING HEAD BEARINGS

Support the motorcycle securely and raise the front wheel off the ground.

Check that the handlebar moves freely from side to side. Make sure the control cables do not interfere with handlebar rotation.

Check for steering stem bearings by grabbing the fork legs and attempting to move the front fork side to side.

If the handlebar moves unevenly, binds, or has vertical movement, inspect the steering head bearings.

|  |      |                                 |      |
|--|------|---------------------------------|------|
| SERVICE INFORMATION .....                  | 4-2  | MIL CIRCUIT INSPECTION .....    | 4-22 |
| SYSTEM LOCATION .....                      | 4-3  | TP SENSOR RESET PROCEDURE ..... | 4-23 |
| SYSTEM DIAGRAM .....                       | 4-4  | ECM INITIALIZING PROCEDURE..... | 4-24 |
| PGM-FI SYMPTOM<br>TROUBLESHOOTING.....     | 4-5  | ALTITUDE SETTING .....          | 4-25 |
| PGM-FI TROUBLESHOOTING<br>INFORMATION..... | 4-6  | ECM .....                       | 4-26 |
| DTC INDEX .....                            | 4-9  | EOT SENSOR .....                | 4-27 |
| DTC TROUBLESHOOTING .....                  | 4-10 | BANK ANGLE SENSOR.....          | 4-27 |
|  |      | O2 SENSOR .....                 | 4-28 |

## PGM-FI SYSTEM

# SERVICE INFORMATION

### GENERAL

- A faulty PGM-FI system is often related to poorly connected or corroded connectors. Check those connections before proceeding.
- Use a digital tester for PGM-FI system inspection.
- The following color codes are used throughout this section.

Bu = Blue      G = Green      Lb = Light Blue      O = Orange      R = Red      Y = Yellow  
Bl = Black      Gr = Gray      Lg = Light Green      P = Pink      W = White      Br = Brown

### SPECIFICATIONS

| ITEM                     |               | SPECIFICATIONS                      |
|--------------------------|---------------|-------------------------------------|
| Engine idle speed        |               | 1,400 ± 100 min <sup>-1</sup> (rpm) |
| IAT sensor resistance    | (40°C/104°F)  | 21.2 – 16.4 kΩ                      |
| EOT sensor resistance    | (20°C/68°F)   | 2.5 – 2.8 kΩ                        |
|                          | (100°C/212°F) | 0.21 – 0.22 kΩ                      |
| Fuel injector resistance | (20°C/68°F)   | 11 – 13 Ω                           |

### TORQUE VALUES

#### PGM-FI SYSTEM

| ITEM                           | Q'TY | THREAD DIA. (mm) | TORQUE N-m (kgf-m, lbf-ft) | REMARKS  |
|--------------------------------|------|------------------|----------------------------|--|
| Bank angle sensor mounting nut | 2    | 6                | 10 (1.0, 7)                |  |
| Injector joint mounting bolt   | 2    | 5                | 12 (1.2, 9)                |  |
| EOT sensor                     | 1    | 10               | 14.5 (1.5, 11)             | Apply engine oil to the threads and seating surface. |
| O <sub>2</sub> sensor          | 1    | 12               | 24.5 (2.5, 18)             |  |

### TOOLS



## SYSTEM LOCATION

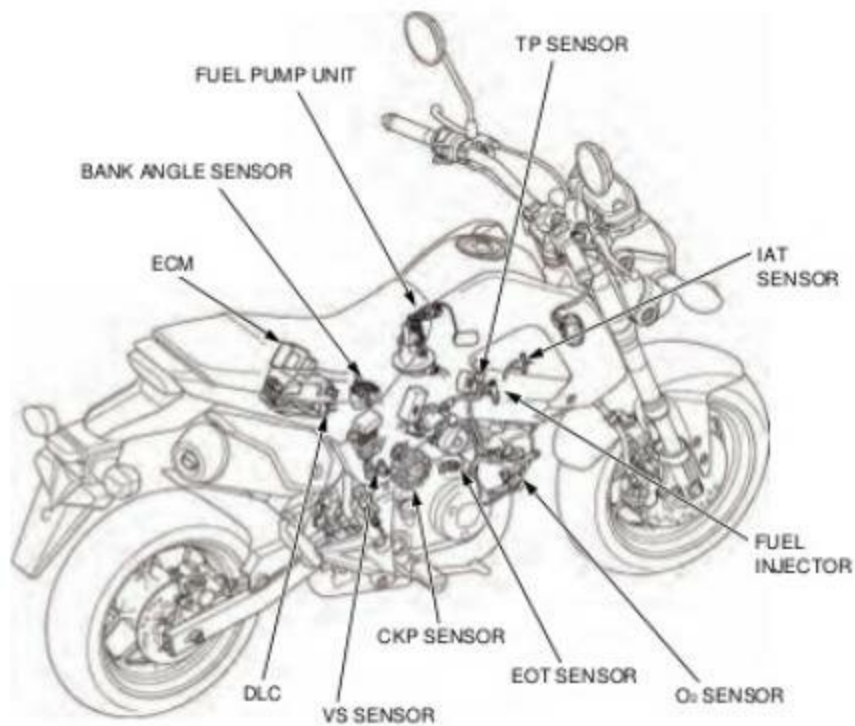

# PGM-FI SYSTEM SYSTEM DIAGRAM

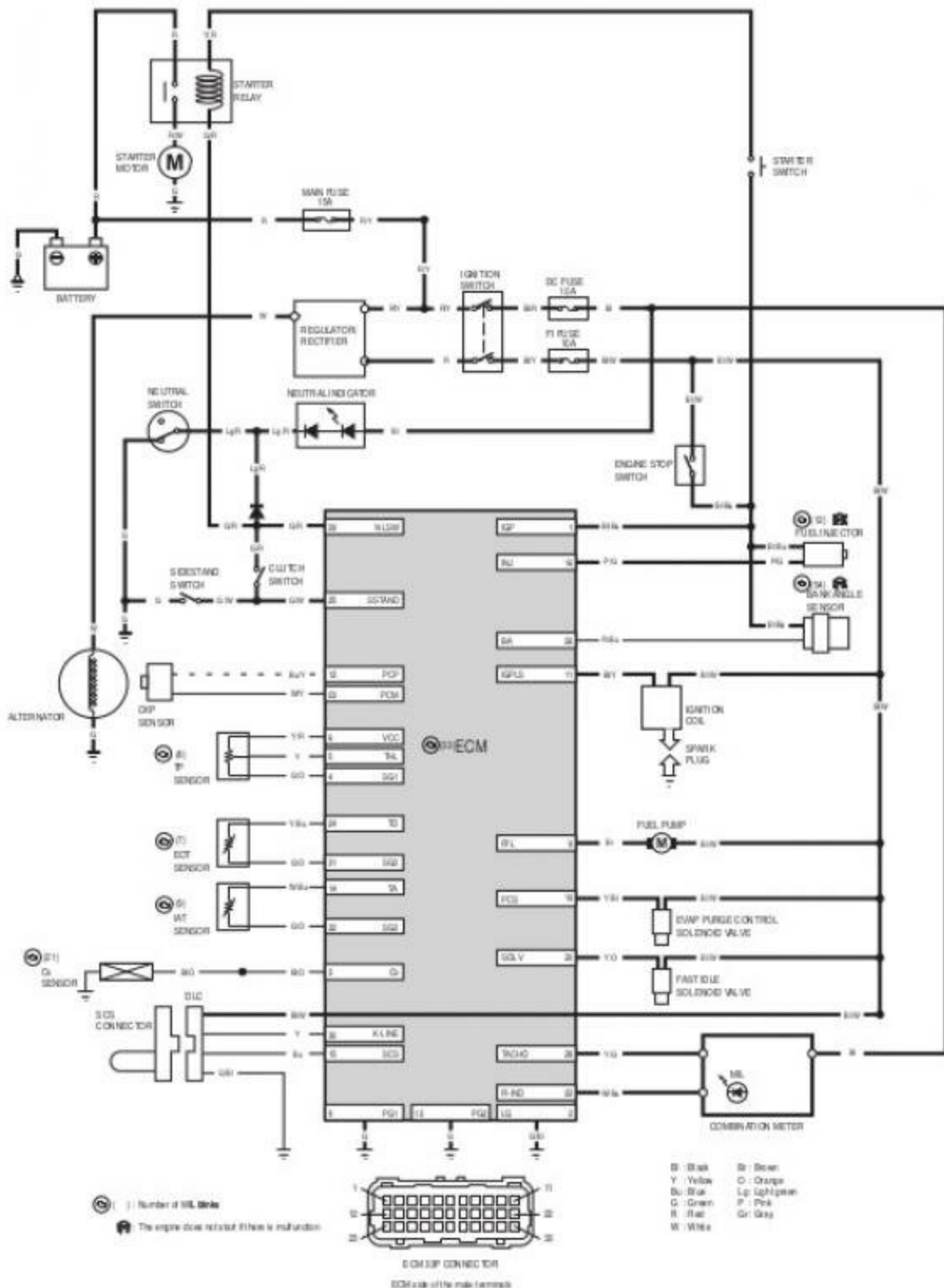

## PGM-FI SYMPTOM TROUBLESHOOTING

When the motorcycle has one of these symptoms, check the MIL blinking, refer to the DTC index (page 4-9) and begin the appropriate troubleshooting procedure. If there are no MIL blinking stored in the ECM memory, do the diagnostic procedure for the symptom, in sequence listed below, until you find cause.

| Symptom  | Diagnosis procedure  | Also check for  |
|--|--|---|
| Engine cranks but won't start<br>(No DTC and MIL blinking)                                   | <ol style="list-style-type: none"> <li>1. ECM initializing (page 4-24).</li> <li>2. Check the spark plug condition (page 3-5).</li> <li>3. Inspect the ignition system (page 5-5).</li> <li>4. Check the cylinder compression (page 9-6).</li> <li>5. Check the idle air port/screw (page 7-8).</li> <li>6. Check the fuel supply system (page 7-3).</li> </ol>      | <ul style="list-style-type: none"> <li>• No fuel to fuel injector               <ul style="list-style-type: none"> <li>– Clogged fuel filter</li> <li>– Clogged fuel filler cap breather hole</li> <li>– Pinched or clogged fuel feed hose</li> <li>– Faulty fuel pump</li> <li>– Faulty fuel pump circuits</li> </ul> </li> <li>• Intake air leak</li> <li>• Contaminated/deteriorated fuel</li> <li>• Faulty fuel injector</li> </ul> |
| Engine cranks but won't start<br>(No fuel pump operation sound when turning the ignition ON) | <ol style="list-style-type: none"> <li>1. ECM power/ground line malfunction (page 4-26).</li> <li>2. Check the fuel supply system (page 7-3).</li> </ol>   | <ul style="list-style-type: none"> <li>• Faulty main fuse 15 A</li> <li>• Faulty sub fuse 10 A (FI,DC)</li> </ul>   |
| Engine stalls, hard to start, rough idling   | <ol style="list-style-type: none"> <li>1. ECM initializing (page 4-24).</li> <li>2. Check the engine idle speed (page 3-8).</li> <li>3. Check the idle air port/screw (page 7-8).</li> <li>4. Inspect the fuel supply system (page 7-3).</li> <li>5. Inspect the battery charging system (page 18-5).</li> <li>6. Inspect the ignition system (page 5-5).</li> </ol> | <ul style="list-style-type: none"> <li>• Restricted fuel feed hose</li> <li>• Clogged fuel filler cap breather hole</li> <li>• Contaminated/deteriorated fuel</li> <li>• Intake air leak</li> </ul>   |
| Backfiring or misfiring during acceleration  | Inspect the ignition system (page 5-5).  |   |
| Poor performance (driveability) and poor fuel economy  | <ol style="list-style-type: none"> <li>1. Check the fuel supply system (page 7-3).</li> <li>2. Check the air cleaner element (page 3-4).</li> <li>3. Inspect the ignition system (page 5-5).</li> </ol>  | <ul style="list-style-type: none"> <li>• Pinched or clogged fuel feed hose</li> <li>• Faulty pressure regulator (fuel pump)</li> <li>• Faulty fuel injector</li> </ul>  |
| Engine idle speed is below specifications  | <ol style="list-style-type: none"> <li>1. Check the engine idle speed (page 3-8).</li> <li>2. Check the idle air port/screw (page 7-8).</li> <li>3. Inspect the ignition system (page 5-5).</li> <li>4. Check the fuel supply system (page 7-3).</li> </ol>  |   |
| Engine idle speed is above specifications  | <ol style="list-style-type: none"> <li>1. Check the engine idle speed (page 3-8).</li> <li>2. Check the idle air port/screw (page 7-8).</li> <li>3. Inspect the ignition system (page 5-5).</li> <li>4. Check the throttle operation and freeplay (page 3-4).</li> <li>5. Check the air cleaner element (page 3-4).</li> </ol>                                       | <ul style="list-style-type: none"> <li>• Intake air leak</li> <li>• Engine top-end problem</li> </ul>   |
| MIL stays ON or MIL never comes ON at all (Engine operates normally)                         | Inspect the MIL circuit (page 4-22).   |   |
| MIL stays ON (Engine operates normally and No DTC set)                                       | <ol style="list-style-type: none"> <li>1. Inspect the MIL circuit (page 4-22).</li> <li>2. Inspect the DLC circuit.</li> </ol>   |   |

# PGM-FI TROUBLESHOOTING INFORMATION

## GENERAL TROUBLESHOOTING

### INTERMITTENT FAILURE

The term "intermittent failure" means a system may have had a failure, but it checks OK now. If the MIL does not come on, check for poor contact or loose pins at all connectors related to the circuit. If the MIL was on, but then went out, the original problem may be intermittent.

### OPENS AND SHORTS

"Opens" and "Shorts" are common electrical terms. An open is a break in a wire or at a connection. A short is an accidental connection of a wire to ground or to another wire. In simple electronics, this usually means something will not work at all. With ECMs this can sometimes mean something works, but not the way it's supposed to.

#### If the Engine has problem, and MIL comes on

Refer to DTC READOUT (page 4-7).

#### If the Engine has problem, but MIL does not stay on or blink

Refer to the SYMPTOM TROUBLESHOOTING (page 4-5).

## SYSTEM DESCRIPTION

### SELF-DIAGNOSIS SYSTEM

The PGM-FI system is equipped with the self-diagnostic system. When any abnormality occurs in the system, the ECM turns on the MIL (Malfunction Indicator Lamp) and stores a DTC in its erasable memory.

### CURRENT DTC/STORED DTC

The DTC is indicated in two ways according to the failure status.

- In case the ECM detects the problem at present, the MIL will start blinking as its DTC. It is possible to read out the MIL blink pattern as the current DTC.
- In case the ECM does not detect any problem at present but has a problem stored in its memory, the MIL will not blink. If it is necessary to retrieve the past problem, read out the stored DTC by following the DTC readout procedure (page 4-7).

### MIL BLINK PATTERN

- DTC can be read by the MIL blink pattern.
- In case the ECM does not detect any problem at present, when the ignition switch is turned "ON", the MIL will stay on for a few seconds, then go off.
- In case the ECM detects the problem at present, when the ignition switch is turned "ON", the MIL will stay on for a few seconds and go off, then the MIL blinks as its DTC.
- The MIL has two types of blinks, a long blink and short blink. The long blinking lasts for 1.3 seconds, the short blinking lasts for 0.3 seconds. One long blink is the equivalent to ten short blinks. For example, when two long blinks are followed by five short blinks, the MIL is 25 (two long blinks = 20 blinks, plus five short blinks).
- The MIL will start blinking when the ignition switch is "ON" or engine revs are below 1800 min<sup>-1</sup> (rpm). In any other conditions, the MIL will illuminate and stay on.

### MIL CIRCUIT CHECK

If the MIL does not come on or stays on when the ignition switch is turned "ON", inspect the MIL circuit (page 4-22).

### FAIL-SAFE FUNCTION

The PGM-FI system is provided with a fail-safe function to secure a minimum running capability even when there is trouble in the system. When any abnormality is detected by the self-diagnosis function, running capability is maintained by pre-programmed value in the simulated program map. When any abnormality is detected in the fuel injector and/or crankshaft position (CKP) sensor, the fail-safe function stops the engine to protect it from damage.

## MCS INFORMATION

- The MCS can readout the DTC, freeze data, current data and other ECM condition.

### How to connect the MCS

Turn the ignition switch "OFF".

Remove the seat (page 2-3).

Remove the connector cover from the DLC [1] and connect the MCS to the DLC.

### NOTE:

- Freeze data indicates the engine conditions when the first malfunction was detected.

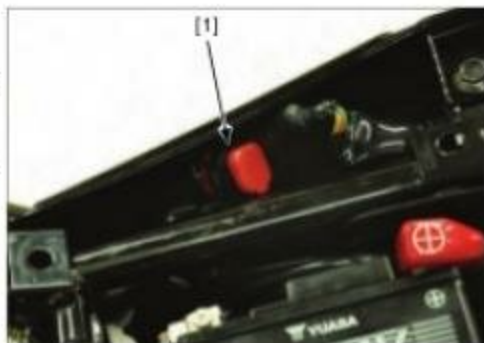

## DTC READOUT

### CURRENT DTC

Place the motorcycle on a level surface and check the MIL.

- When the ignition switch is turned "ON", the MIL will stay on for a few seconds, then go off.

If the MIL stays on or blinks, note how many times the MIL blinks and determine the cause of the problem.

If the MIL does not blink, the system is normal at present. If you wish to read the stored DTC, perform the following:

### TO READ THE STORED DTC

Turn the ignition switch "OFF".

Remove the seat (page 2-3).

Remove the connector cover from the DLC [1] and short the DLC terminals using the special tool.

### TOOL:

[2] SCS connector 070PZ-ZY30100

CONNECTION: Blue – Green/black

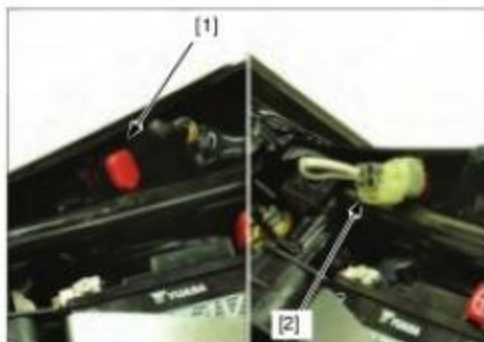

If the ECM has no stored DTC, the MIL will illuminate, when you turn the ignition switch "ON".

If the ECM has stored DTC, the MIL will illuminate 0.3 seconds and go off, then start blinking as its DTC when you turn the ignition switch "ON".

Note how many times the MIL blinks, and determine the cause of the problem.

## PGM-FI SYSTEM

### ERASING DTC

Connect the MCS to the DLC.

Erase the DTC with the MCS while the engine is stopped.

To erase the DTC without MCS, refer to the following procedure.

#### How to erase the DTC with SCS service connector

1. Turn the ignition switch "OFF".
2. Remove the front body cover (page 2-6).
3. Remove the connector cover from the DLC [1] and short the DLC terminals using the special tool.

#### TOOL:

[2] SCS connector 070PZ-ZY30100

CONNECTION: Blue - Green/black

4. Turn the ignition switch "ON".
5. Disconnect the SCS connector [1] from the DLC [2].  
Connect the DLC short connector to the DLC again while the MIL stays ON about 5 seconds (reset receiving pattern).
6. The stored DTC is erased if the MIL goes off and starts blinking (successful pattern).

- The DLC must be jumped while the MIL lights. If not, the MIL will go off and stay on (unsuccessful pattern). In that case, turn the ignition switch to "OFF" and try again from step 3.
- Note that the self-diagnostic memory cannot be erased if the ignition switch is turned "OFF" before the MIL starts blinking.

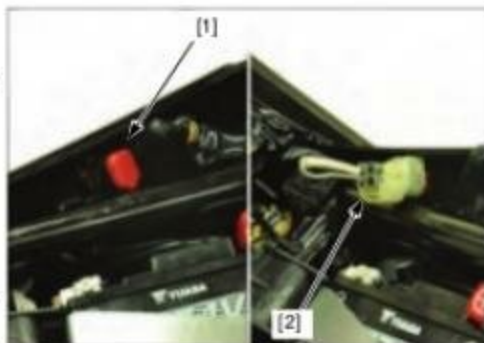

### CIRCUIT INSPECTION

#### INSPECTION AT ECM AND SENSOR UNIT CONNECTOR

- Always clean around and keep any foreign material away from the connector before disconnecting it.
- A faulty PGM-FI system is often related to poorly connected or corroded connections. Check those connections before proceeding.
- When testing at connector (wire harness side) terminal, always use the test probe [1]. Insert the test probe into the connector terminal, then connect the digital multimeter probe to the test probe.

#### TOOL:

[1] Test probe 07ZAJ-RDJA110

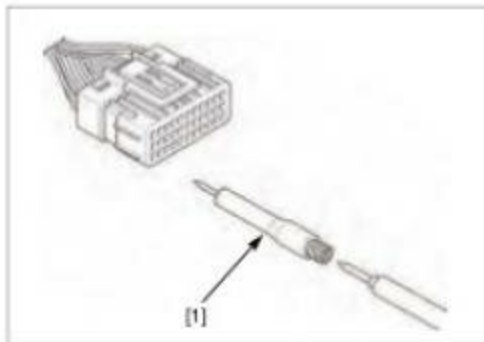

## DTC INDEX

## NOTE:

- If not using the MCS, perform all inspections according to the relevant main code.

| DTC  | Function Failure  | Symptom/Fail-safe function  | Refer to |
|------|---|---|----------|
| 7-1  | EOT sensor circuit low voltage (less than 0.07 V)<br>• EOT sensor or its circuit malfunction  | • Hard start at a low temperature<br>• Pre-program value: 100°C/212°F   | 4-10     |
| 7-2  | EOT sensor circuit high voltage (more than 4.93 V)<br>• Loose or poor contact of the EOT sensor connector<br>• EOT sensor or its circuit malfunction                      | • Hard start at a low temperature<br>• Pre-program value: 100°C/212°F   | 4-11     |
| 8-1  | TP sensor circuit low voltage (less than 0.3 V)<br>• Loose or poor contact of the TP sensor connector<br>• TP sensor or its circuit malfunction                           | • Poor engine acceleration<br>• Pre-program value: 0°   | 4-12     |
| 8-2  | TP sensor circuit high voltage (more than 4.93 V)<br>• TP sensor or its circuit malfunction   | • Poor engine acceleration<br>• Pre-program value: 0°   | 4-14     |
| 9-1  | IAT sensor circuit low voltage (more than 0.07 V)<br>• IAT sensor or its circuit malfunction  | • Engine operates normally<br>• Pre-program value: 35°C/95°F  | 4-15     |
| 9-2  | IAT sensor circuit high voltage (less than 4.93 V)<br>• Loose or poor contact of the IAT sensor connector<br>• IAT sensor or its circuit malfunction                      | • Engine operates normally<br>• Pre-program value: 35°C/95°F  | 4-16     |
| 12-1 | Fuel injector malfunction<br>• Loose or poor contact of the fuel injector connector<br>• Fuel injector or its circuit malfunction   | • Engine does not start<br>• Fuel injector, fuel pump and ignition coil shut down   | 4-17     |
| 21-1 | O <sub>2</sub> sensor malfunction<br>• Loose or poor contact of the O <sub>2</sub> sensor connector<br>• O <sub>2</sub> sensor or its circuit malfunction                 | • Engine operates normally  | 4-18     |
| 33-2 | EEPROM malfunction  | • Engine stalls, hard to start, rough idling  | 4-19     |
| 54-1 | Bank angle sensor circuit low voltage (less than 0.02 V)<br>• Loose or poor contact of the bank angle sensor connector<br>• Bank angle sensor or its circuit malfunction  | • Engine operates normally<br>• Bank angle sensor does not operate.<br>(The engine keeps running when the vehicle falls.) | 4-20     |
| 54-2 | Bank angle sensor circuit high voltage (more than 4.98 V)<br>• Loose or poor contact of the bank angle sensor connector<br>• Bank angle sensor or its circuit malfunction | • Engine operates normally<br>• Bank angle sensor does not operate.<br>(The engine keeps running when the vehicle falls.) | 4-21     |

## DTC TROUBLESHOOTING

## DTC 7 (EOT SENSOR)

- Before starting the inspection, check for loose or poor contact on the EOT sensor 2P connector and ECM 33P (Black) connector and recheck the MIL blinking.

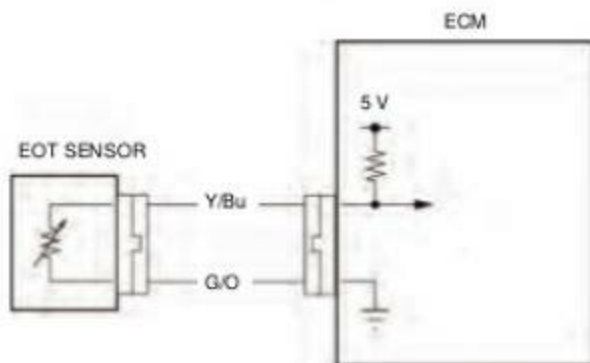

## Probable cause

- Open or short circuit in Yellow/blue wire between the EOT sensor and ECM
- Open circuit in Green/Orange wire between the EOT sensor and ECM
- Faulty EOT sensor
- Faulty ECM

## DTC 7-1 (EOT SENSOR LOW VOLTAGE)

## 1. EOT Sensor System Inspection

Turn the ignition switch "ON" and engine stop switch "O".

Check the EOT sensor with the MCS.

**Is about 0 V indicated?**

**YES** – GO TO STEP 2.

**NO** – Intermittent failure

## 2. EOT Sensor Inspection

Turn the ignition switch "OFF".

Disconnect the EOT sensor 2P connector.

Turn the ignition switch "ON" and engine stop switch "O".

Check the EOT sensor with the MCS.

**Is about 0 V indicated?**

**YES** – GO TO STEP 4.

**NO** – GO TO STEP 3.

## 3. EOT Sensor Resistance Inspection

Turn the ignition switch "OFF".

Measure the resistance at the sensor side of the EOT sensor 2p connector terminals.

**CONNECTION: Yellow/blue – Green/orange**

**STANDARD: 2.5 – 2.8 k $\Omega$  (20°C/68°F)**

**Is the resistance within 2.5 – 2.8 k $\Omega$ ?**

**YES** – Replace the ECM with a known good one, and recheck.

**NO** – Faulty EOT sensor

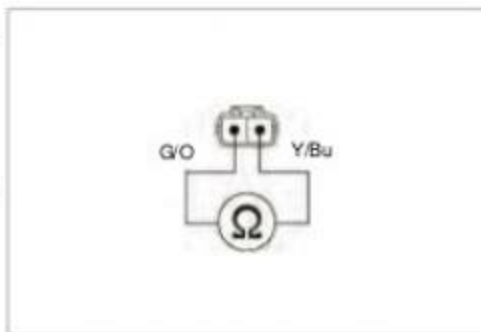

#### 4. EOT Sensor Output Line Short Circuit Inspection

Turn the ignition switch "OFF".  
Check the continuity between the EOT sensor 2p connector of the wire harness side and ground.

**CONNECTION: Yellow/blue – Ground**

*Is there continuity?*

**YES** – Short circuit Green/orange wire

**NO** – Replace the ECM with a known good one, and recheck.

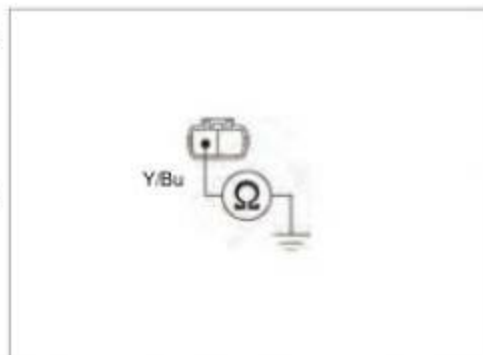

#### DTC 7-2 (EOT SENSOR HIGH VOLTAGE)

##### 1. EOT sensor System Inspection

Turn the ignition switch ON and engine stop switch "O".

Check the EOT sensor with the MCS.

*Is about 5 V indicated?*

**YES** – GO TO STEP 2.

**NO** – Intermittent failure

##### 2. EOT sensor Inspection

Turn the ignition switch "OFF".

Disconnect the EOT sensor 2P connector [1].

Connect the EOT sensor 2P connector terminals at the wire side with a jumper wire.

**CONNECTION: Yellow/blue – Green/orange**

Turn the ignition switch "ON" and engine stop switch "O".

Check the EOT sensor with the MCS.

*Is about 0 V indicated?*

**YES** – Faulty EOT sensor

**NO** – GO TO STEP 3.

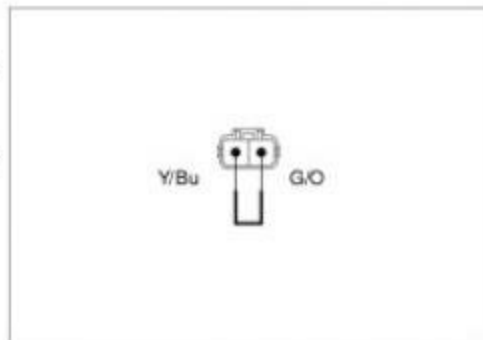

##### 3. EOT sensor Output Line Circuit Inspection

Turn the ignition switch "OFF".

Remove the jumper wire.

Disconnect the ECM 33P connectors.

Check for continuity between the EOT sensor 2P connector and ECM 33P connectors at the wire harness side.

**CONNECTION: 24 – Yellow/blue  
31 – Green/orange**

**TOOL:**

**Pin Probe Male (2 pack) 07ZAJ-RDJA110**

*Is there continuity?*

**YES** – Replace the ECM with a known good one, and recheck.

**NO** – • Open circuit in Yellow/blue wire  
• Open circuit in Green/orange wire

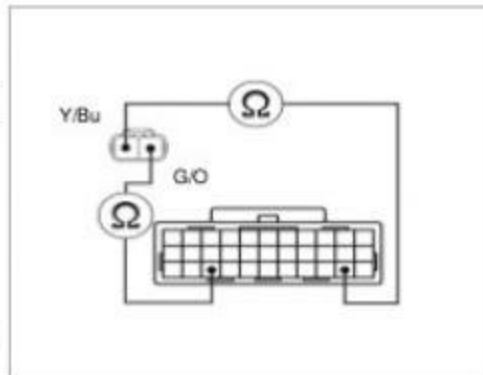

**DTC 8 BLINKS (TP SENSOR)**

- Before starting the inspection, check for loose or poor contact on the TP sensor 3P connector and ECM 33P (Black) connector and recheck the MIL blinking.

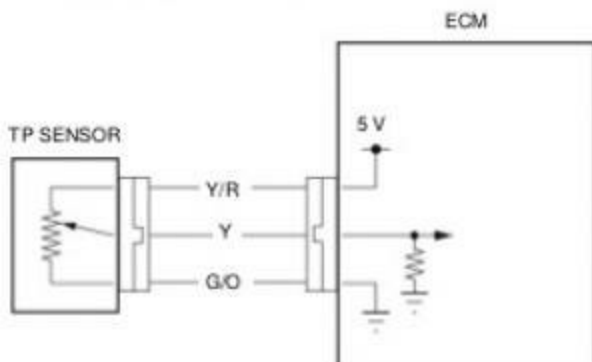

**Probable cause**

- Open circuit in Yellow/red wire between the TP sensor and ECM
- Open or short circuit in Yellow wire between the TP sensor and ECM
- Open circuit in Green/orange wire between the TP sensor and ECM
- Faulty TP sensor
- Faulty ECM

**DTC 8-1 (TP SENSOR LOW VOLTAGE)**

**1. TP Sensor System Inspection**

Turn the ignition switch "ON" and engine stop switch "O".  
Check the TP sensor with the MCS when the throttle is fully closed.

**Is about 0 V indicated?**

**YES** – GO TO STEP 3.

**NO** – GO TO STEP 2.

**2. TP Sensor Inspection**

Check that the TP sensor voltage increases continuously when moving the throttle from fully closed to fully opened using the data list menu of the MCS.

**Does the voltage increase continuously?**

**YES** – Intermittent failure

**NO** – Faulty TP sensor

**3. TP Sensor Resistance Inspection**

Turn the ignition switch "OFF".  
Disconnect the TP sensor 3P connector (page 7-8).  
Measure the resistance at the sensor side of the TP sensor 3P connector terminals.

**CONNECTION: Yellow – Green/orange**

*Is the resistance within 0.5 – 1.5 k $\Omega$  (20°C/68°F)?*

- YES** – GO TO STEP 4.  
**NO** – Faulty TP sensor

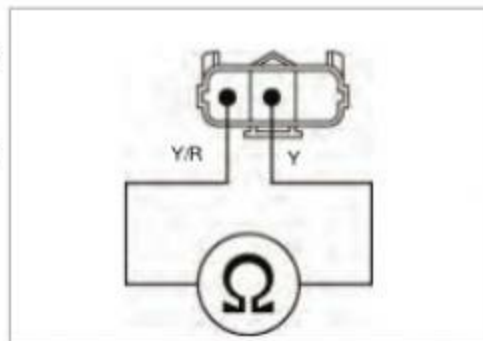
**4. TP Sensor Output Line Open Circuit Inspection**

Turn the ignition switch OFF.  
Disconnect the ECM 33P (Gray) connector.  
Check for continuity between the TP sensor 3P connector and ECM 33P (Gray) connector at the wire harness side.

**CONNECTION: 5 – Yellow**

*Is there continuity?*

- YES** – GO TO STEP 5.  
**NO** – Open circuit in yellow wire

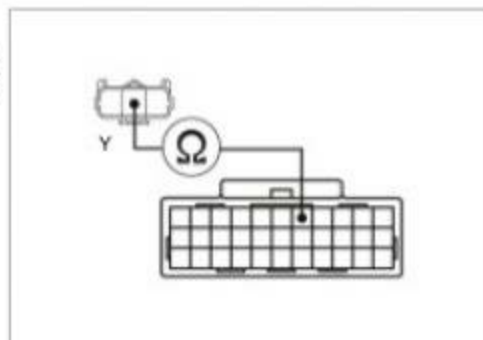
**5. TP Sensor Output Line Short Circuit Inspection**

Check for continuity between the TP sensor 3P connector at the wire side and ground.

**CONNECTION: Yellow – Ground**

*Is there continuity?*

- YES** – Short circuit in yellow wire  
**NO** – GO TO STEP 6.

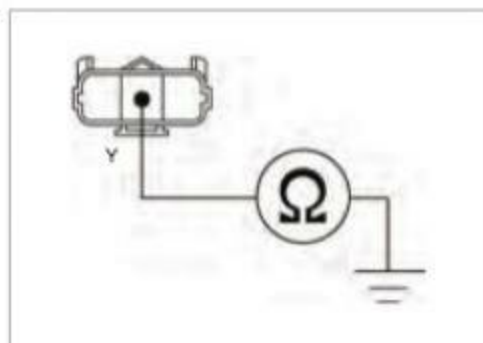
**6. TP Sensor Power Input Voltage Inspection**

Turn the ignition switch "OFF".  
Disconnect the TP sensor 3P connector (page 7-8).  
Turn the ignition switch "ON" and engine stop switch "O".  
Measure the voltage at the TP sensor 3P connector of the wire harness side.

**CONNECTION: Yellow/red (+) – Green/orange (-)**  
**STANDARD: 4.75 – 5.25 V**

*Is the voltage within 4.75 – 5.25 V?*

- YES** – Faulty TP sensor  
**NO** – GO TO STEP 7.

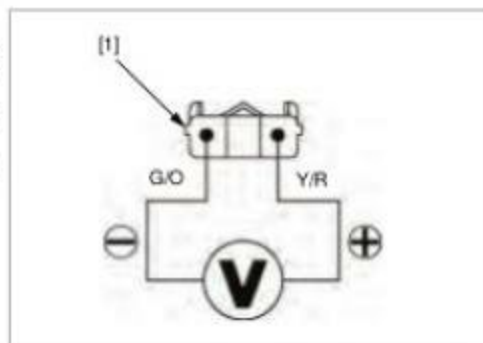

**7. TP Sensor Input Line Circuit Inspection**

Turn the ignition switch "OFF".  
Disconnect the ECM 33P (Black) connector (page 4-26).

Check for continuity between the TP sensor 3P connector and ECM 33P (Black) connector of the wire harness side.

**TOOL:**

**Test probe** 07ZAJ-RDJA110

**CONNECTION:** 6 - Yellow/red  
4 - Green/orange

**Are there continuity?**

**YES** - Replace the ECM with a known good one, and recheck.

**NO** - • Open circuit in Yellow/red wire  
• Open circuit in Green/orange wire

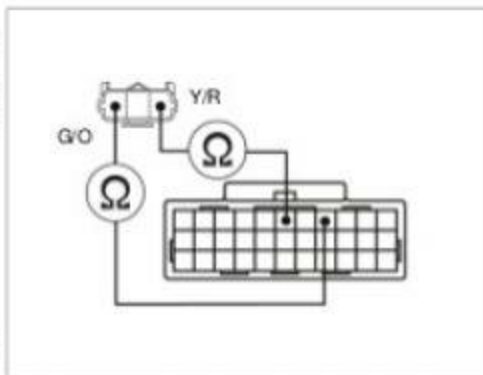

**DTC 8-2 (TP SENSOR HIGH VOLTAGE)**

**1. TP Sensor System Inspection**

Turn the ignition switch "ON" and engine stop switch "0".  
Check the TP sensor with the MCS when the throttle is fully closed.

**Is about 0 V indicated?**

**YES** - GO TO STEP 3.

**NO** - GO TO STEP 2.

**2. TP sensor Inspection**

Check that the TP sensor voltage increases continuously when moving the throttle from fully closed to fully opened using the data list menu of the MCS.

**Does the voltage increase continuously?**

**YES** - Intermittent failure

**NO** - Faulty TP sensor

**3. TP Sensor Resistance Inspection**

Turn the ignition switch "OFF".  
Disconnect the TP sensor 3P connector (page 7-8).  
Measure the resistance at the sensor side of the TP sensor 3P connector terminals.

**CONNECTION:** Yellow/red - Green/orange

**Is the resistance within 0.5 - 1.5 kΩ (20°C/68°F)?**

**YES** - GO TO STEP 4.

**NO** - Faulty TP sensor

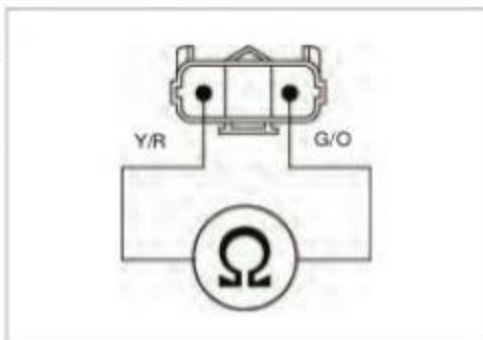

**4. TP Sensor Input Voltage Inspection**

Turn the ignition switch ON and engine stop switch "O".

Measure the voltage at the wire side of the TP sensor 3P connector terminals.

**Connection: Yellow/red – Green/orange**

**Is the voltage within 4.75 – 5.25 V?**

- YES** – Replace the ECM with a known good one, and recheck.
- NO** – Open circuit in Yellow/red or Green/orange wire

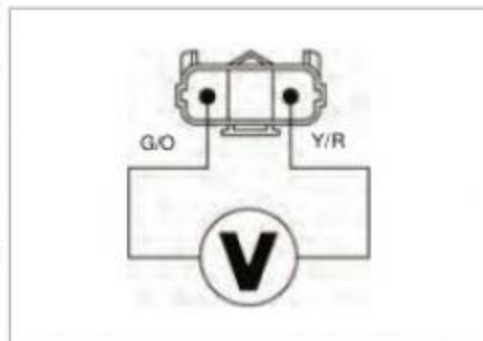
**DTC 9 (IAT SENSOR)**

- Before starting the inspection, check for loose or poor contact on the IAT sensor 2P (Black) connector and ECM 33P connectors, then recheck the DTC.

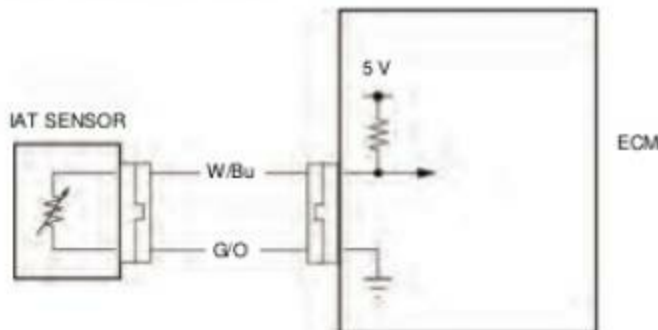
**Probable cause**

- Open or short circuit in Gray/blue wire between the IAT sensor and ECM
- Open circuit in Light green/red wire between the IAT sensor and ECM
- Faulty IAT sensor
- Faulty ECM

**DTC 9-1 (IAT SENSOR LOW VOLTAGE)****1. IAT Sensor System Inspection**

Turn the ignition switch ON and engine stop switch "O".

Check the IAT sensor with the MCS.

**Is about 0 V indicated?**

- YES** – GO TO STEP 2.
- NO** – Intermittent failure

**2. IAT Sensor Inspection**

Turn the ignition switch OFF.  
Disconnect the IAT sensor 2P (Black) connector.

Turn the ignition switch ON and engine stop switch "O".

Check the IAT sensor with the MCS.

**Is about 0 V indicated?**

- YES** – GO TO STEP 3.
- NO** – Faulty IAT sensor

3. IAT Sensor Output Line Short Circuit Inspection

Turn the ignition switch OFF.

Check for continuity between the IAT sensor 2P connector at the wire harness side and ground.

**Connection: White/blue – Ground**

*Is there continuity?*

**YES** – Short circuit in White/blue wire

**NO** – Replace the ECM with a known good one, and recheck.

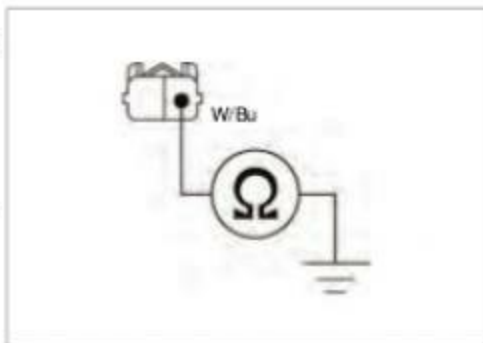

DTC 9-2 (IAT SENSOR HIGH VOLTAGE)

1. IAT Sensor System Inspection

Turn the ignition switch ON and engine stop switch "O".

Check the IAT sensor with the MCS.

*Is about 5 V indicated?*

**YES** – GO TO STEP 2.

**NO** – Intermittent failure

2. IAT Sensor Inspection

Turn the ignition switch OFF.

Disconnect the IAT sensor 2P connector.

Connect the IAT sensor 2P connector terminals at the wire harness side with a jumper wire.

**Connection: White/blue – Green/orange**

Turn the ignition switch ON and engine stop switch "O".

Check the IAT sensor with the MCS.

*Is about 0 V indicated?*

**YES** – Faulty IAT sensor.

**NO** – GO TO STEP 3.

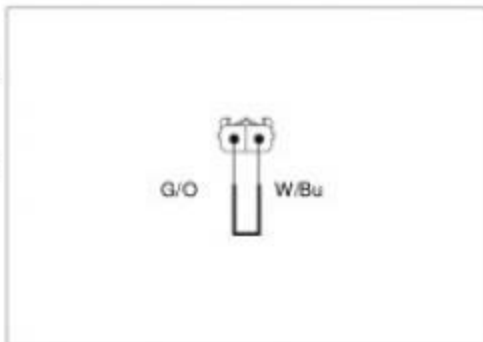

3. IAT Sensor Line Inspection

Turn the ignition switch OFF.

Remove the jumper wire.

Disconnect the ECM 33P connectors.

Check for continuity between the IAT sensor 2P connector and ECM 33P and connectors at the wire harness side.

**Connection: 14 – White/blue  
32 – Green/orange**

**TOOL:**

**Pin Probe Male (2 pack) 07ZAJ-RDJA110**

*Is there continuity?*

**YES** – Replace the ECM with a known good one, and recheck.

**NO** – • Open circuit in White/blue wire  
• Open circuit in Green/orange wire

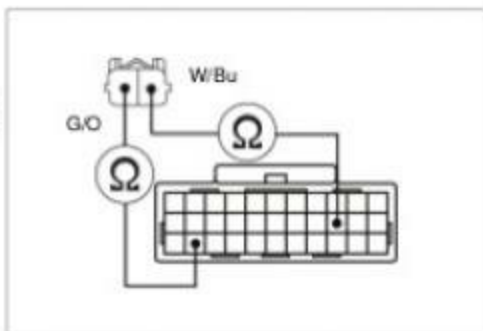

**DTC 12 (FUEL INJECTOR)**

- Before starting the inspection, check for loose or poor contact on the fuel injector 2P connector and ECM 33P (Black) connector and recheck the MIL blinking.

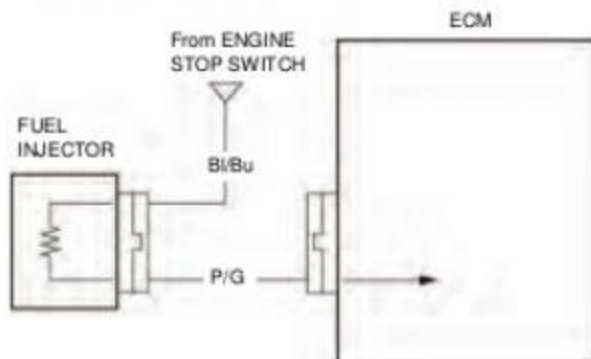
**Probable cause**

- Open circuit in Black/blue wire between the engine stop switch and fuel injector
- Open or short circuit in Pink/green wire between the Fuel injector and ECM
- Faulty fuel injector
- Faulty ECM

**DTC 12-1 (FUEL INJECTOR)****1. Fuel Injector System Inspection**

Erase the DTCs (page 4-8).

Start the engine and check the fuel injector with the MCS.

**Is DTC 12-1 indicated?**

**YES** – GO TO STEP 2.

**NO** – Intermittent failure

**2. Fuel injector Input Voltage Inspection**

Turn the ignition switch "OFF".

Disconnect the fuel injector 2P connector (page 7-9).

Turn the ignition switch ON and engine stop switch "O".

Measure the voltage between the fuel injector 2P connector of the wire harness side and ground.

**CONNECTION: Black/blue (+) – Ground (-)**

**STANDARD: Battery voltage**

**Does the standard voltage exist?**

**YES** – GO TO STEP 3.

**NO** – Open or short circuit in Black/blue wire

**3. Fuel injector Signal Line Short Circuit Inspection**

Turn the ignition switch "OFF".

Check the continuity between the fuel injector 2P connector of the wire harness side and ground.

**Is there continuity?**

**YES** – Short circuit in the Pink/green wire.

**NO** – GO TO STEP 4.

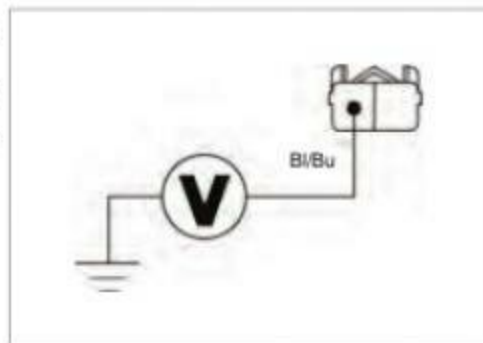

**4. Fuel injector Resistance Inspection**

Measure the resistance between the terminals of the fuel injector side 2P connector.

**STANDARD:** 11 - 13  $\Omega$  (20°C/68°F)

*Is the resistance within 11 - 13  $\Omega$  (20°C/68°F)?*

**YES** – GO TO STEP 5.

**NO** – Faulty fuel injector

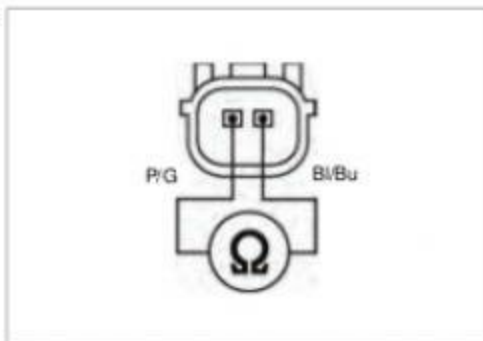

**5. Fuel injector Signal Line Open Circuit Inspection**

Turn the ignition switch "OFF".  
Disconnect the ECM 33P (Black) connector (page 4-26).

Check the continuity between the ECM 33P connector and injector 2P connector of the wire harness side.

**TOOL:**

**Pin Probe Male (2 pack) 07ZAJ-RDJA110**

**CONNECTION:** 16 – Pink/Green

**STANDARD:** Continuity

*Are the above inspections normal?*

**YES** – Replace the ECM with a known good one, and recheck.

**NO** – Open circuit in Pink/green wire

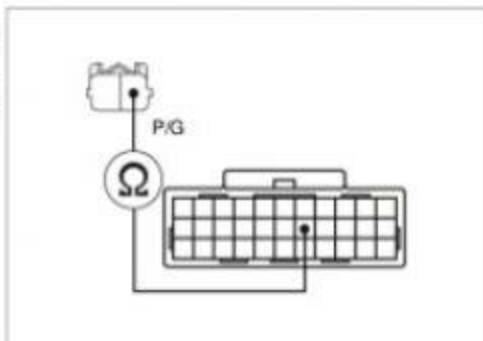

**DTC 21 (O<sub>2</sub> SENSOR)**

- Before starting the inspection, check for loose or poor contact on the O<sub>2</sub> sensor cap, O<sub>2</sub> sensor 1P connector and ECM 33P (Black) connector and recheck the MIL blinking.

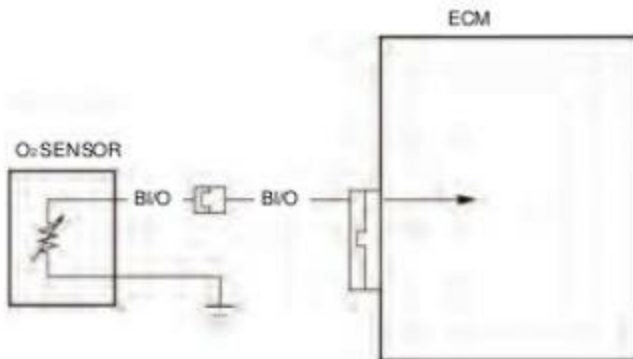

Probable cause

- Open or short circuit in Black/orange wire between the O<sub>2</sub> sensor and ECM
- Faulty O<sub>2</sub> sensor
- Faulty ECM

**DTC 21-1 (O<sub>2</sub> SENSOR)****1. O<sub>2</sub> Sensor Open Circuit Inspection**

Turn the ignition switch "OFF".

Disconnect the ECM 33P (Black) connector (page 4-26) and O<sub>2</sub> sensor cap.

Check the continuity between the terminal of the O<sub>2</sub> sensor cap and ECM 33P connector of the wire harness side.

**CONNECTION: O<sub>2</sub> sensor cap terminal – 3**

*Is there continuity?*

**YES** – GO TO STEP 2.

**NO** – Open circuit in Black/orange wire

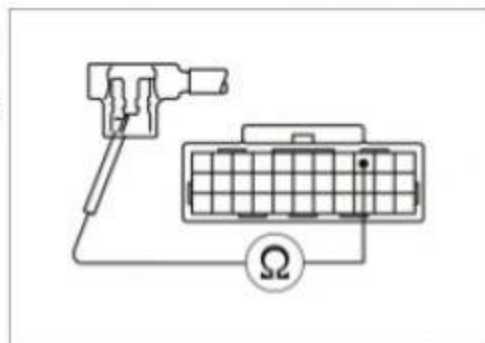
**2. O<sub>2</sub> Sensor Short Circuit Inspection**

Turn the ignition switch "OFF".

Disconnect the ECM 33P connector (page 4-26) and O<sub>2</sub> sensor cap.

Check the continuity between the terminal of the O<sub>2</sub> sensor cap and ground.

**CONNECTION: O<sub>2</sub> sensor cap terminal – Ground**

*Is there continuity?*

**YES** – Short circuit in Black/orange wire

**NO** – GO TO STEP 3.

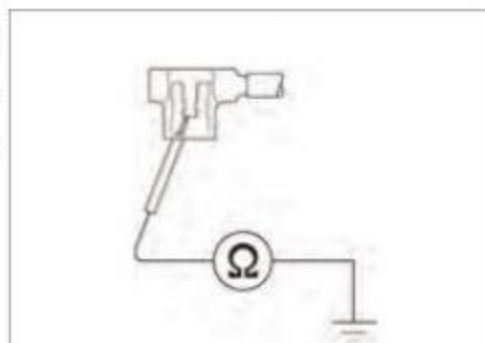
**3. O<sub>2</sub> Sensor Inspection**

Replace the O<sub>2</sub> sensor with a known good one (page 4-28).

Perform the ECM initializing procedure (page 4-24).  
Erase the self diagnosis memory data from the ECM (page 4-8).

Start the engine and warm it up.

Test-ride the motorcycle and recheck the O<sub>2</sub> sensor with the MCS.

*Does the DTC21-1 indicated?*

**YES** – Replace the ECM with a known good one, and recheck.

**NO** – Faulty original O<sub>2</sub> sensor

**DTC 33 BLINKS (EEPROM)****DTC 33-2 (EEPROM)****1. Recheck MIL**

Erase the DTC (page 4-8).

Perform the ECM initializing procedure (page 4-24).

*Is DTC 33-2 indicated?*

**YES** – Replace the ECM with a known good one, and recheck.

**NO** – Intermittent failure

## DTC 54 BLINKS (BANK ANGLE SENSOR)

**NOTE:**

Before starting the inspection, check for loose or poor contact on the bank angle sensor 2P connector and recheck the MIL blinking.

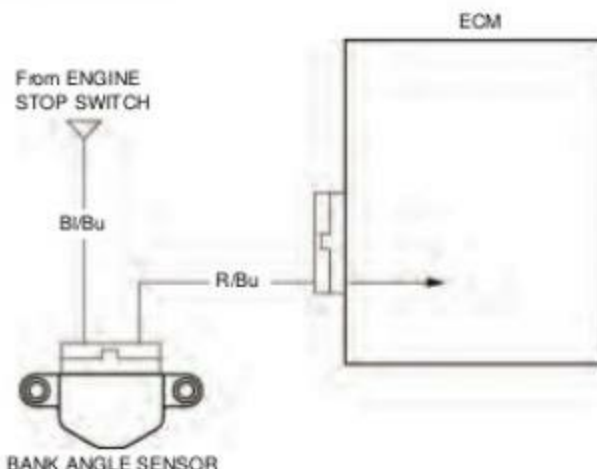

**Probable cause**

- Open circuit in Black/blue wire between the engine stop switch and bank angle sensor
- Open or short circuit in Red/blue wire between the bank angle sensor and ECM
- Faulty bank angle sensor
- Faulty ECM

### DTC 54-1 (BANK ANGLE SENSOR LOW VOLTAGE)

#### 1. BANK ANGLE SENSOR SYSTEM INSPECTION

Erase the DTCs (page 4-8).

Check the bank angle sensor with the HDS pocket tester.

**Is about 0 V indicated?**

**YES** – GO TO STEP 2.

**NO** – Intermittent failure

#### 2. BANK ANGLE SENSOR POWER INPUT LINE OPEN INSPECTION

Turn the ignition switch OFF.

Disconnect the bank angle sensor 2P connector.

Turn the ignition switch ON.

Measure the voltage between the wire harness side bank angle sensor 2P connector terminal and ground.

**Connection: Black/blue – Ground (-)**

**Is there battery voltage?**

**YES** – GO TO STEP 3.

**NO** – Open circuit in the Black wire

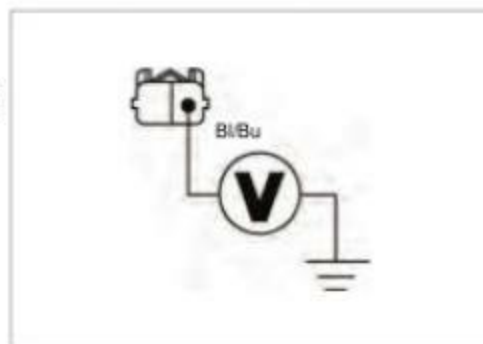

### 3. BANK ANGLE SENSOR OUTPUT LINE SHORT INSPECTION

Turn the ignition switch OFF.  
Disconnect the ECM 33P connector.  
Check for continuity between the wire harness side bank angle sensor 2P connector terminal and ground.

**Connection: Black/blue – Ground**

**Is there continuity?**

**YES** – Short circuit in the Black/blue wire

**NO** – GO TO STEP 4.

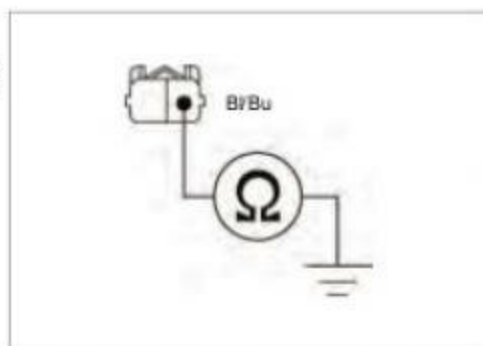

### 4. BANK ANGLE SENSOR OUTPUT LINE OPEN CIRCUIT INSPECTION

Disconnect the bank angle sensor connector.  
Check for continuity between the wire harness side ECM 33P connector and bank angle sensor 2P connector terminals.

**Connection: 26 – Black/blue**

**TOOL:**

**Test probe** 07ZAJ-RDJA110

**Is there continuity?**

**YES** – GO TO STEP 5.

**NO** – Open circuit in the Black/blue wire

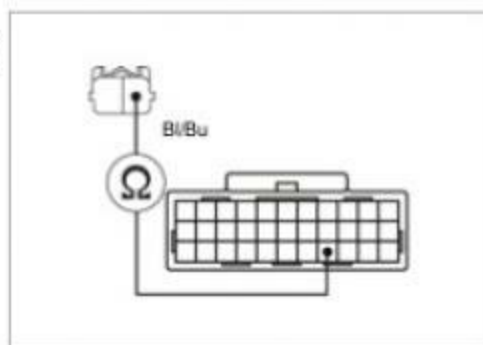

### 5. BANK ANGLE SENSOR INSPECTION

Replace the bank angle sensor with a known good one (page 4-27).  
Connect the bank angle sensor 2P connector and ECM 33P connector.  
Erase the DTCs (page 4-8).  
Check the bank angle sensor with the MCS.

**Is DTC 54-1 indicated?**

**YES** – Replace the ECM with a known good one, and recheck.

**NO** – Faulty original bank angle sensor

#### DTC 54-2 (BANK ANGLE SENSOR HIGH VOLTAGE)

##### 1. BANK ANGLE SENSOR SYSTEM INSPECTION

Erase the DTCs (page 4-8).  
Check the bank angle sensor with the MCS.

**Does the battery voltage exist?**

**YES** – GO TO STEP 2.

**NO** – Intermittent failure

**2. BANK ANGLE SENSOR INSPECTION**

Replace the bank angle sensor with a known good one (page 4-27).  
Erase the DTCs (page 4-8).  
Check the bank angle sensor with the MCS.

**Is DTC 54-2 indicated?**

**YES** – Replace the ECM with a known good one, and recheck.

**NO** – Faulty original bank angle sensor

**MIL CIRCUIT INSPECTION**

**WHEN THE IGNITION SWITCH IS TURNED ON, THE MIL DOES NOT COME ON**

Turn the ignition switch "OFF".  
Disconnect the ECM 33P (Black) connector (page 4-26).

Ground the ECM 33P (Black) connector terminal of the wire harness side with a jumper wire.

**CONNECTION: White/blue – Ground**

**TOOL:**

**Test probe** **07ZAJ-RDJA110**

Turn the ignition switch "ON", the MIL should come on.

- If the MIL comes on, replace the ECM with a new one, and recheck.
- If the MIL does not come on, check for open circuit in the White/blue wire between the speedometer and ECM.



**WHEN THE IGNITION SWITCH IS TURNED ON, THE MIL DOES NOT GO OFF WITHIN A FEW SECONDS (ENGINE STARTS)**

Turn the ignition switch "OFF".  
Disconnect the ECM 33P (Black) connector (page 4-26).

Turn the ignition switch "ON", the MIL should turn off.

- If the MIL comes on, check for short circuit in the White/blue wire between the speedometer and ECM.
- If the MIL turns off, check the following.

Check for continuity between the ECM 33P (Black) connector and ground.

**CONNECTION: Blue – Ground**

**STANDARD: No continuity**

**TOOL:**

**Test probe** **07ZAJ-RDJA110**

- If there is continuity, check for short circuit in the Blue wire between the DLC and ECM.
- If there is no continuity, replace the ECM with a new one, and recheck.

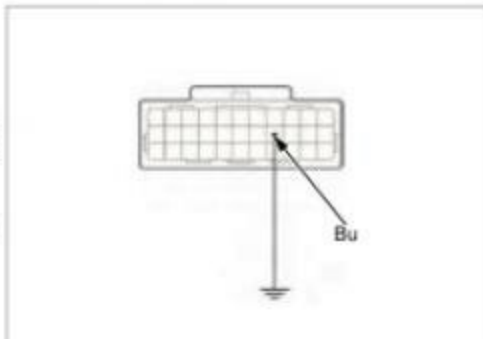

## TP SENSOR RESET PROCEDURE

### NOTE:

- Make sure that DTC is not stored in ECM. If the DTC is stored in ECM, TP sensor reset mode won't start by following the procedure below.
- Perform this procedure when throttle body is replaced with a new one.

1. Turn the ignition switch "OFF".

Remove the seat (page 2-3).

2. Remove the connector cover from the DLC and short the DLC terminals using the special tool (page 4-7).

3. Disconnect the EOT sensor 2P (Black) connector [1].

Short the wire side connector terminals with jumper wire.

**CONNECTION: Yellow/blue – Green/orange**

4. Turn the ignition switch "ON" then disconnect the jumper wire from the EOT sensor 2P (Black) connector while the MIL is blinking (reset receiving pattern) for 10 seconds.

5. Check if the MIL blinks.

After disconnection of the jumper wire, the MIL should start blinking. (successful pattern)

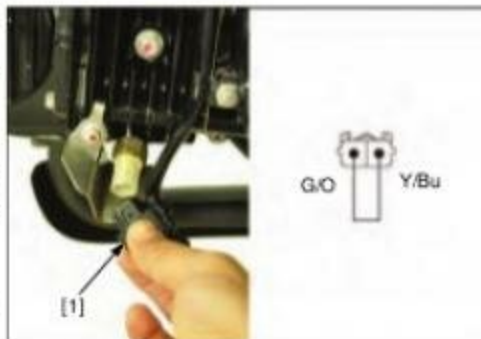

If the jumper wire is connected for more than 10 seconds, the MIL will stay "ON" (unsuccessful pattern). Try again from the step 3.

6. Turn the ignition switch "OFF".
7. Connect the EOT sensor 2P (Black) connector.

8. Disconnect the special tool from the DLC.

Install the dummy connector to the DLC.

9. Turn the idle air screw to specified opening (page 3-8).

10. If altitude is higher than 2,000 m, perform the altitude setting.

11. Check the engine idle speed (page 3-8).

Install the removed parts in the reverse order of removal.

## ECM INITIALIZING PROCEDURE

## NOTE:

- Make sure no DTC is stored in the ECM. If the DTC is stored in the ECM, ECM initializing mode won't start by following the procedure below.
- Perform this procedure when any of the following fuel related part is replaced with a new one.
  - Idle air screw
  - Fuel pump (page 7-5)
  - Fuel filter (page 7-5)
  - Fuel injector (page 7-9)
  - O<sub>2</sub> sensor (page 4-28)
- Perform this procedure when any of the following engine part is replaced or is overhauled.
  - Cylinder head (page 9-9)
  - Valves/valve guides/valve seats (page 9-9)
  - Cylinder/piston/piston rings (page 10-3)

1. Turn the ignition switch "OFF".  
Remove the seat (page 2-3).

Remove the connector cover from the DLC [1] and short the DLC terminals using the special tool [2] (page 4-7).

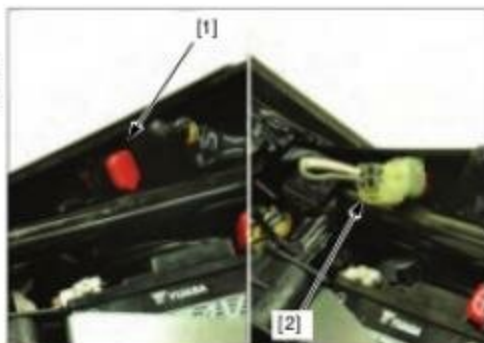

2. Open the throttle grip fully and hold.  
Turn the ignition switch "ON".

The MIL should come on and then start blinking rapidly.

Within 5 seconds after rapid blink starts, close the throttle grip and hold for more than 3 seconds.

## NOTE:

- If the MIL does not start blinking rapidly, turn the ignition switch "OFF" and try again.
- If you can not restart the procedure, recheck if the DTC is not stored in ECM.  
If the DTC is not stored but you still can not restart the procedure, replace the ECM with a known-good one and try again.

When the ECM initializing successfully, the MIL will repeat one short blink.

If the successful pattern is indicated, turn the ignition switch "OFF".

3. Disconnect the special tool from the DLC.  
Install the dummy connector to the DLC.
4. Turn the idle air screw to specified opening.
5. If altitude is higher than 2,000 m, perform the altitude setting (page 4-25).
6. Check the engine idle speed (page 3-8).  
Install the seat (page 2-3).

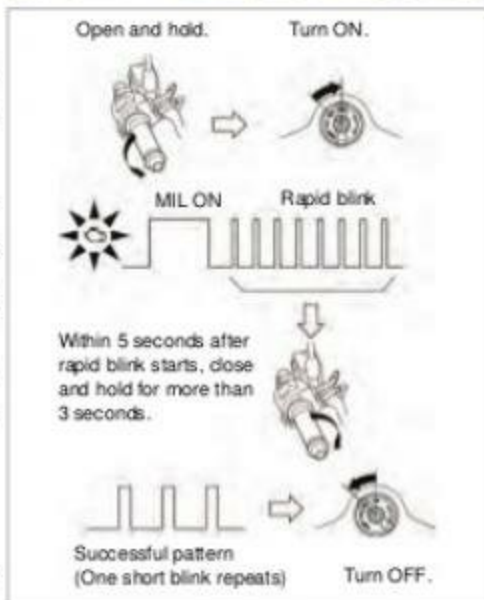

## ALTITUDE SETTING

- Make sure no DTC is stored in the ECM. If stored, the ECM cannot receive the setting mode.
- The setting will fail if the engine is started during the procedure.

Select the appropriate MODE which meets the situation described below.

- MODE 1: 0 - 2,000 m above sea level**  
**MODE 2: 2,000 - 2,500 m above sea level**  
**MODE 3: 2,500 - 3,500 m above sea level**  
**MODE 4: 3,500 m or higher above sea level**

Turn the ignition switch "OFF".

Remove the seat (page 2-3).

Remove the connector cover from the DLC and short the DLC terminals using the special tool (page 4-7).

Open the throttle grip fully and hold.

Turn the ignition switch "ON".

The MIL should come on and then start blinking rapidly.

**MODE 1:** Within 5 seconds after rapid blink starts, close the throttle grip and hold for more than 3 seconds.

**MODE 2, 3, 4:** Within 5 seconds after rapid blink starts, snap the throttle grip (close for 0.5 second/open for 0.5 second) as specified in the instructions to the right, then close and hold for more than 3 seconds.

**MODE 2: Snap 1 time**

**MODE 3: Snap 2 times**

**MODE 4: Snap 3 times**

### NOTE:

- If the MIL does not start blinking rapidly, turn the ignition switch "OFF" and try again.
- If you can not restart the procedure, recheck if a DTC is not stored in ECM.  
If a DTC is not stored but you still cannot restart the procedure, replace the ECM with a known-good one and try again.

The MIL will repeat short blinks matching a number of the selected MODE.

If the desired successful pattern is indicated, turn the ignition switch "OFF".

### NOTE:

- If the MIL starts blinking slowly during this step before a successful pattern is indicated, turn the ignition switch "OFF" and try again.
- If the number of MIL blinks and the number of desired MODE is different, turn the ignition switch "OFF" and try again.

Disconnect the special tool from the DLC.  
Install the dummy connector to the DLC.

Turn the idle air screw to specified opening and check the engine idle speed (page 3-8).

Install the seat (page 2-3).

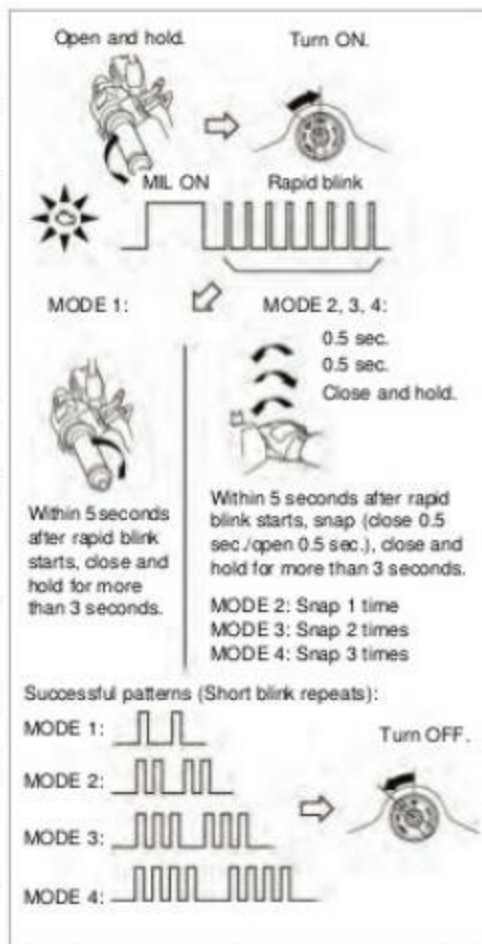

## ECM

## REMOVAL/ INSTALLATION

Remove the body cover (page 2-6).

Release the rubber band from the hooks.  
Disconnect the ECM 33P (Black) connector.

Installation is in the reverse order of removal.



## ECM POWER/GROUND LINE INSPECTION

## 1. ECM Ground Line Inspection

- Before starting the inspection, check for loose or poor contact on the ECM 33P (Black) connector and recheck the MIL blinking.
- Make sure that the battery is fully charged.

Turn the ignition switch "OFF".

Disconnect the ECM 33P (Black) connector (page 4-26).

Check for continuity between the ECM 33P connector [1] of the wire harness side and ground.

## TOOL:

Test probe 07ZAJ-RDJA110

CONNECTION: Green – Ground  
Green/black – Ground

*Is there continuity?*

YES – GO TO STEP 2.

NO – • Open circuit in Green wire.  
• Open circuit in Green/black wire.

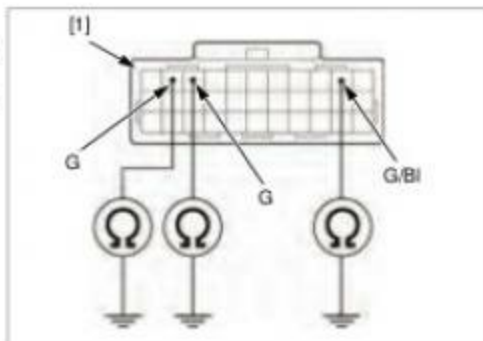

## 2. ECM Power Line Inspection

Turn the ignition switch "ON".

Measure the voltage between the ECM 33P (Black) connector [1] of the wire harness side and ground.

## TOOL:

Test probe 07ZAJ-RDJA110

CONNECTION: Black/blue (+) – Ground (-)

*Does the battery voltage exist?*

YES – Replace the ECM with a new one, and recheck.

NO – Open circuit in Black/blue wire.

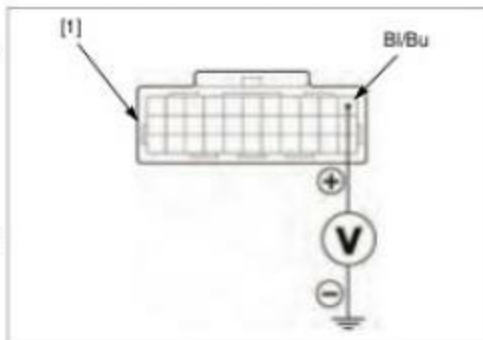

## EOT SENSOR

### REMOVAL/INSTALLATION

- Replace the EOT sensor while the engine is cold.
- Disconnect the EOT sensor 2P connector.  
Remove the EOT sensor [1] and sealing washer [2].
- Apply engine oil to the EOT sensor threads and seating surface then install a new sealing washer and EOT sensor.  
Tighten the EOT sensor to the specified torque.

**TORQUE: 14.5 N·m (1.5 kgf·m)**

- Connect the EOT sensor 2P connector.  
Fill the engine with recommended engine oil (page 3-7).

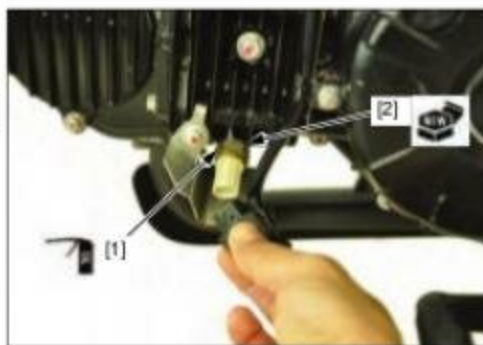

### INSPECTION

*Wear insulated gloves and adequate eye protection. Keep flammable material away from the burner.*

- Heat the water with an electric heating element.
- Suspend the EOT sensor [1] in heated water and check the continuity through the sensor as the water heats up.

#### NOTE:

- Soak the EOT sensor in water up to its threads with at least 40 mm from the bottom of the pan to the bottom of the switch.
- Keep temperature constant for 3 minutes before testing. A sudden change of temperature will result in incorrect readings. Do not let the thermometer EOT sensor touch the pan.

|             |              |                |
|-------------|--------------|----------------|
| Temperature | 20°C/68°F    | 100°C/212°F    |
| Resistance  | 2.5 – 2.8 kΩ | 0.21 – 0.22 kΩ |

- Replace the EOT sensor if it is out of specifications.  
Install the EOT sensor (page 4-27).

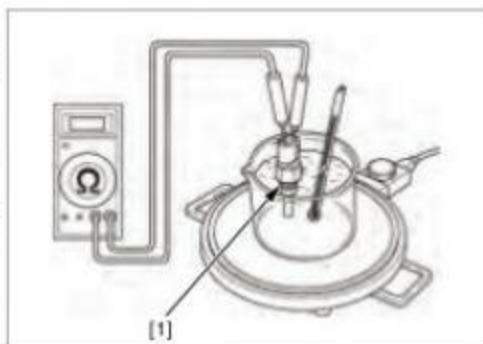

## BANK ANGLE SENSOR

### REMOVAL/INSTALLATION

- Remove the fuel tank (page 7-4).
- Disconnect the bank angle sensor connector [1].
- Remove the bank angle sensor mounting bolts [2] and bank angle sensor [3].
- Installation is in the reverse order of removal.



## O2 SENSOR

**NOTICE**

- If the O<sub>2</sub> sensor air hole or the inside of the O<sub>2</sub> sensor cap gets grease, oil, water or other materials on it, replace it with a new one and do not reuse.
- Do not apply any cleaning agent to the inside of the O<sub>2</sub> sensor cap when cleaning it.
- The O<sub>2</sub> sensor may be damaged if dropped. Replace it with a new one, if dropped.
- Perform the ECM initializing procedure if the O<sub>2</sub> sensor is replaced with a new one (page 4-24).

**REMOVAL**

Remove the right shroud (page 2-4).

Disconnect the O<sub>2</sub> sensor 1P connector and release the wire from the clamps.

Remove the bolt and O<sub>2</sub> sensor holder then remove the O<sub>2</sub> sensor cap [1] from the O<sub>2</sub> sensor.

Hold the center of the O<sub>2</sub> sensor cap [1] as shown. Disconnect the cap from the sensor while slightly turning it, less than 1/2 of a turn.

**NOTICE**

- Do not use pliers or other tools when disconnecting the O<sub>2</sub> sensor cap.
- Do not pull the O<sub>2</sub> sensor wire.

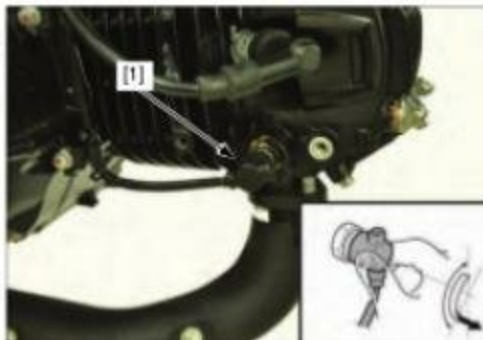

Remove the O<sub>2</sub> sensor while the engine is cold.

Remove the O<sub>2</sub> sensor.

- Do not use an impact wrench when removing or installing the O<sub>2</sub> sensor, or it may be damaged.

**INSTALLATION**

Install the O<sub>2</sub> sensor onto the cylinder head. Tighten the O<sub>2</sub> sensor to the specified torque.

**TORQUE: 24.5 N·m (2.5 kgf·m, 18 lbf·ft)**

Connect the O<sub>2</sub> sensor cap to the O<sub>2</sub> sensor by pushing it straight as shown.

**NOTICE**

- Be careful not to tilt the O<sub>2</sub> sensor cap when connecting the cap to the O<sub>2</sub> sensor.
- Make sure that the gap between the O<sub>2</sub> sensor and sensor cap is less than 2.0 mm.

Set the O<sub>2</sub> sensor holder while aligning its stopper with the cylinder head tab, then install and tighten the bolt.

Secure the wire with the clamps and connect the O<sub>2</sub> sensor 1P connector

- Perform the ECM initializing procedure if the O<sub>2</sub> sensor is replaced with a new one (page 4-24).

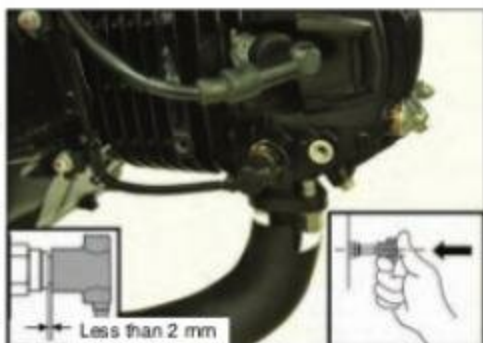

|                           |     |                                  |     |
|---------------------------|-----|----------------------------------|-----|
| SERVICE INFORMATION ..... | 5-2 | IGNITION SYSTEM INSPECTION ..... | 5-5 |
| TROUBLESHOOTING.....      | 5-3 | IGNITION COIL .....              | 5-7 |
| SYSTEM LOCATION.....      | 5-4 | IGNITION TIMING .....            | 5-8 |
| SYSTEM DIAGRAM .....      | 5-4 |                                  |     |

## IGNITION SYSTEM

### SERVICE INFORMATION

#### GENERAL

- When servicing the ignition system, always follow the steps in the troubleshooting (page 5-3).
- A faulty ignition system is often related to poorly connected or corroded connectors. Check those connections before proceeding.

#### SPECIFICATIONS

| ITEM                       |          | SPECIFICATIONS                |                 |
|----------------------------|----------|-------------------------------|-----------------|
| Spark plug                 | Standard | CPR6EA-9 (NGK)                | U20EPR9 (DENSO) |
|                            | Optional | CPR7EA-9 (NGK)                | U22EPR9 (DENSO) |
| Spark plug gap             |          | 0.8 – 0.9 mm (0.03 - 0.04 in) |                 |
| Ignition coil peak voltage |          | 100 V minimum                 |                 |
| CKP sensor peak voltage    |          | 0.7 V minimum                 |                 |
| Ignition timing            |          | 12° BTDC at idle speed        |                 |

#### TOOLS

|                                       |  |
|---------------------------------------|--|
| Peak Voltage Adaptor<br>07HGJ-0020100 | Pin Prove Male (2 pack)<br>07ZAJ-RDJA110 |
|---------------------------------------|--|

The image shows two diagnostic tools. On the left is a Peak Voltage Adaptor (07HGJ-0020100), which consists of a central rectangular unit with two cables extending from it, one ending in a spark plug boot and the other in a different connector. On the right is a Pin Prove Male (07ZAJ-RDJA110), which is a long, thin, cylindrical tool with a threaded end and a pointed tip.

## TROUBLESHOOTING

- Inspect the following before diagnosing the system.
  - Faulty spark plug
  - Loose spark plug cap or spark plug wire connection
  - Water got into the spark plug cap (Leaking the ignition coil secondary voltage)
- If there is no spark at cylinder, temporarily exchange the ignition coil with a known-good one and perform the spark test. If there is spark, the original ignition coil is faulty.
- "Initial voltage" of the ignition primary coil is the battery voltage with the ignition switch turned ON.

|                               | Unusual condition  | Probable cause (Check in numerical order)   |
|-------------------------------|--|---|
| Ignition coil primary voltage | No initial voltage with the ignition switch turned ON and engine stop switch "O" (Other electrical components are normal). | <ol style="list-style-type: none"> <li>Faulty ignition switch</li> <li>An open circuit in Black/blue wire between the ignition coil and engine stop switch</li> <li>An open circuit in Black/green or Black/red wires between the engine stop switch and ignition switch</li> <li>Loose or poor connection of the primary terminal, or an open circuit in the primary coil</li> <li>Faulty ECM (in case when the initial voltage is normal with the ECM connector disconnected).</li> <li>Faulty engine stop switch</li> </ol>  |
|                               | Initial voltage is normal, but it drops by 2 – 4 V while cranking the engine.  | <ol style="list-style-type: none"> <li>Incorrect peak voltage adaptor connections (System is normal if measured voltage is over the specifications with reverse connections).</li> <li>Battery is undercharged (Voltage drops largely when the engine is started).</li> <li>No voltage between the Black/blue (+) wire and body ground (-) at the ECM connector or poor connection of the ECM connector</li> <li>An open circuit or loose connection in Green or Green/black wire at the ECM</li> <li>An open circuit or loose connection in Green/red wire between the ignition coil and ECM</li> <li>Faulty sidestand switch or neutral switch or related wires</li> <li>Faulty CKP sensor (Measure peak voltage)</li> <li>Faulty ECM (in case when above No. 1 through 7 are normal).</li> </ol> |
|                               | Initial voltage is normal but there is no peak voltage while cranking the engine.  | <ol style="list-style-type: none"> <li>Incorrect peak voltage adaptor connections</li> <li>Faulty peak voltage adaptor</li> <li>Faulty CKP sensor</li> <li>Faulty ECM (in case when above No. 1 through 3 are normal).</li> </ol>   |
|                               | Initial voltage is normal but peak voltage is lower than the standard value.   | <ol style="list-style-type: none"> <li>The multimeter impedance is too low; below 10 MΩ/DCV.</li> <li>Cranking speed is too slow (Battery is undercharged).</li> <li>The sampling timing of the tester and measured pulse were not synchronized (System is normal if measured voltage is over the standard voltage at least once).</li> <li>Faulty ECM (in case when above No. 1 through 3 are normal).</li> </ol>  |
|                               | Initial and peak voltages are normal but no spark jumps.   | <ol style="list-style-type: none"> <li>Faulty spark plug or leaking ignition coil secondary current</li> <li>Faulty ignition coil</li> </ol>  |
| CKP sensor                    | Peak voltage is lower than standard value.   | <ol style="list-style-type: none"> <li>The multimeter impedance is too low; below 10 MΩ/DCV.</li> <li>Cranking speed is too low. (Battery is undercharged.)</li> <li>The sampling timing of the tester and measured pulse were not synchronized (System is normal if measured voltage is over the standard voltage at least once).</li> <li>Faulty CKP sensor (in case when above No.1 through 3 are normal).</li> </ol>  |
|                               | No peak voltage  | <ol style="list-style-type: none"> <li>Faulty peak voltage adapter</li> <li>Faulty CKP sensor</li> </ol>  |

# IGNITION SYSTEM

## SYSTEM LOCATION

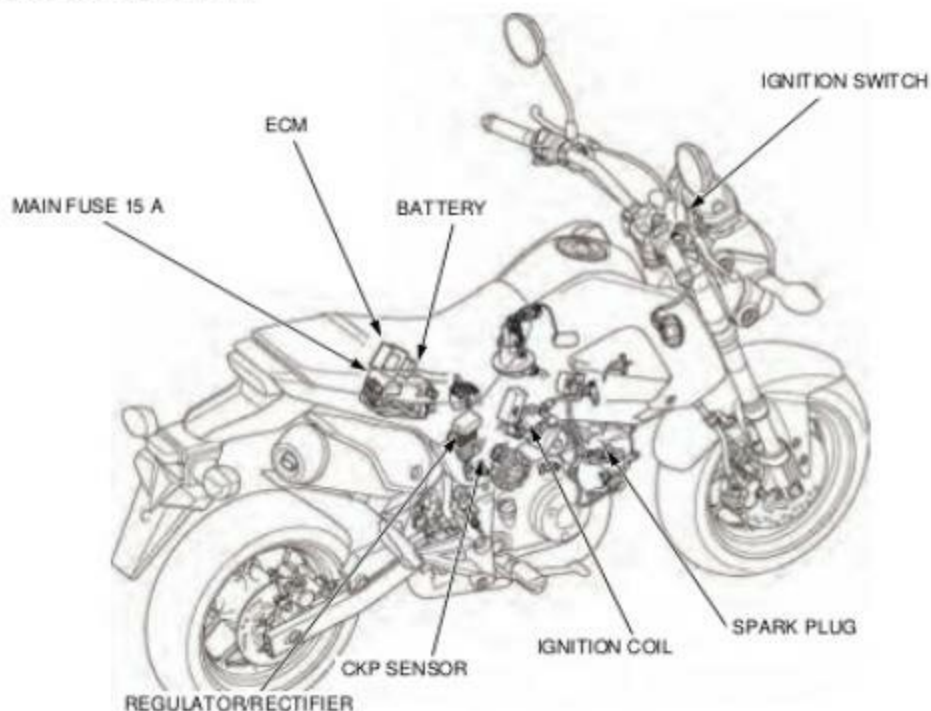

## SYSTEM DIAGRAM

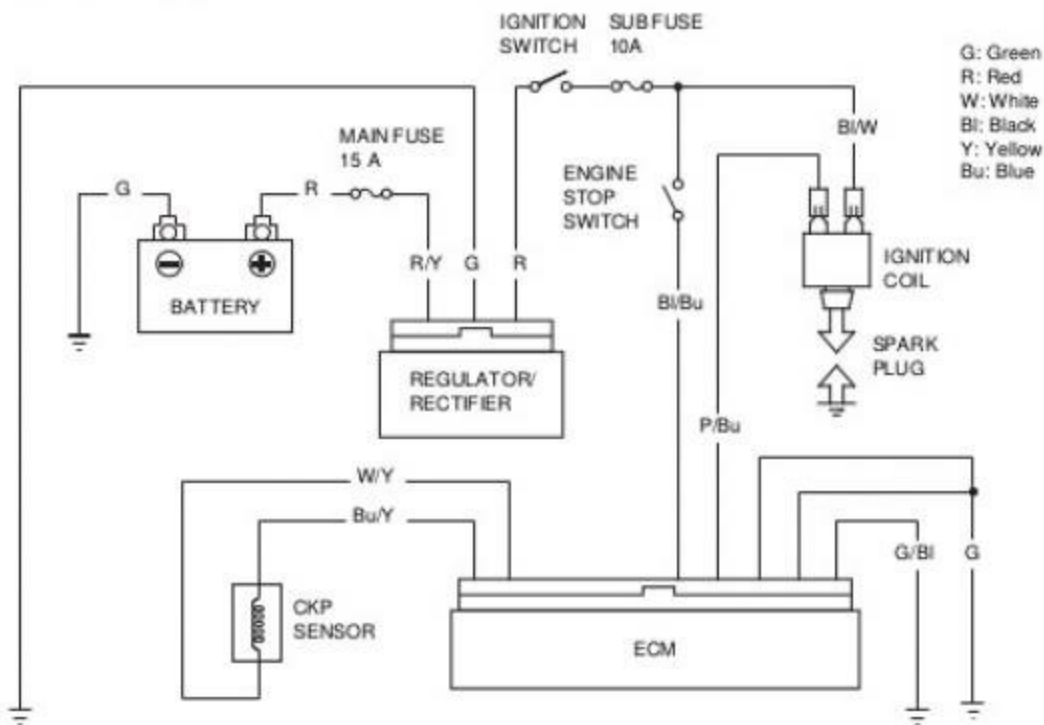

## IGNITION SYSTEM INSPECTION

### NOTE:

- If there is no spark at the spark plug, check all connections for loose or poor contact before measuring the peak voltage.
- Use a commercially available digital multimeter with an impedance of 10 M $\Omega$ /DCV minimum.
- The display value differs depending upon the internal impedance of the multimeter.
- If the Imrie diagnostic tester (model 625) is used, follow the manufacturer's instructions.

Connect the peak voltage adaptor [1] to the digital multimeter [2], or use the Imrie diagnostic tester.

### TOOLS:

Imrie diagnostic tester (model 625) or  
Peak voltage adaptor 07HGJ-0020100  
with commercially available digital multimeter  
(impedance 10 M $\Omega$ /DCV minimum)

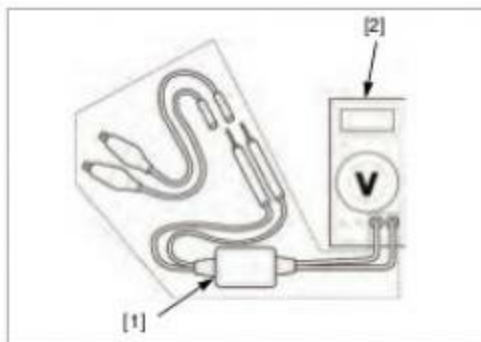

## IGNITION COIL PRIMARY PEAK VOLTAGE

### NOTE:

- Check all system connections before performing this inspection. Loose connectors can cause incorrect readings.
- Check cylinder compression and check that the spark plug is installed correctly.

Support the motorcycle with its sidestand.

Remove the right shroud (page 2-4).

Disconnect the spark plug cap [1] from the spark plug. Connect a known good spark plug [2] to the spark plug cap and ground the spark plug to the cylinder head as done in a spark test.

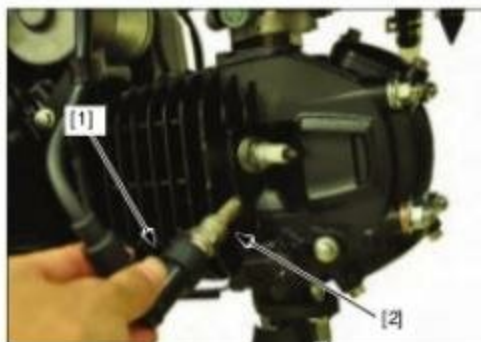

## IGNITION SYSTEM

*Do not disconnect the ignition coil primary wire.* With the ignition coil primary wire connected, connect the peak voltage adaptor or Imrie tester to the ignition coil primary terminal [1] and ground.

### TOOLS:

Imrie diagnostic tester (model 625) or  
Peak voltage adaptor 07HGJ-0020100  
with commercially available digital multimeter  
(impedance 10 M $\Omega$ /DCV minimum)

### CONNECTION:

Pink/blue terminal (+) – Body ground (-)

Turn the ignition switch ON.  
Shift the transmission into neutral.  
Check the initial voltage at this time.  
The battery voltage should be measured.  
If the initial voltage cannot be measured, follow the checks in the troubleshooting table (page 5-3).

*Avoid touching the spark plug and tester probes to prevent electric shock.*

Crank the engine with the electric starter with the throttle grip fully opened and read the ignition coil primary peak voltage.

### PEAK VOLTAGE: 100 V minimum

If the peak voltage is abnormal, refer to the troubleshooting on page 5-3.

Install the removed parts in the reverse order of removal.

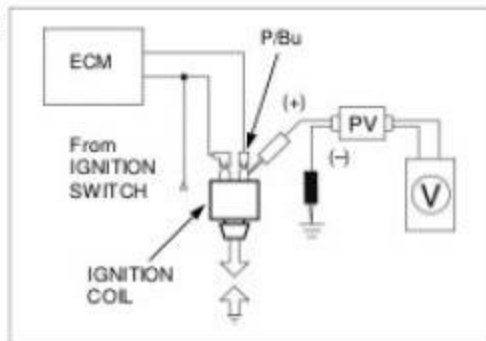

## CKP SENSOR PEAK VOLTAGE

### NOTE:

- Check cylinder compression and check that the spark plug is installed correctly.

Disconnect the ECM 33P (Black) connector.

Connect the peak voltage adaptor or Imrie diagnostic tester to the ECM 33P (Black) connector [1] terminals.

### TOOLS:

Imrie diagnostic tester (model 625) or  
Peak voltage adaptor 07HGJ-0020100  
with commercially available digital multimeter  
(impedance 10 M $\Omega$ /DCV minimum)  
Test probe 07ZAJ-RDJA110

CONNECTION: Blue/yellow (+) – White/yellow (-)

Turn the ignition switch ON and shift the transmission in neutral.

Crank the engine with the electric starter and measure the CKP sensor peak voltage.

### PEAK VOLTAGE: 0.7 V minimum

If the peak voltage measured at the ECM connector is abnormal, measure the peak voltage at the CKP sensor wire connectors.

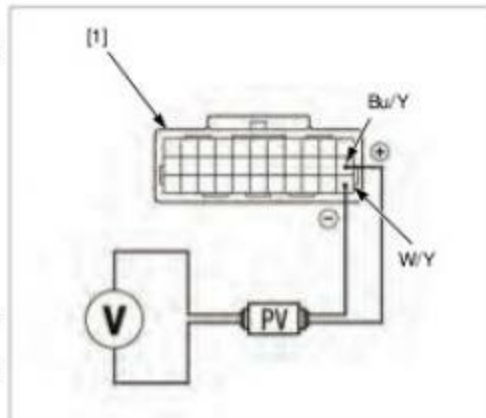

Turn the ignition switch OFF.

Disconnect the alternator 4P connector [1] and connect the peak voltage tester or adaptor probes to the connector terminals of the CKP sensor side.

**CONNECTION: Blue/yellow (+) – White/yellow (-)**

In the same manner as at the ECM 33P (Black) connector, measure the peak voltage and compare it to the voltage measured at the ECM 33P (Black) connector.

- If the peak voltage measured at the ECM is abnormal and the one measured at the CKP sensor is normal, the wire harness has an open circuit or loose connection.
- If the peak voltage of the CKP sensor side is lower than standard value, follow the checks described in the troubleshooting on page 5-3.

If the CKP sensor is faulty, replace the CKP sensor.

Install the removed parts in the reverse order of removal.

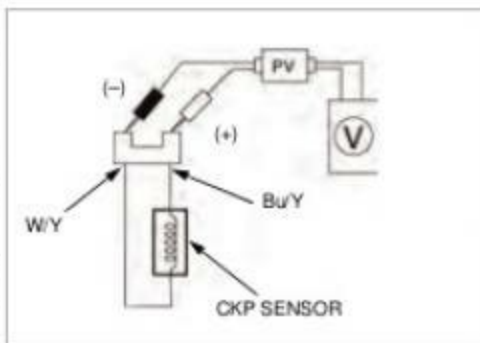

## IGNITION COIL

### REMOVAL/INSTALLATION

Remove the right shroud (page 2-4).

Disconnect the spark plug cap from the spark plug.

Disconnect the ignition coil wire connectors [1].  
Remove the bolts [2] and ignition coil [3].

Installation is in the reverse order of removal.

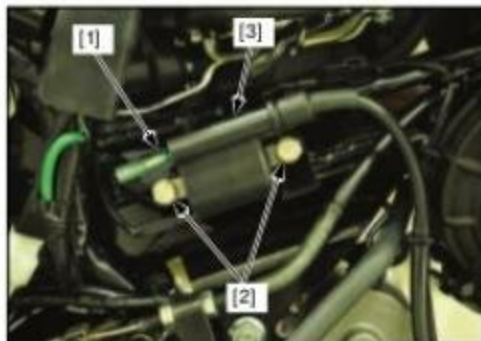

### IGNITION TIMING

- The ignition timing can not be adjusted since the ECM is factory preset.
- Before inspection, make sure that the engine idle speed is within specification (page 3-8). If not, adjust the idle air screw before proceeding.

Start the engine, let it idle until warmed up to the normal operating temperature.

*Read the manufacturer's instructions for timing light operation.*

Stop the engine and connect a timing light to the spark plug wire.

Remove the timing hole cap from the left crankcase cover.

Start the engine and let it idle.

**IDLE SPEED:  $1,400 \pm 100 \text{ min}^{-1}$  (rpm)**

If the engine idle speed is abnormal, inspect the idle air screw before proceeding.

The ignition timing is correct if the index notch [1] on the left crankcase cover aligns with the "F" mark [2] on the flywheel.

If the ignition timing is incorrect, perform the ECM initializing procedure (page 4-24) and recheck the ignition timing.

If the ignition timing is still incorrect, replace the ECM with a known-good one and recheck.

Apply engine oil to a new timing hole cap O-ring.

Install and tighten the timing hole cap to the specified torque.

**TORQUE: 6.0 N·m (0.6 kgf·m, 4.4 lbf·ft)**

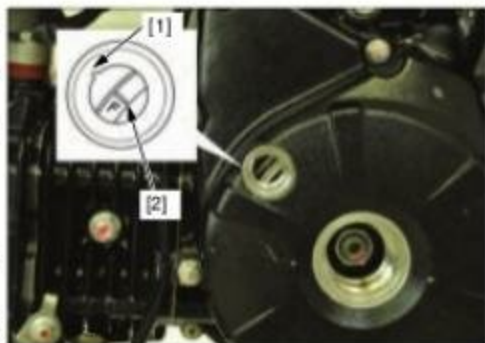

# 6. ELECTRIC STARTER SYSTEM

---

|                           |     |                     |     |
|---------------------------|-----|---------------------|-----|
| SERVICE INFORMATION ..... | 6-2 | SYSTEM DIAGRAM..... | 6-3 |
| TROUBLESHOOTING.....      | 6-2 | STARTER MOTOR ..... | 6-4 |
| SYSTEM LOCATION.....      | 6-3 | STARTER RELAY.....  | 6-9 |

## ELECTRIC STARTER SYSTEM

### SERVICE INFORMATION

#### GENERAL

- A weak battery may be unable to turn the starter motor quickly enough, or supply adequate ignition current.
- When checking the starter system, always follow the steps in the troubleshooting.

#### SPECIFICATIONS

Unit: mm (in)

| ITEM                       | STANDARD                | SERVICE LIMIT |
|----------------------------|-------------------------|---------------|
| Starter motor brush length | 6.7 – 7.3 (0.26 - 0.29) | 3.5 (0.14)    |

#### TROUBLESHOOTING

| Unusual condition |   | Probable cause (Check in numerical order)  |
|-------------------|---|--|
| Starter motor     | Starter motor does not turn   | <ol style="list-style-type: none"><li>1. Loose or poor contact on related connectors and terminals</li><li>2. Fuse</li><li>3. Weak battery</li><li>4. Faulty starter relay switch</li><li>5. Faulty starter motor</li><li>6. Loose connection, open or short circuit in starter motor cable</li><li>7. Faulty starter switch</li><li>8. Open circuit in starter relay switch ground circuit</li><li>9. Open or short circuit in starter relay switch power circuit<ul style="list-style-type: none"><li>- Faulty engine stop switch</li><li>- Faulty clutch switch</li><li>- Faulty neutral switch</li><li>- Faulty neutral diode</li></ul></li><li>10. Loose contact or open circuit in related wires</li></ol> |
|                   | Starter motor turns only when the transmission is in neutral (Starter motor does not turn when the transmission is in any gear with the sidestand retracted and clutch lever pulled in)                           | <ol style="list-style-type: none"><li>1. Loose or poor contact on related connectors and terminals</li><li>2. Faulty clutch switch</li><li>3. Loose contact or open circuit in related wires</li></ol>   |
|                   | Starter motor turns only when the transmission is in any gear with the sidestand retracted and clutch lever pulled in (Starter motor does not turn when the transmission is in neutral and clutch lever released) | <ol style="list-style-type: none"><li>1. Loose or poor contact on related connectors and terminals</li><li>2. Faulty neutral diode</li><li>3. Faulty neutral switch</li><li>4. Loose contact or open circuit in related wires</li></ol>  |
|                   | Starter motor turns slowly  | <ol style="list-style-type: none"><li>1. Low battery voltage</li><li>2. Poorly connected battery terminal cable</li><li>3. Poorly connected starter motor cable</li><li>4. Faulty starter motor</li><li>5. Poorly connected battery ground cable</li></ol>   |
|                   | Starter motor turns, but engine does not turn   | <ol style="list-style-type: none"><li>1. Starter motor is running backwards<ul style="list-style-type: none"><li>- Case assembled improperly</li><li>- Terminals connected improperly</li></ul></li><li>2. Faulty starter clutch</li><li>3. Damaged or faulty starter idle gear and/or reduction gear</li></ol>  |
|                   | Starter relay switch "Clicks", but engine does not turn over  | <ol style="list-style-type: none"><li>1. Crankshaft does not turn due to engine problems</li></ol>   |

## SYSTEM LOCATION

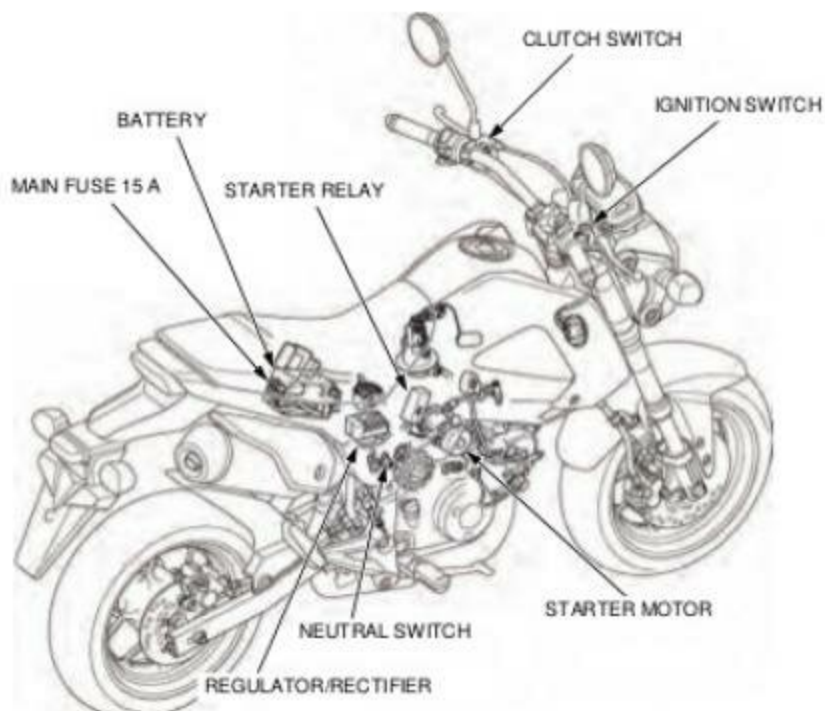

## SYSTEM DIAGRAM

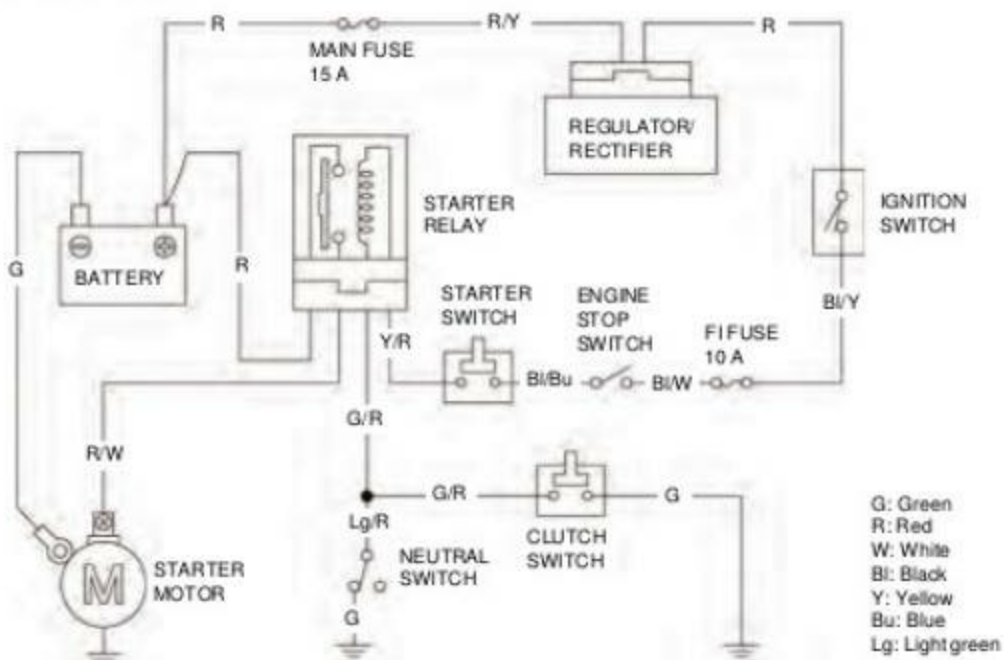

### STARTER MOTOR

#### REMOVAL/INSTALLATION

Remove the right shroud (page 2-3).

Remove the rubber cap and terminal nut [1], then disconnect the starter motor cable.

Remove the bolts [2], ground cable [3] and starter motor from the engine.

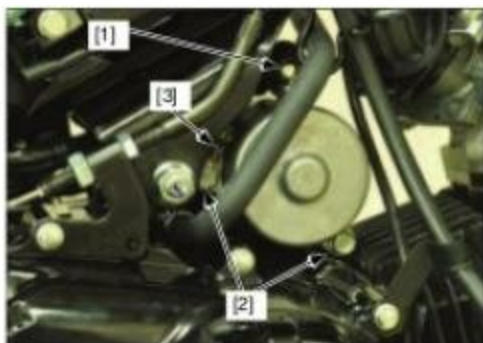

Remove the O-ring [1] from the starter motor.

Installation is in the reverse order of removal.

**TORQUE: Starter motor terminal nut**  
**7.0 N·m (0.7 kgf·m, 5.2 lbf·ft)**

- Replace the O-ring with a new one.
- Apply engine oil to the O-ring surface.



**DISASSEMBLY**

Remove the following:

- Bolts [1]/O-rings [2]
  - Front cover [3]/lock washer [4]/insulator [5]/shims [6]/seal ring [7]
  - Rear cover [8]/shims/seal ring/armature [9]/motor case [10]
  - Brush springs [11]/screws [12]/washers [13]/brush [14]/brush holder [15]/insulator plates [16]
  - Nut [17]/washer [18]/insulators [19]/O-ring [20]/brush set plate [21]/brush [22]
- Record the location and number of shims.

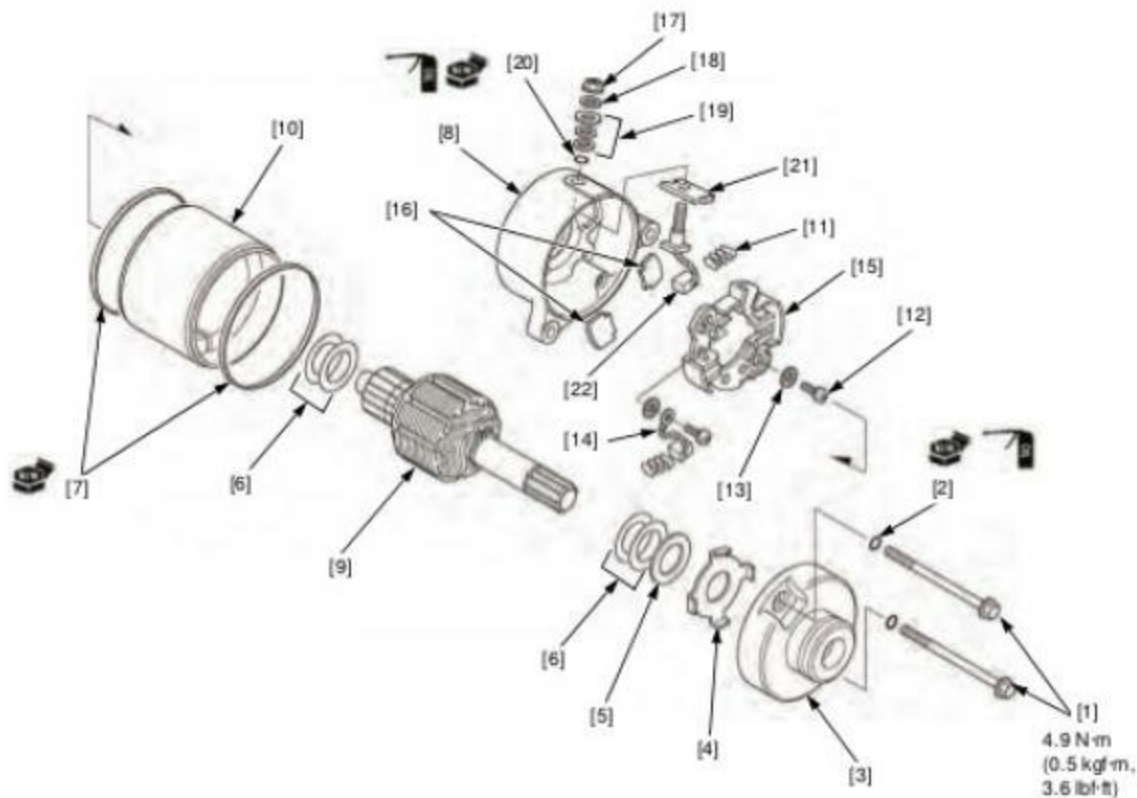
**ASSEMBLY**

Install the brush [1] and brush set plate [2] into the rear cover.



## ELECTRIC STARTER SYSTEM

Install the insulator plates [1] onto the rear cover [2].

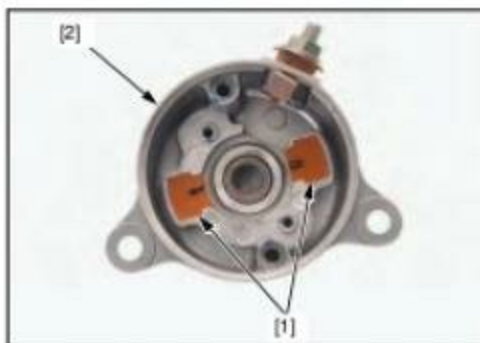

Install the brush holder [1], brush [2], washers [3] and screws [4] into the rear cover [5] as shown.

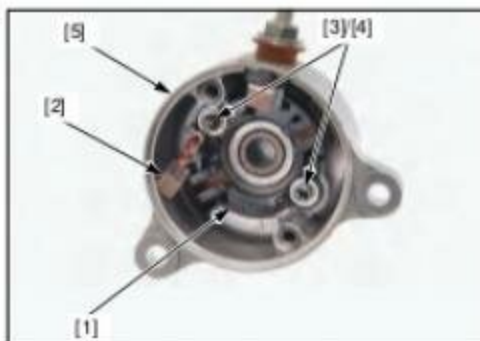

Apply oil to the oil seal lips [1].

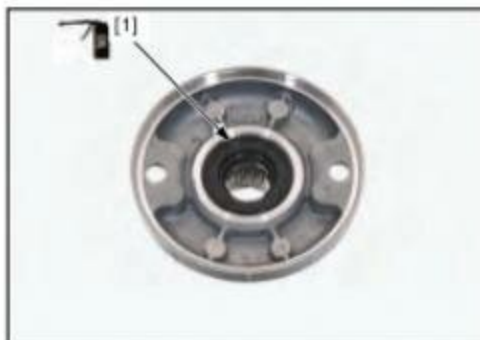

Install the armature [1] into the motor case [2] while holding the armature shaft tightly to keep the magnet of the motor case from pulling the armature shaft against it.

### NOTICE

*The coil may be damaged if the magnet pulls the armature against the motor case.*



Install the springs [1] and brushes [2] to the brush holder [3].

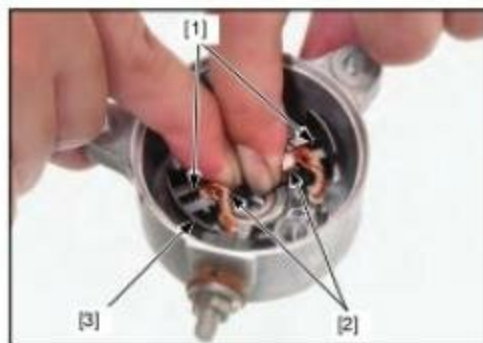

Install a new seal ring [1].

*Install the same number of shims in the same locations as noted during disassembly.*

Install the shims [2] onto the armature shaft.

Install the rear cover [3] while pushing the brushes into the brush holder and aligning the brush set plate tab with the motor case groove.

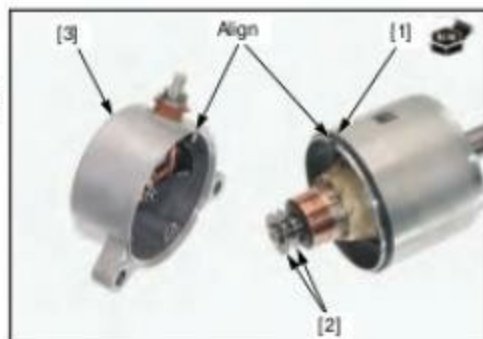

*Install the same number of shims in the same locations as noted during disassembly.*

Install the shims [1], insulator [2] and a new seal ring [3].

Install the lock washer [4] to the front cover [5].

Install the front cover.

- When installing the front cover, take care to prevent damaging the oil seal lip with the armature shaft.

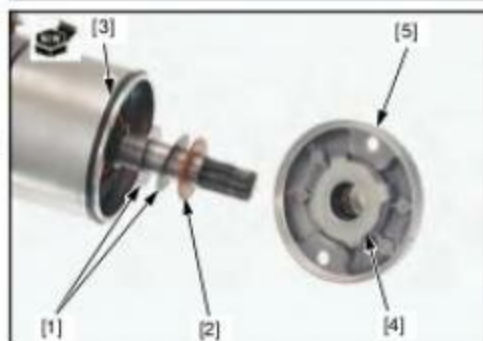

Align the index lines on the covers and motor case.

Apply oil to new O-rings [1] and install them onto the motor case bolts [2].

Install and tighten the starter motor case bolts to the specified torque.

**TORQUE: 4.9 N·m (0.5 kgf·m, 3.6 lbf·ft)**

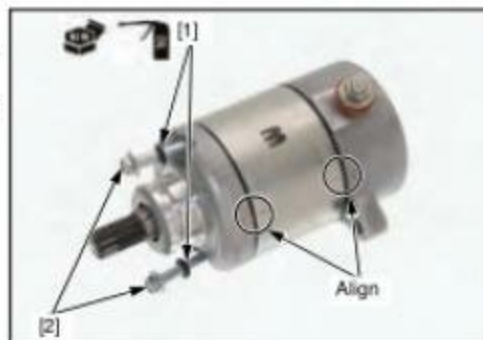

## ELECTRIC STARTER SYSTEM

### INSPECTION

Check the oil seal [1] of the front cover [2] for deterioration or damage, and needle bearing [3] for wear or damage.

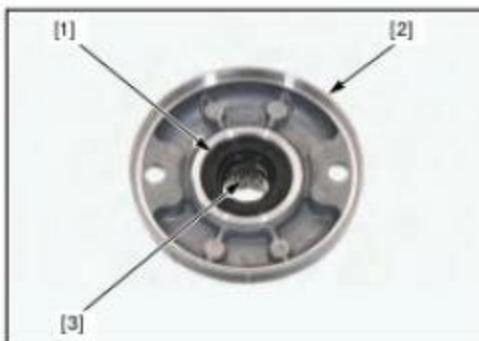

Check the commutator bars [1] of the armature [2] for discoloration, wear or damage.

*Do not use emery or sand paper on the commutator.*

Clean the metallic debris off between commutator bars.  
Replace the armature with a new one if necessary.

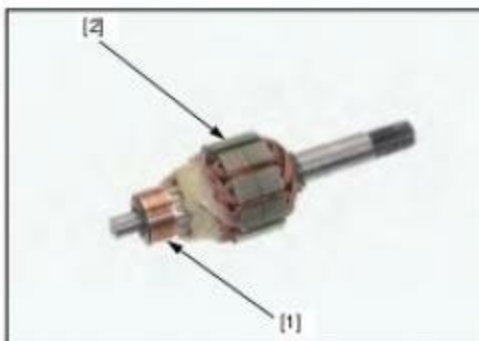

Check for continuity between pair of commutator bars [1].  
There should be continuity.

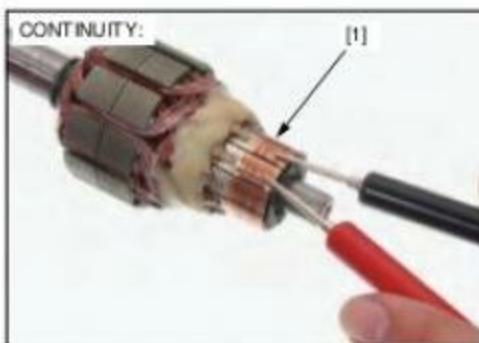

Check for continuity between each commutator bar [1] and the armature shaft [2].  
There should be no continuity.

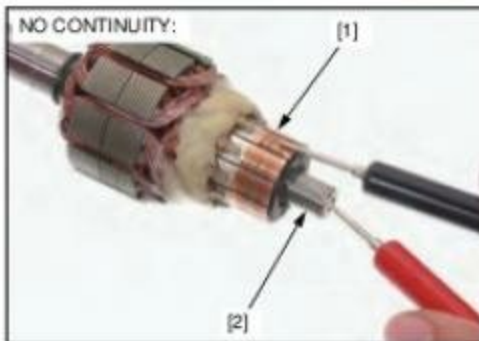

Check for continuity between the insulated brush [1] and cable terminal [2]. There should be continuity.

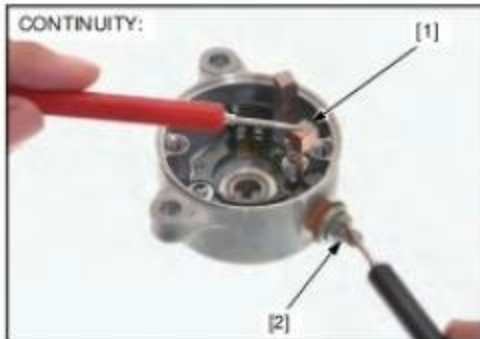

Check for continuity between the insulated brush [1] and rear cover [2]. There should be no continuity.

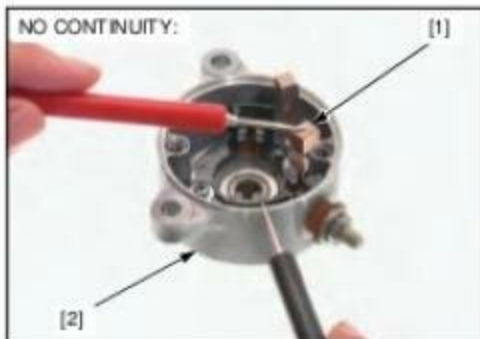

## STARTER RELAY

### REMOVAL/INSTALLATION

Remove the right shroud (page 2-4).

Remove the starter relay [1] from the stay.  
Disconnect the starter relay 5P connector [2].  
Installation is in the reverse order of removal.

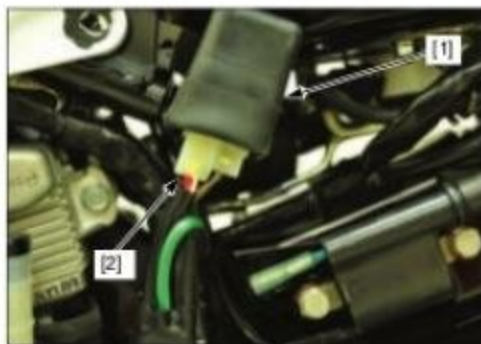

### OPERATION INSPECTION

Remove the right shroud (page 2-4).

Turn the ignition switch "ON".

Push the starter switch.

The system is normal if the starter relay clicks.

If you hear the relay "CLICK", but starter does not turn or if you don't hear the relay "CLICK", inspect the starter relay continuity (page 6-10).

## ELECTRIC STARTER SYSTEM

### STARTER GROUND LINE CIRCUIT INSPECTION

Remove the starter relay (page 6-9).

Measure the continuity between the starter relay 5P connector [1] of the wire harness side and ground

**CONNECTION: Yellowed (+) – Ground (-)**

If the continuity appears only when the clutch lever pulled or transmission is in neutral, the circuit is normal.

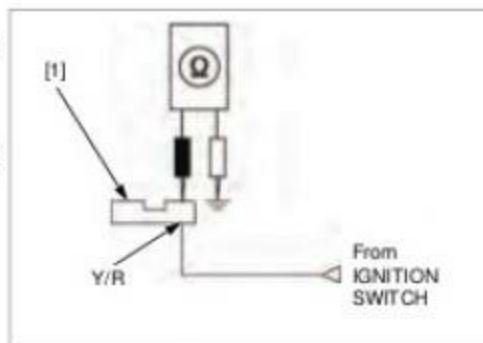

### STARTER POWER LINE INSPECTION

Remove the starter relay (page 6-9).

Turn the ignition switch "ON" and engine stop switch "O".

Measure the Voltage between the starter relay 5P connector [1] of the wire harness side and ground.

**CONNECTION: Black/blue – Ground**

If the battery voltage appears only when the starter switch is pressed, the circuit is normal.

If the voltage not appears, inspect the following:

- Starter switch
- Ignition switch
- Engine stop switch

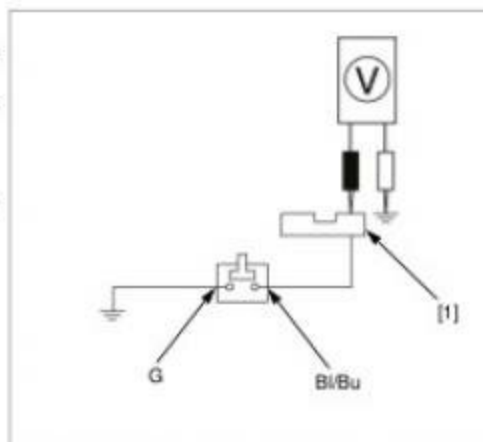

### STARTER RELAY CONTINUITY INSPECTION

Remove the starter relay (page 6-9).

Connect a fully charged 12 V battery positive wire to the relay switch terminal A and negative wire to the terminal B.

Check for continuity at the terminal C and terminal D.

There should be continuity between the C and D terminals while the battery is connected, and no continuity when the battery is disconnected.

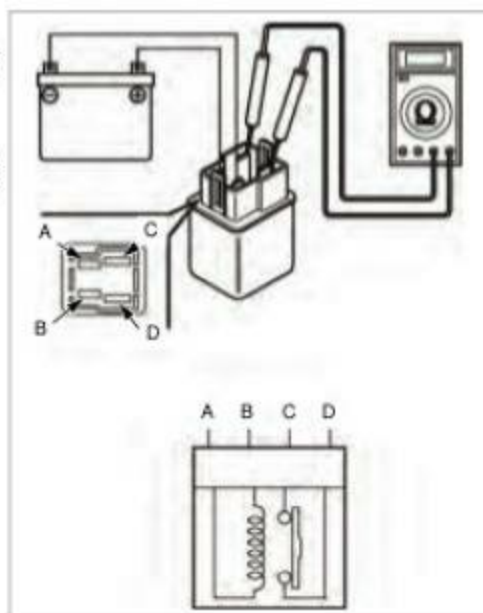

|                                  |     |  |      |
|----------------------------------|-----|--|------|
| SERVICE INFORMATION .....        | 7-2 | THROTTLE BODY .....                        | 7-8  |
| FUEL LINE INSPECTION .....       | 7-3 | FUEL INJECTOR .....                        | 7-9  |
| FUEL TANK .....                  | 7-4 | EVAP PURGE CONTROL<br>SOLENOID VALVE ..... | 7-10 |
| FUEL FILTER/FUEL PUMP UNIT ..... | 7-5 | EVAP CANISTER .....                        | 7-11 |
| AIR CLEANER HOUSING .....        | 7-7 |  |      |

## FUEL SYSTEM

# SERVICE INFORMATION

### GENERAL

- Work in a well ventilated area. Smoking or allowing flames or sparks in the work area where gasoline is stored can cause a fire or explosion.
- Do not snap the throttle valve from full open to full close after the throttle cable has been removed. It may cause incorrect idle operation.
- Seal the intake port with tape or a clean cloth to keep dirt and debris from entering the engine after the throttle body has been removed.
- Do not damage the throttle body. It may cause incorrect throttle valve operation.
- Prevent dirt and debris from entering the throttle bore and air passages after the throttle body has been removed. Clean them using compressed air if necessary.
- Do not loosen or tighten the white painted nut and screw of the throttle body. Loosening or tightening them can cause throttle valve and idle control failure.

### SPECIFICATIONS

| ITEM                                | SPECIFICATIONS  |
|-------------------------------------|---|
| Throttle body identification number | GQY9A   |
| Idle air screw standard opening     | 2 turns out from the fully seated position                    |
| Throttle grip freeplay              | 2 – 6 mm (0.08 - 0.24 in)                                     |
| Fuel pressure at idle               | 270 - 323 kPa (2.75 - 3.29 kgf/cm <sup>2</sup> , 39 - 47 psi) |
| Fuel pump flow (at 12 V)            | 162 cm <sup>3</sup> minimum/10 seconds                        |

### TORQUE VALUES

#### FUEL SYSTEM

| ITEM                                | Q'TY | THREAD DIA. (mm) | TORQUE N-m (kgf-m, lbf-ft) | REMARKS                              |
|-------------------------------------|------|------------------|----------------------------|--------------------------------------|
| Fuel filter stay nut                | 2    | 6                | 12 (1.2, 9)                | For tightening sequence See page 7-5 |
| Fuel pump setting plate nut         | 2    | 6                | 12 (1.2, 9)                |                                      |
| Fuel pump setting plate special nut | 2    | 6                | 12 (1.2, 9)                |                                      |
| Throttle cable stay screw           | 1    | 5                | 3.4 (0.3, 2.5)             |                                      |
| Connecting hose band screw          | 1    | 4                | 1.5 (0.2, 1.1)             |                                      |

### TOOLS

Fuel Pressure Gauge Attachment Set  
070MJ-K260100

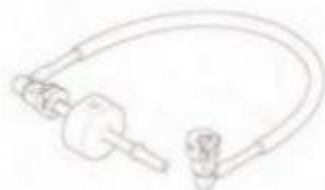

Fuel Adapter Male "B" 07AAJ-S6MA200, quantity 2. Use with fuel line P/N: 17570-K26-901 (U.S.A. only)

Fuel Pressure Gauge Set  
07406-0040004



07406-004000C or 07406-004000B (U.S.A. only)

## FUEL LINE INSPECTION

Check the fuel feed hose and quick connect fittings connecting area for deterioration, damage or leakage. Replace the fuel line if necessary.

Check the fuel pump unit mounting area for leakage. Replace the fuel pump packing and/or O-ring if necessary (page 7-5).

### FUEL PRESSURE TEST

Remove the left shroud (page 2-4).

Relieve the fuel pressure (page 7-4) and disconnect the fuel injector side quick connect fitting.

Attach the fuel pressure gauge, attachments.

#### TOOLS:

[1]: Fuel pressure gauge 07406-0040004  
[2]: Pressure gauge attachment 070MJ-K260100

#### U.S.A. TOOLS:

Fuel Pressure Gauge, 0-0100 psi 07406-004000C or 07406-004000B

Fuel Adapter Male "B" 07AAJ-S6MA200, quantity 2. Use with fuel line P/N: 17570-K26-901 (U.S.A. only)

Temporarily connect the fuel pump 5P connector and battery cables.

Start the engine and let it idle.

Read the fuel pressure.

**STANDARD: 270 – 323 kPa**  
(2.75 - 3.29 kgf/cm<sup>2</sup>, 39 - 47 psi)

If the fuel pressure is out of specified, inspect the following:

- Fuel line (page 7-3)
- Fuel pump unit (page 7-5)
- Fuel filter (page 7-5)

After inspection, relieve the fuel pressure (page 7-4).

Remove the special tools from the fuel pump.

Connect the quick connect fitting (page 7-5).

### FUEL FLOW INSPECTION

Relieve the fuel pressure (page 7-4) and disconnect the fuel injector side quick connect fitting (page 7-5).

*Wipe off spilled out gasoline.*

Place the end of the fuel hose into an approved gasoline container.

Temporarily connect the fuel pump 5P connector and battery cables.

Turn the ignition switch ON.

Measure the amount of fuel flow.

#### NOTE:

- The fuel pump operates for 2 seconds. Repeat 5 times to obtain the total measuring time.
- After the test, return the fuel to the fuel tank.

#### Amount of fuel flow:

**162 cm<sup>3</sup> minimum/10 seconds**

If fuel flow is less than specified, inspect the following:

- Fuel pump unit (page 7-5)
- Fuel filter (page 7-5)

Connect the quick connect fitting (page 7-5).



### FUEL TANK

#### REMOVAL/INSTALLATION

- Before disconnecting fuel feed hose, relieve pressure from the system by following the procedures below.
- This motorcycle uses resin in the manufacture of the fuel feed hose. Do not bend or twist the fuel feed hose.

Turn the ignition switch OFF.

To relieve the fuel pressure, start the engine and disconnect the fuel pump connector.

Disconnect the battery negative (-) cable.

Remove the following:

- Shroud (page 2-4).
- Fuel tank cover (page 2-6).

Remove the bolts [1],[2] and nuts [3].

Release the fuel tank from the frame.

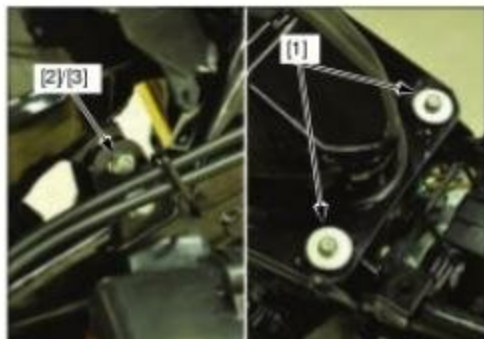

Disconnect the fuel pump 5P connector [1].

Check the fuel quick connect fitting [1] for dirt, and clean if necessary.

*Place a shop towel over the quick connect fitting.*

Disconnect the fuel feed hose [2] (page 7-5).

Install the removed parts in the reverse order of removal.

#### NOTE:

- The fuel pump will run for about 2 seconds, and fuel pressure will rise.
- Repeat 2 or 3 times, and check that there is no leakage in the fuel supply system.

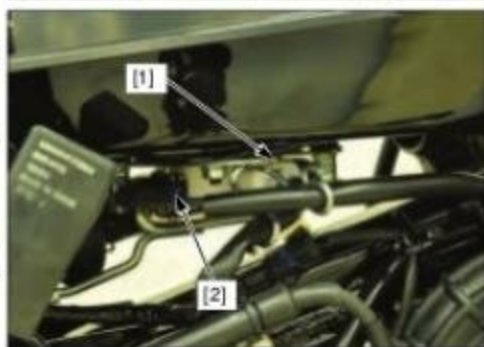

**QUICK CONNECT FITTING****REMOVAL**

1. Push the retainer [1] forward.
2. Press down the retainer [1] and hold.  
Disconnect the connector [2] from the fuel pump joint/ fuel injector joint.  
Check the retainer condition and replace it if necessary.
  - Prevent the remaining fuel in the fuel feed hose from flowing out, using a shop towel.
  - Be careful not to damage the hose or other parts.
  - Do not use tools.
  - If the connector does not move, alternately pull and push the connector until it comes off easily.
3. To prevent damage and keep foreign matter out, cover the disconnected connector and pipe end with the plastic bags.

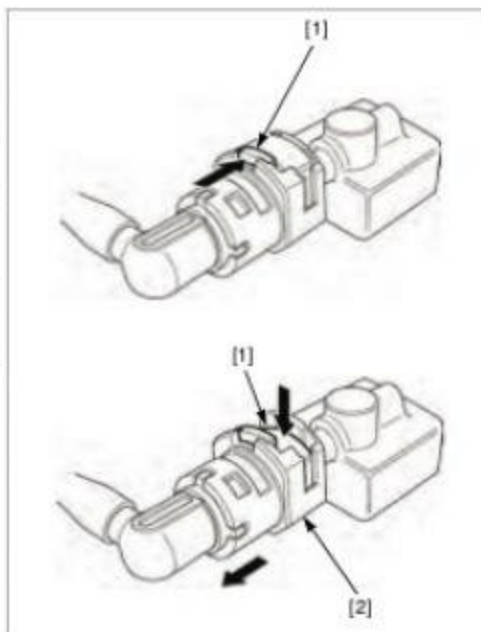
**INSTALLATION**

1. Press the connector [1] onto the fuel pump joint/fuel injector joint until the retainer [2] locks with a "CLICK".
  - Align the quick connect fitting with the pipe.  
If it is hard to connect, put a small amount of engine oil on the pipe end.
2. Make sure the connection is secure; check visually and by pulling the connector.

Fuel pump side shown:

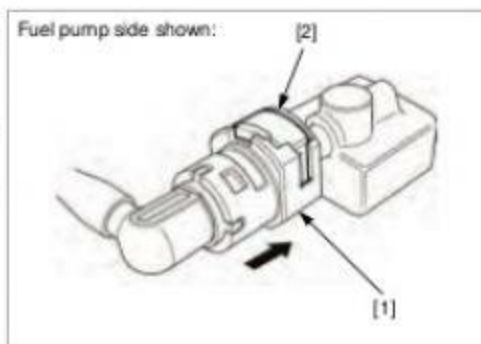
**FUEL FILTER/FUEL PUMP UNIT****REMOVAL**

- Clean around the fuel pump.
- Remove the fuel tank (page 7-4).
- Disconnect the fuel hoses [1] and remove the fuel filter.
- Remove the nuts [2] and fuel pump guard.

*Place a shop towel over the fuel hose.*

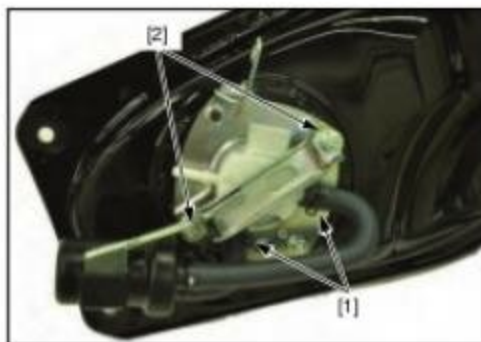

## FUEL SYSTEM

Loosen the four nut [1], washer [2], cap nut [3] and special nuts [4] in a criss-cross pattern in several steps.

Remove the nuts and set plates.

Remove the fuel pump.

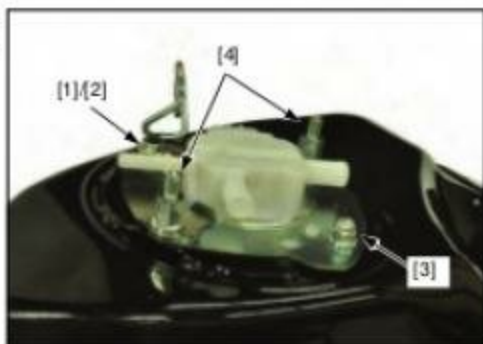

Remove the outer packing [1] and inner packing [2] from the fuel pump unit grooves.

### INSTALLATION

Install a new inner packing onto the fuel pump unit groove.

Install a new outer packing onto the fuel pump unit groove by aligning the tab with the boss of the fuel pump unit.

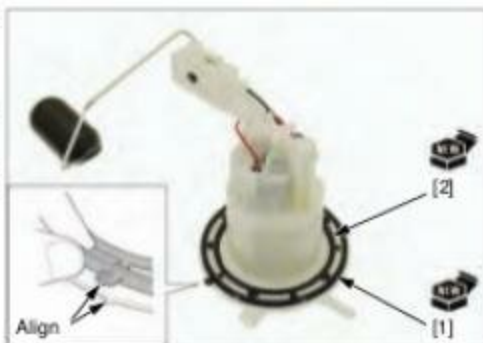

Apply engine oil to the fuel pump packings seating area of the fuel tank.

Set the setting plates [1] onto the fuel pump [2] by aligning the hole and boss.

Install fuel pump into the fuel tank by aligning the triangle marks of the setting plate and fuel tank.

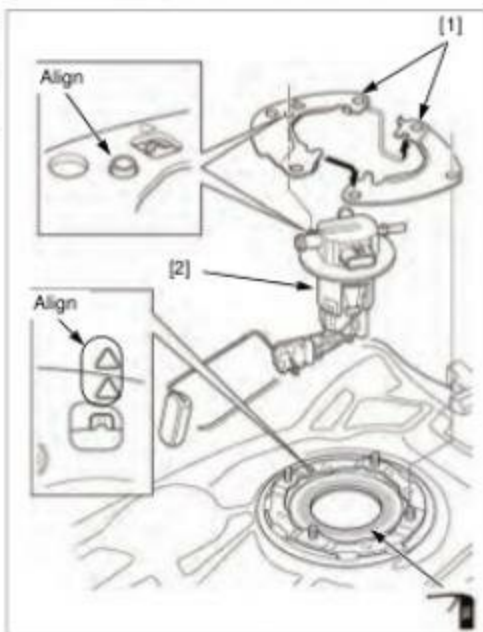

See from the check hole, check that the outer packing [1] is installed properly.

Install and temporarily tighten the nut, washer, cap nut and special nuts.

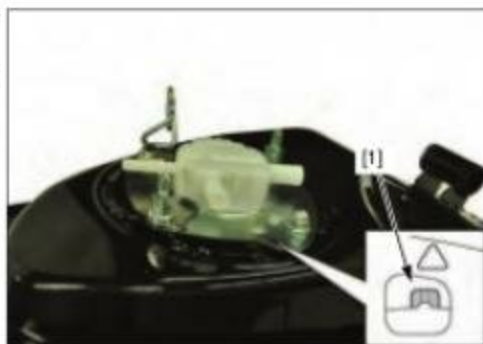

Tighten the nuts and special nuts to the specified torque in the specified sequence as shown.

**TORQUE: 12 N·m (1.2 kgf·m, 9 lbf·ft)**

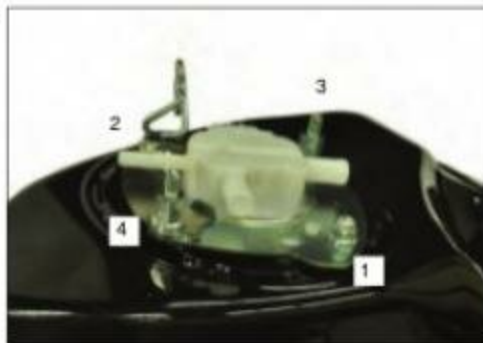

Install the fuel filter stay [1] and two nuts [2].

Tighten the nuts [2] to the specified torque while holding the special nut [3] securely.

**TORQUE: 12 N·m (1.2 kgf·m, 9 lbf·ft)**

Install the fuel filter assembly.

- Perform the ECM initializing procedure (page 4-24) if the fuel pump unit is replaced with a new one.

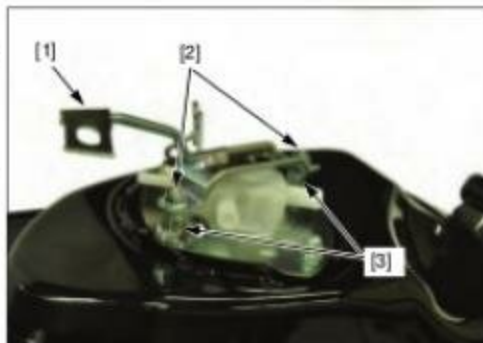

## AIR CLEANER HOUSING

### REMOVAL/INSTALLATION

Remove the shroud (page 2-4).

Disconnect the IAT sensor connector [1].



## FUEL SYSTEM

Disconnect the crankcase breather hose [1] and fuel breather hose [2].

Loosen the connecting hose band screw [3] and disconnect the connecting hose from the throttle body.

Remove the bolts [4] and release the tab [5] from the air cleaner housing stay.

Installation is in the reverse order of removal.

### NOTE:

Connect the connecting hose to the throttle body while aligning its groove with the boss of the throttle body.

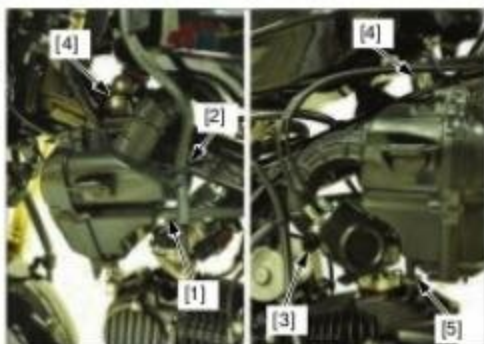

## THROTTLE BODY

### REMOVAL

- If the throttle body is to be disassembled, or replaced with a new one, perform the TP sensor reset procedure (page 4-23).

Remove the shroud (page 2-4).

Remove the bolt and the throttle drum cover.

Loosen the throttle cable lock nut [1]. Remove the throttle cable from the cable bracket and throttle drum.

Loosen the connecting hose band screw [2] and disconnect the air cleaner connecting hose.

*Be careful not to damage the threads of the throttle cable.*

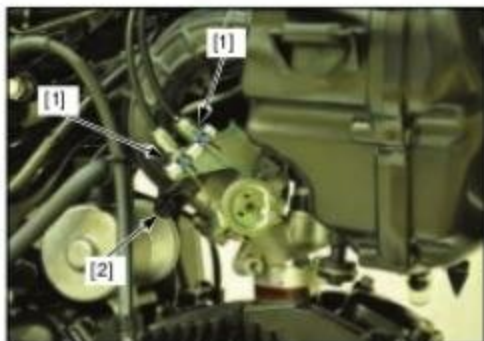

Disconnect the TP sensor connector [1], fuel injector connector [2] and quick connector fitting [3].

Remove the bolts [4] and throttle body.

Installation is in the reverse order of removal.

### NOTE:

If the throttle body is disassembled, or is replaced with a new one, perform the TP sensor reset procedure (page 4-23).

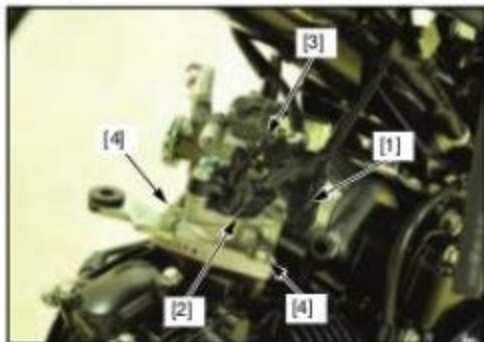

### DISASSEMBLY/ASSEMBLY

- The throttle body is factory pre-set. Do not disassemble in a way other than shown in this manual.
- Do not snap the throttle valve from full open to full close after the throttle cable has been removed. It may cause incorrect idle operation.
- Do not damage the throttle body. It may cause incorrect throttle valve operation.
- Do not loosen or tighten the white painted screw or nut. Removing them can cause throttle body malfunction.

Before removing the idle air screw [1], turn it in carefully to count the number of turns until it seats lightly. Make a note to use as a reference when reinstalling the idle air screw.

**IDLE AIR SCREW STANDARD OPENING:  
2 turns out from the fully seated position**

Remove the following:

- Idle air screw [1], spring and O-ring
- Screw and throttle cable bracket [2]
- Bolts and intake pipe
- Torx screws [3], fast idle solenoid valve [4], spring, valve seat [5] and O-ring

Assemble the throttle body in the reverse order of disassembly.

**TORQUE:**

**Idle solenoid valve torx screw [3]:**

**3.4 N·m (0.3 kgf·m, 2.5 lbf·ft)**

**Throttle cable bracket screw:**

**3.4 N·m (0.3 kgf·m, 2.5 lbf·ft)**

After installation, perform the following:

- Engine idle speed inspection (page 3-8)
- TP sensor reset (page 4-23)

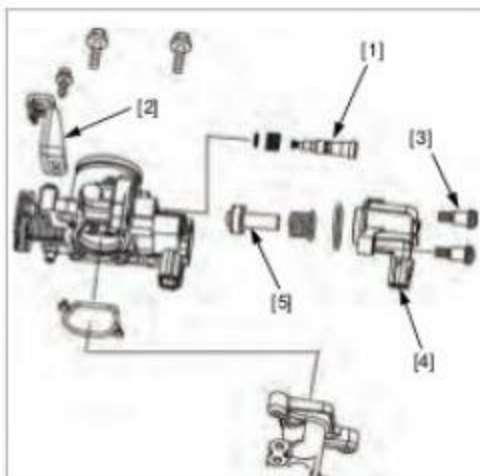

## FUEL INJECTOR

### REMOVAL/INSTALLATION

- Perform the ECM initializing procedure if the fuel injector is replaced with a new one (page 4-24).
- Fuel injector can be serviced with the throttle body installed on the engine.

Remove the right shroud (page 2-4).

Relieve the fuel pressure (page 7-4) and disconnect the fuel injector side quick connect fitting (page 7-5).

Disconnect the fuel injector 2P connector.

Remove the fuel injector joint mounting bolts and fuel injector [1] /fuel injector joint [2] from the intake pipe.

Remove the following from the fuel injector.

- Fuel injector joint [2]
- O-ring [3]
- Seal ring [4]

Check the removed parts for wear or damage and replace them if necessary.

Installation is in the reverse order of removal.

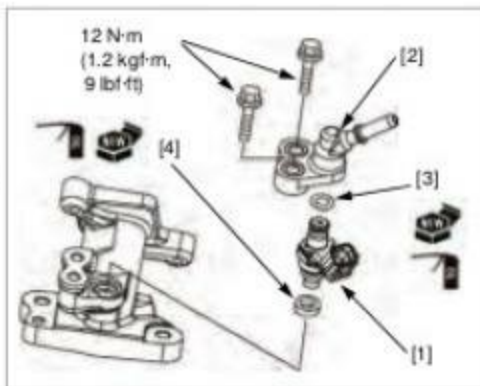

## EVAP PURGE CONTROL SOLENOID VALVE

### REMOVAL/INSTALLATION

Remove the left shroud (page 2-4).

Disconnect the following:

- EVAP purge control solenoid valve 2P (Black) connector [1]
- Vacuum hose [2]
- Canister-to-EVAP purge control solenoid valve hose [3]

Remove the screws [4] and the EVAP purge control solenoid valve [5].

*Route the hoses properly (page 1-15).*

Installation is in the reverse order of removal.

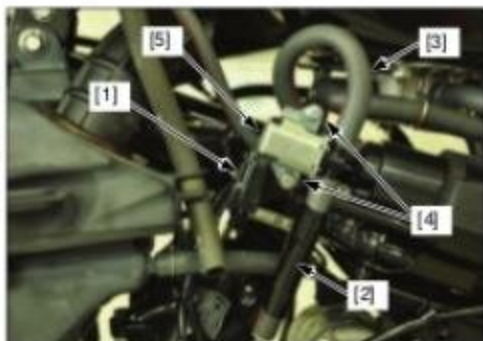

### INSPECTION

Remove the EVAP purge control solenoid valve.

Check that air should flow (A) to (B), only when a 12 V battery is connected to the EVAP purge control solenoid valve terminals.

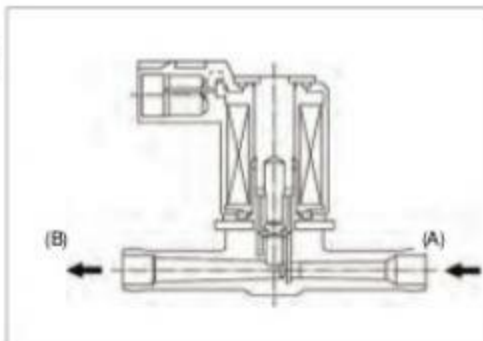

Check the resistance between the terminals of the EVAP purge control solenoid valve [1].

**STANDARD: 30 – 34  $\Omega$  (20 °C/68 °F)**

If the resistance is out of specification, replace the EVAP purge control solenoid valve.

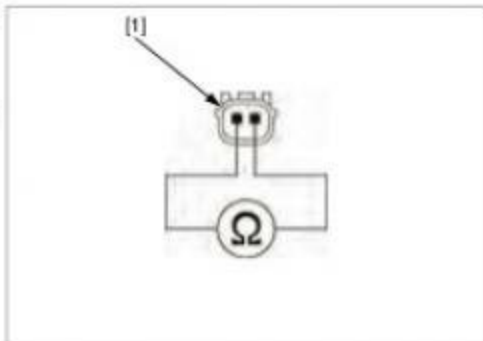

## EVAP CANISTER

### REMOVAL/INSTALLATION

Remove the left shroud (page 2-4).

Disconnect the following:

- Fuel tank breather hose (to fuel tank) [1]
- Canister-to-EVAP purge control solenoid valve hose [2]
- EVAP canister breather hose [3]

Remove the EVAP canister [4] from the frame.

Installation is in the reverse order of removal.

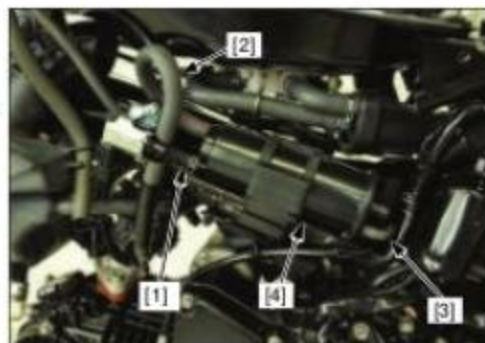

---

**MEMO**

---

## 8. LUBRICATION SYSTEM

---

|                                  |     |                                    |     |
|----------------------------------|-----|------------------------------------|-----|
| SERVICE INFORMATION .....        | 8-2 | OIL PUMP DRIVE GEAR .....          | 8-5 |
| TROUBLESHOOTING.....             | 8-2 | ENGINE OIL STRAINER SCREEN .....   | 8-5 |
| LUBRICATION SYSTEM DIAGRAM ..... | 8-3 | ENGINE OIL CENTRIFUGAL FILTER..... | 8-5 |
| OIL PUMP.....                    | 8-4 |                                    |     |

## LUBRICATION SYSTEM

# SERVICE INFORMATION

## GENERAL

### CAUTION

Used engine oil may cause skin cancer if repeatedly left in contact with the skin for prolonged periods. Although this is unlikely unless you handle used oil on a daily basis, it is still advisable to thoroughly wash your hands with soap and water as soon as possible after handling used oil.

- The oil pump can be serviced with the engine installed in the frame.
- The service procedures in this section must be performed with the engine oil drained.
- When removing and installing the oil pump, use care not to allow dust or dirt to enter the engine.
- If any portion of the oil pump is worn beyond the specified service limits, replace the oil pump as an assembly.
- After the oil pump has been installed, check that there are no oil leaks.

## SPECIFICATIONS

Unit: mm (in)

| ITEM                   |                | STANDARD   | SERVICE LIMIT |
|------------------------|----------------|--|---------------|
| Engine oil capacity    | At draining    | 0.9 liter (0.96 US Qt, 0.20 Imp gal)   | —             |
|                        | At disassembly | 1.1 liters (1.16 US Qt, 0.24 Imp gal)  | —             |
| Recommended engine oil |                | Pro Honda GN4 4-stroke oil (U.S.A. & Canada) or equivalent motorcycle oil<br>API service classification: SG or higher<br>(except oils labeled as energy conserving on the circular API service label)<br>JASO T903 standard: MA<br>Viscosity: SAE 10W-30 | —             |
| Oil pump rotor         | Tip clearance  | —  | 0.15 (0.006)  |
|                        | Body clearance | 0.15 – 0.21 (0.006 - 0.008)  | 0.26 (0.010)  |
|                        | Side clearance | 0.03 – 0.09 (0.001 - 0.004)  | 0.15 (0.006)  |

## TORQUE VALUES

### LUBRICATION SYSTEM

| ITEM                              | Q'TY | THREAD DIA. (mm) | TORQUE N·m (kgf·m, lbf·ft) | REMARKS                             |
|-----------------------------------|------|------------------|----------------------------|-------------------------------------|
| Oil centrifugal filter cover bolt | 3    | 6                | 12 (1.2, 9)                | Apply locking agent to the threads. |
| Oil pump assembly bolt            | 2    | 5                | 5.2 (0.5, 3.8)             |                                     |

## TROUBLESHOOTING

### Engine oil level too low

- Oil consumption
- External oil leak
- Worn piston rings
- Improperly installed piston rings
- Worn valve guide or stem seal
- Worn cylinder

### Oil contamination

- Worn piston rings
- Improperly installed piston rings
- Worn valve guide or stem seal
- Oil not changed frequently enough
- Clogged oil strainer screen

## LUBRICATION SYSTEM DIAGRAM

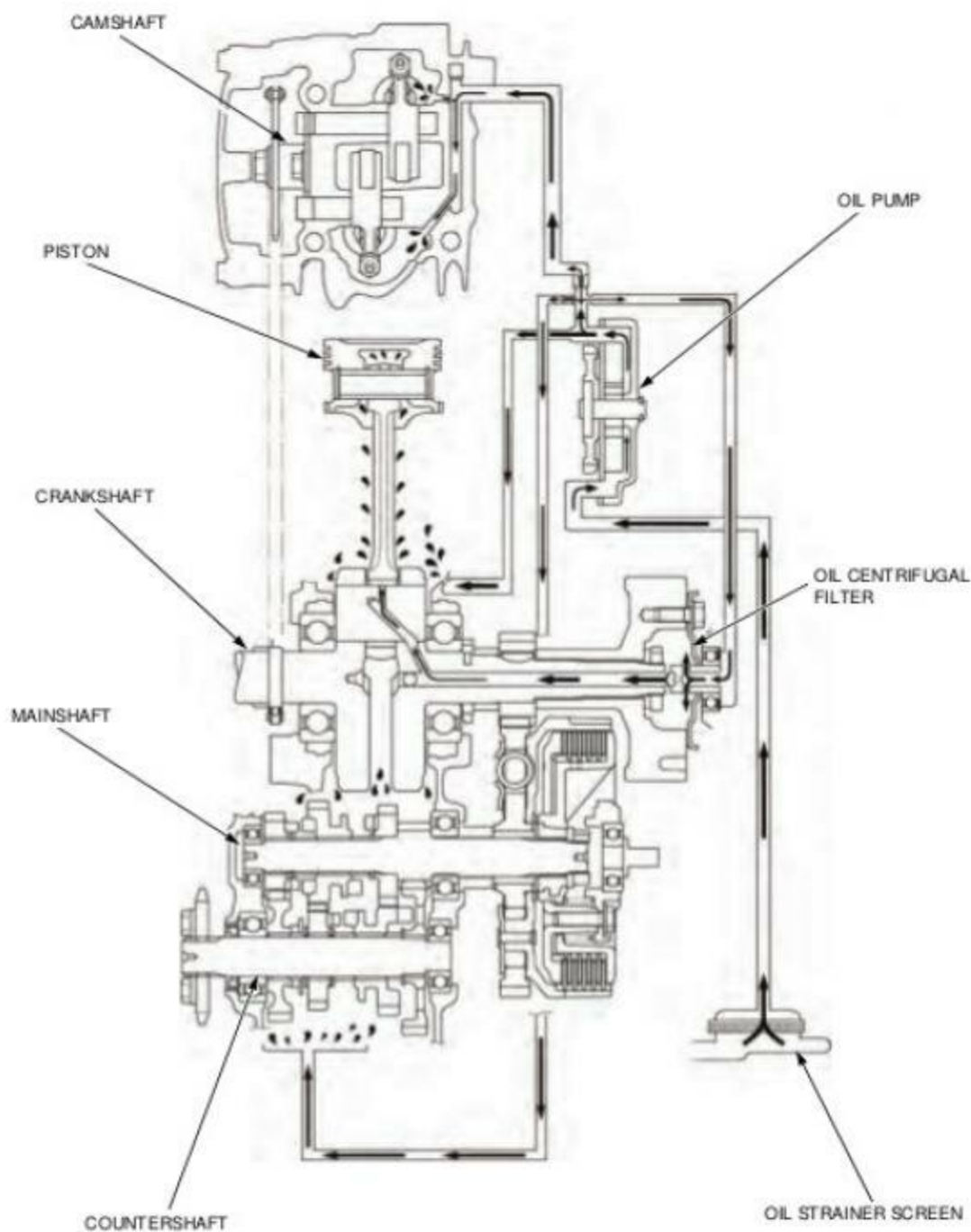

### OIL PUMP

#### REMOVAL/INSTALLATION

Drain the engine oil (page 3-7).

Remove the right crankcase cover (page 11-6).

Remove the bolts [1] and oil pump assembly [2].

Installation is in the reverse order of removal.



#### DISASSEMBLY/ASSEMBLY

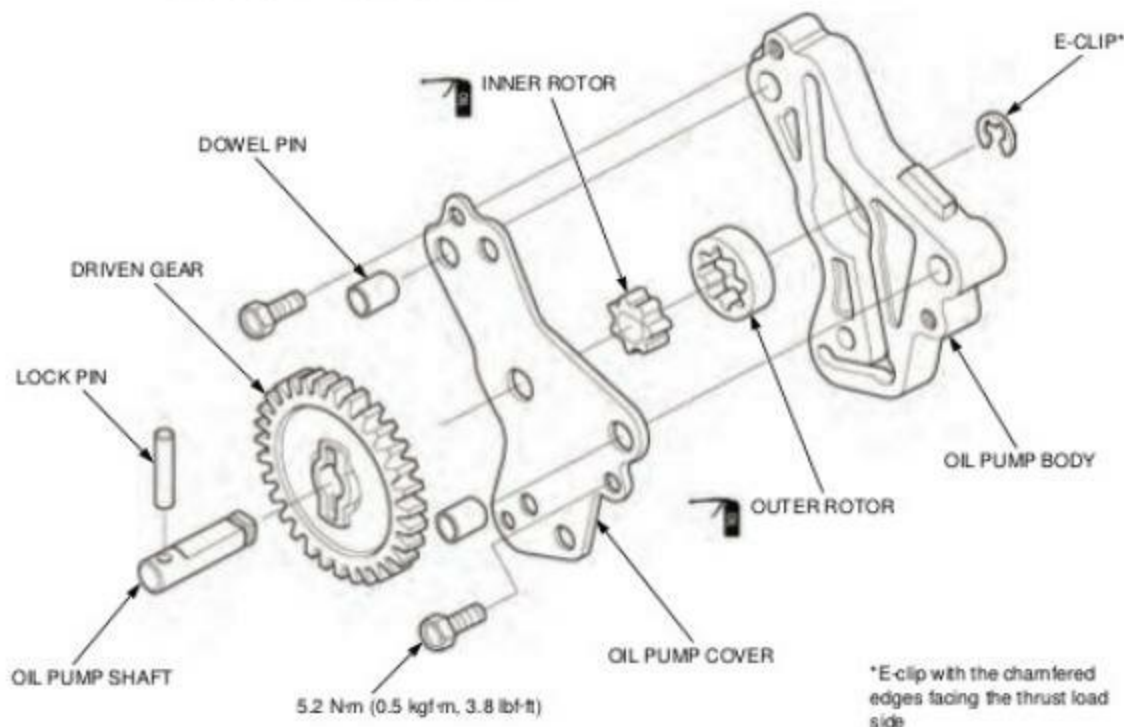

#### INSPECTION

Inspect the following parts for damage, abnormal wear, deformation or burning.

- Oil pump driven gear
- Oil pump shaft
- Lock pin
- Inner rotor
- Outer rotor
- Oil pump body

Measure the oil pump clearances according to LUBRICATION SYSTEM SPECIFICATIONS (page 1-6).

If any of the measurement is out of the service limit, replace the oil pump as an assembly.

## OIL PUMP DRIVE GEAR

### REMOVAL/INSTALLATION

Remove the clutch assembly (page 11-7).

*Be careful not to drop the pin into the crankcase.*

Remove the oil pump drive gear [1] and pin [2]. Check the oil pump drive gear for damage, replace it if necessary.

Installation is in the reverse order of removal.

- Install the oil pump drive gear by aligning the gear groove with the pin.

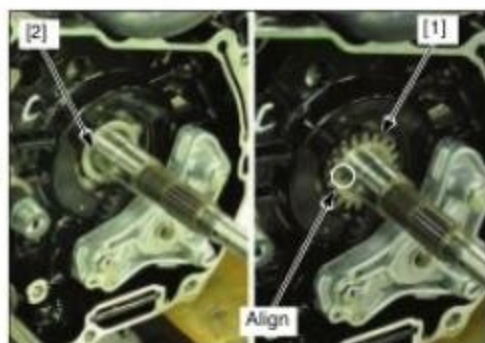

## ENGINE OIL STRAINER SCREEN

Remove the right crankcase cover (page 11-6).

Remove the oil strainer screen [1] and clean it in non-flammable or high flash point solvent.

Install the oil strainer screen with its tapered side facing the crankcase side and thinner edge facing up as shown.

Install the right crankcase cover (page 11-6).

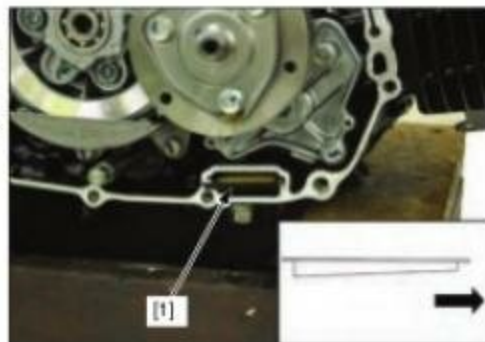

## ENGINE OIL CENTRIFUGAL FILTER

### CLEANING

Remove the right crankcase cover (page 11-6).

Remove the bolts [1], oil centrifugal filter cover [2] and gasket [3].

Clean the oil centrifugal filter cover and inside of the drive plate using a clean lint-free cloth.

Install a new gasket [1] with its sealed side facing the oil centrifugal filter cover.

Apply locking agent to the oil centrifugal filter cover bolt threads as specified.

Install the oil centrifugal filter cover and bolts. Tighten the bolts to the specified torque.

**TORQUE: 12 N·m (1.2 kgf·m, 9 lbf·ft)**

Install the right crankcase cover (page 11-6).

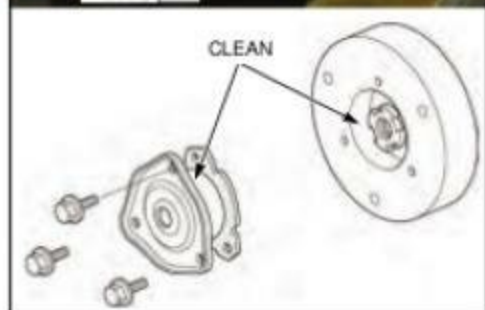
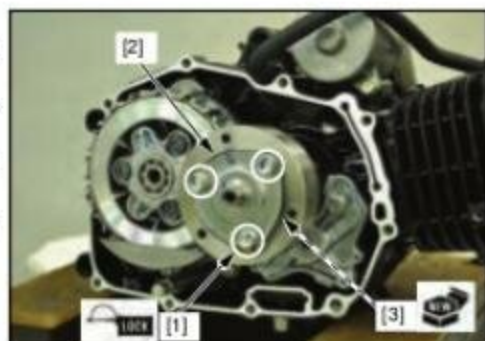

---

**MEMO**

---

## 9. CYLINDER HEAD/VALVES

---

|                                |     |                           |      |
|--------------------------------|-----|---------------------------|------|
| SERVICE INFORMATION .....      | 9-2 | CAMSHAFT/ROCKER ARM ..... | 9-6  |
| TROUBLESHOOTING.....           | 9-4 | CYLINDER HEAD .....       | 9-9  |
| COMPONENT LOCATION .....       | 9-5 | CAM CHAIN TENSIONER ..... | 9-15 |
| CYLINDER COMPRESSION TEST..... | 9-6 |                           |      |

## CYLINDER HEAD/VALVES

### SERVICE INFORMATION

#### GENERAL

- This section covers service of the cylinder head, valves, camshaft and cam chain tensioner.
- The cylinder head, valves, camshaft and cam chain tensioner services can be done with the engine installed in the frame.
- When disassembling, mark and store the disassembled parts to ensure that they are reinstalled in their original locations.
- Clean all disassembled parts with cleaning solvent and dry them by blowing them off with compressed air before inspection.
- Camshaft lubricating oil is fed through oil passages in the cylinder head. Clean the oil passages before assembling cylinder head.
- Be careful not to damage the mating surfaces when removing the cylinder head.

#### SPECIFICATIONS

Unit: mm (in)











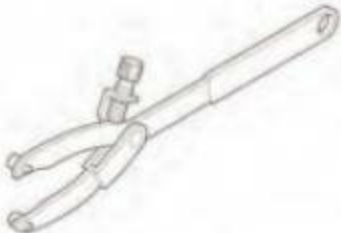

| ITEM                     |                         | STANDARD  |                                   | SERVICE LIMIT  |
|--------------------------|-------------------------|---|-----------------------------------|----------------|
| Cylinder compression     |                         | 1.1 MPa (11.2 kgf/cm <sup>2</sup> , 160 psi) at 600 min <sup>-1</sup> (rpm) |                                   | —              |
| Cylinder head warpage    |                         | —   |                                   | 0.05 (0.002)   |
| Camshaft                 | Cam lobe height         | IN  | 32.657 – 32.897 (1.2857 - 1.2952) | 32.33 (1.2728) |
|                          |                         | EX  | 32.481 – 32.721 (1.2788 - 1.2882) | 31.78 (1.2512) |
| Valve, valve guide       | Valve clearance         | IN  | 0.10 ± 0.02 (0.004 ± 0.001)       | —              |
|                          |                         | EX  | 0.17 ± 0.02 (0.007 ± 0.001)       | —              |
|                          | Valve stem O.D.         | IN  | 4.975 – 4.990 (0.1959 - 0.1965)   | 4.965 (0.1955) |
|                          |                         | EX  | 4.955 – 4.970 (0.1951 - 0.1957)   | 4.945 (0.1947) |
|                          | Valve guide I.D.        | IN/EX   | 5.000 – 5.012 (0.1969 - 0.1973)   | 5.03 (0.198)   |
|                          | Stem-to-guide clearance | IN  | 0.010 – 0.037 (0.0004 - 0.0015)   | 0.065 (0.003)  |
|                          |                         | EX  | 0.030 – 0.057 (0.0012 - 0.0022)   | 0.085 (0.003)  |
|                          | Valve guide projection  | IN/EX   | 10.1 – 10.3 (0.40 - 0.41)         | —              |
| Valve seat width         | IN/EX                   | 1.0 (0.04)  | 1.6 (0.06)                        |                |
| Valve spring free length | IN/EX                   | 33.14 (1.305)   | 31.5 (1.240)                      |                |
| Cam chain tensioner      | Push rod O.D.           | 11.985 – 12.000 (0.4718 - 0.4724)   |                                   | 11.94 (0.470)  |
|                          | Spring free length      | 111.3 (4.38)  |                                   | 109 (4.29)     |

#### TORQUE VALUES

##### CYLINDER HEAD/VALVES

| ITEM                                    | Q'TY | THREAD DIA. (mm) | TORQUE N·m (kgf·m, lbf·ft) | REMARKS  |
|---|------|------------------|----------------------------|--|
| Cylinder head cap bolt                  | 4    | 8                | 24 (2.4, 18)               | Apply engine oil to the threads and seating surface. |
| Cam sprocket bolt                       | 1    | 8                | 27 (2.8, 20)               | Apply engine oil to the threads and seating surface. |
| Tappet adjust nut                       | 2    | 5                | 9.0 (0.9, 6.6)             | Apply engine oil to the threads and seating surface. |
| Cam chain tensioner sealing bolt        | 1    | 14               | 22 (2.2, 16)               |  |
| Cam chain tensioner arm pivot bolt      | 1    | 8                | 16 (1.6, 12)               |  |
| Cam chain guide lower roller pivot bolt | 1    | 6                | 10 (1.0, 7)                |  |
| Timing hole cap                         | 1    | 14               | 6.0 (0.6, 4.4)             |  |
| Crankshaft hole cap                     | 1    | 30               | 8.0 (0.8, 5.9)             |  |

## TOOLS

|   |  |  |
|---|--|--|
| <p>Universal Holder<br/>07725-0030000</p>    | <p>Valve Guide Driver Adjustable Type<br/>07743-0020000</p>   | <p>Valve Spring Compressor Set<br/>07757-0010000</p>   |
| <p>Seat Cutter 27.5 mm<br/>07780-0010200</p>  <p>Equivalent commercially available in the U.S.A.</p> | <p>Seat Cutter 22 mm<br/>07780-0010701</p>  <p>Equivalent commercially available in the U.S.A.</p>      | <p>Flat Cutter 22 mm<br/>07780-0012601</p>  <p>Equivalent commercially available in the U.S.A.</p>      |
| <p>Flat Cutter 27 mm<br/>07780-0013300</p>  <p>Equivalent commercially available in the U.S.A.</p>  | <p>Interior Cutter 22 mm<br/>07780-0014202</p>  <p>Equivalent commercially available in the U.S.A.</p> | <p>Interior Cutter 26 mm<br/>07780-0014500</p>  <p>Equivalent commercially available in the U.S.A.</p> |
| <p>Cutter Holder 5.0 mm<br/>07781-0010400</p>    | <p>Valve Guide Driver 4.8 x 9.7<br/>07942-MA60000</p>   | <p>Valve Spring Compressor Attachment 21mm<br/>07959-KM30101</p>                                      |

## CYLINDER HEAD/VALVES

---

Valve Guide Reamer 5.010  
07984-MA60001



07984-MA6000D (U.S.A. only)

## TROUBLESHOOTING

- Engine top-end problems usually affect engine performance. These problem can be diagnosed by a compression test or by tracing engine noises to the top-end with a sounding rod stethoscope.
- If the performance is poor at low speeds, check for white smoke in the crankcase breather hose. If the hose is smoky, check for a seized piston ring.

### Compression too low, hard starting or poor performance at low speed

- Valves:
  - Incorrect valve clearance
  - Burned or bent valves
  - Incorrect valve timing
  - Broken valve spring
  - Valve stuck open
- Cylinder head:
  - Uneven valve seating
  - Leaking or damaged cylinder head gasket
  - Warped or cracked cylinder head
- Worn cylinder, piston or piston rings

### Compression too high, overheating or knocking

- Excessive carbon build-up on piston head or combustion chamber

### Excessive smoke

- Cylinder head:
  - Worn valve stem or valve guide
  - Damaged stem seal
- Worn cylinder, piston or piston rings

### Excessive noise

- Cylinder head:
  - Incorrect valve clearance
  - Sticking valve or broken valve spring
  - Damaged or worn camshaft
  - Loose or worn cam chain
  - Worn or damaged cam chain guide roller/sprocket
  - Worn or damaged cam chain tensioner
  - Worn cam sprocket teeth
  - Worn rocker arm and/or shaft
  - Faulty cam chain tensioner
- Worn cylinder, piston or piston rings

### Rough idle

- Low cylinder compression
- Faulty fuel system

## COMPONENT LOCATION

24 N·m (2.4 kgf·m, 18 lbf·ft)

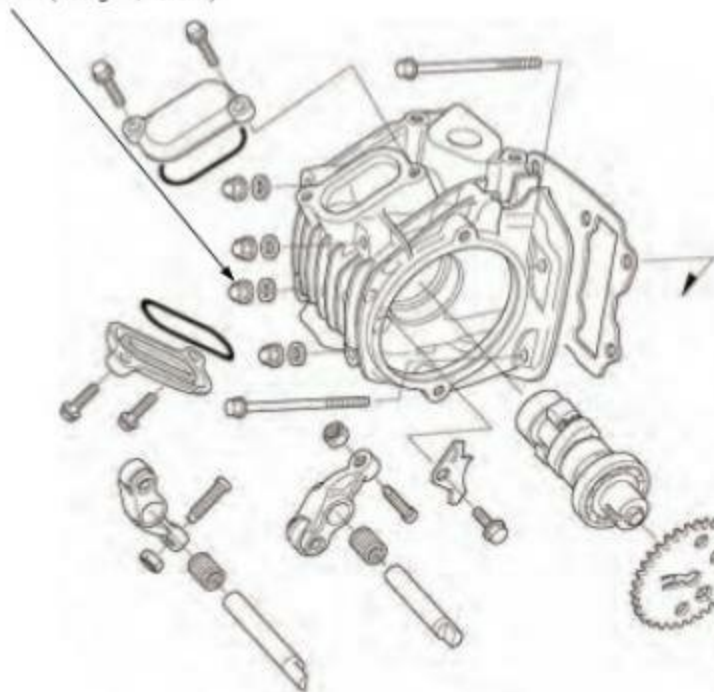

27 N·m (2.8 kgf·m, 20 lbf·ft)

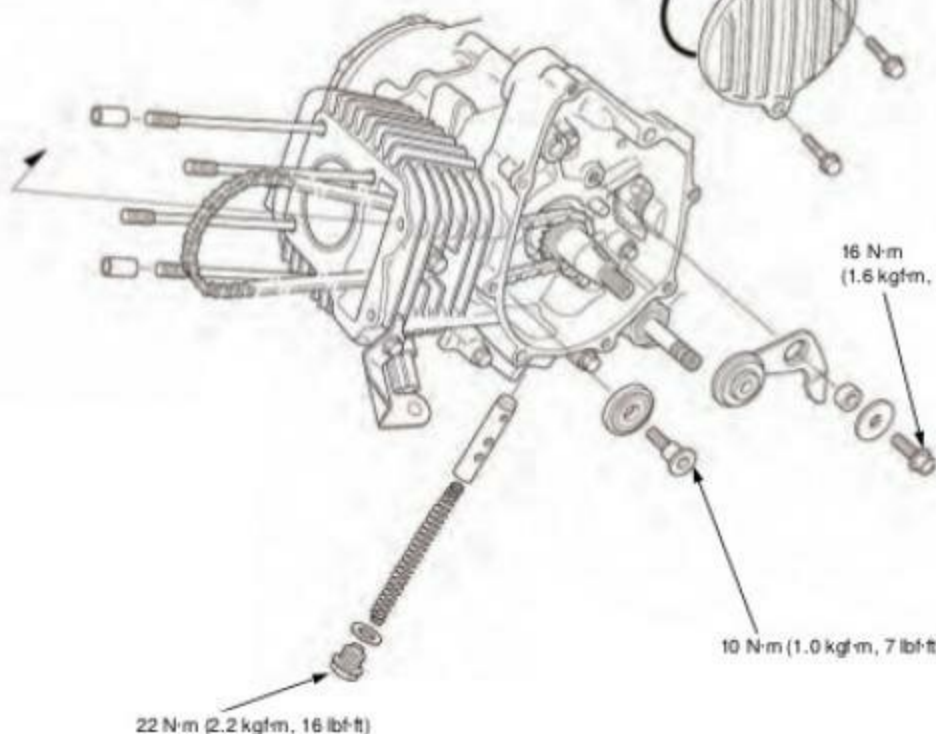
16 N·m  
(1.6 kgf·m, 12 lbf·ft)

10 N·m (1.0 kgf·m, 7 lbf·ft)

22 N·m (2.2 kgf·m, 16 lbf·ft)

## CYLINDER HEAD/VALVES

### CYLINDER COMPRESSION TEST

Warm up the engine to normal operating temperature.

Stop the engine and disconnect the spark plug cap.

Remove the spark plug (page 3-5).

Install the compression gauge [1] in the spark plug hole.

Turn the ignition switch ON.

Shift the transmission into neutral.

Open the throttle all the way and crank the engine with the electric starter until the gauge reading stops rising.

#### STANDARD:

1.1 MPa (11.2 kgf/cm<sup>2</sup>, 160 psi) at 600 min<sup>-1</sup> (rpm)

If compression is high, it indicates that carbon deposits have accumulated on the combustion chamber and/or the piston head.

If compression is low, pour 3 – 5 cc of engine oil into the cylinder through the spark plug hole and recheck the compression.

If the compression increases from the previous value, check the cylinder, piston and piston rings for the following:

- Leaking cylinder head gasket
- Worn piston ring
- Worn cylinder and piston

If the compression is the same as the previous value, check the valves for leakage.

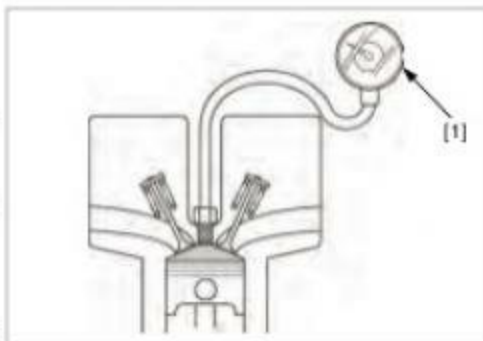

### CAMSHAFT/ROCKER ARM

#### REMOVAL

Remove the Shroud (page 2-4).

Remove the valve adjusting hole caps and set the piston to the TDC (Top Dead Center) on the compression stroke.

Remove the bolt [1] and sealing washer [2].



Remove the bolts [1], cam sprocket cover [2] and O-ring [3].

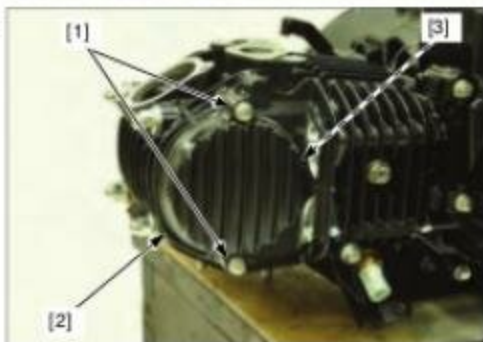

Hold the cam sprocket [1] by using the special tool.

**TOOLS:**

[2] Universal holder

07725-0030000

Remove the washer bolt [3], cam sprocket from the camshaft and cam chain [4] off the cam sprocket.

Attach a piece of wire to the cam chain to prevent it from falling into the crankcase.

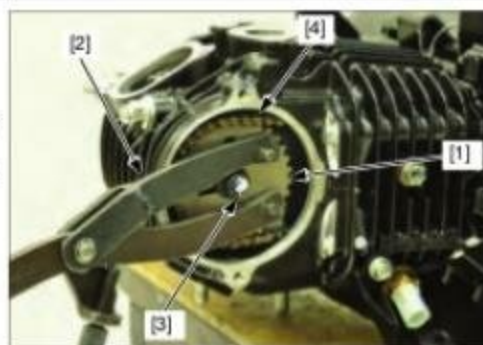

Remove the bolt [1] and rocker arm shaft set plate [2] from the cylinder head.

Remove the rocker arm shafts [3], rocker arms and needle bearings.

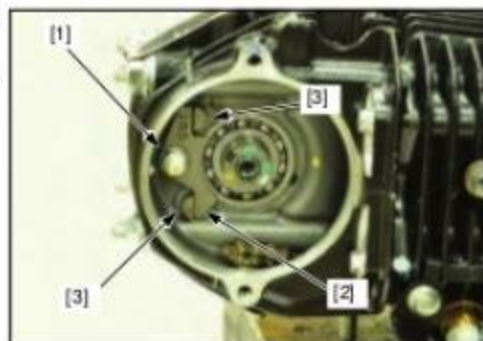

Remove the camshaft [1] from the cylinder head while turning so its groove [2] is facing up as shown.

**INSTALLATION**

Apply engine oil to the camshaft whole surface.

Apply molybdenum disulfide oil to the decompressor cam [3] and arm sliding area.

Install the camshaft into the cylinder head with its groove facing upward as shown.

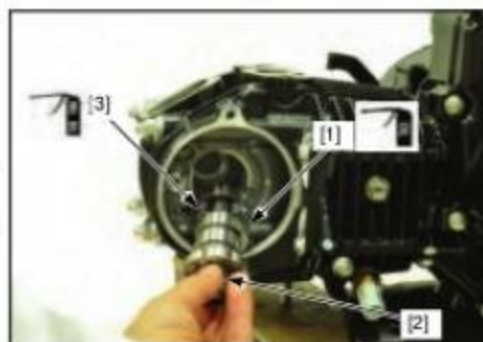

Apply engine oil to the sliding surfaces of the rocker arm shafts [1] and needle bearings [2].

Apply engine oil to the inner surfaces of the rocker arms [3] and sliding surfaces of the rollers [4].

- The exhaust rocker arm shaft is longer than the intake rocker arm shaft.

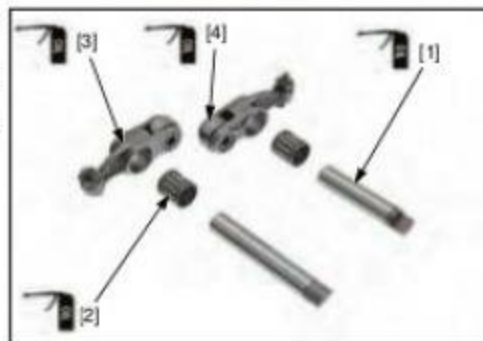

## CYLINDER HEAD/VALVES

Install the rocker arms, needle bearings and rocker arm shafts into the cylinder head.

Install the rocker arm shaft set plate [1] with its "OUT" mark [2] facing out as shown.

Install and tighten the bolt [3].

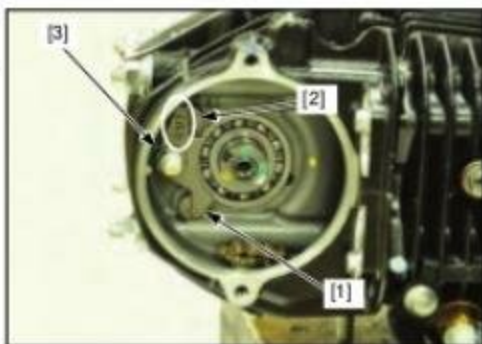

Rotate the crankshaft counterclockwise until the "T" mark [1] on the flywheel is aligned with the index notch [2] on the left crankcase cover.

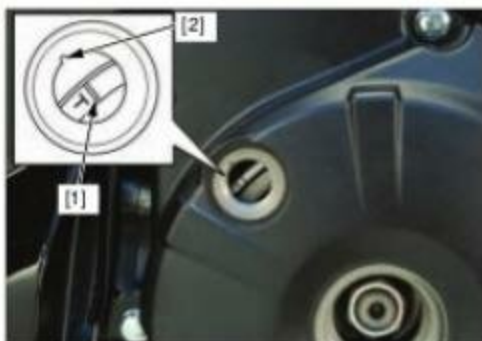

Apply engine oil to the cam chain [1] and cam sprocket [2] teeth.

Install the cam chain on the cam sprocket with its "O" mark [3] facing out as shown by aligning its tab with the groove of the camshaft.

Install the cam sprocket to the camshaft.

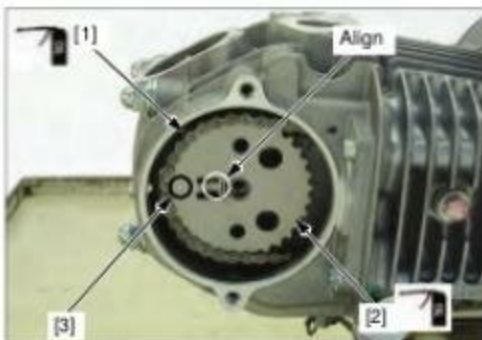

Hold the cam sprocket [1] by using the special tool.

### TOOL:

[2] Universal Holder 07725-0030000

Apply engine oil to the cam sprocket washer bolt [3] threads and seating surface.

Install and tighten the cam sprocket washer bolt to specified torque.

**TORQUE: 27 N·m (2.8 kgf·m, 20 lbf·ft)**

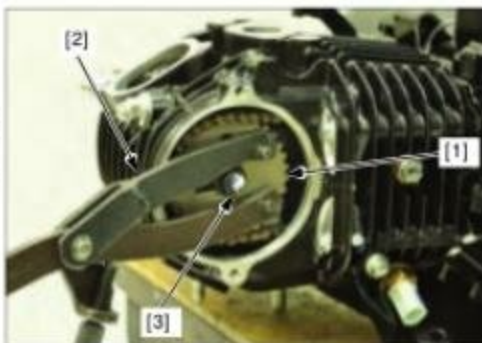

Apply engine oil to a new O-ring [1] and install it into the cam sprocket cover [2] groove.

Install the cam sprocket cover and tighten the bolts [3].

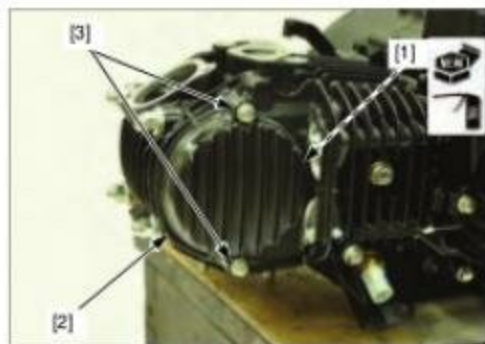

Pour 4.0 cc minimum of engine oil into the push rod.

Install a new sealing washer [1] and bolt [2], then tighten it.

Apply engine oil to the new crankshaft hole cap O-ring and timing hole cap O-ring, then install them to the caps.

Install the crankshaft hole cap and timing hole cap to the left crankcase cover.

#### TORQUE:

**Crankshaft hole cap** 8.0 N·m (0.8 kgf·m, 5.9 lbf·ft)

**Timing hole cap** 6.0 N·m (0.6 kgf·m, 4.4 lbf·ft)

Install the following:

- Valve adjusting hole caps (page 3-6).
- Shroud (page 2-4).

#### INSPECTION

Inspect the following parts for damage, abnormal wear, deformation, burning or clogs in oil passages.

- Rocker arms/shafts/needle bearings
- Cam sprocket
- Camshaft
- Camshaft bearings
- Cam chain guide B
- Cam sprocket
- Decompressor system

Measure each part according to CYLINDER HEAD/VALVES SPECIFICATIONS (page 1-7).

Replace any part if it is out of service limit.

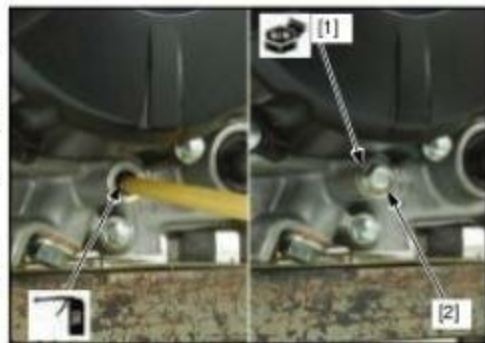

## CYLINDER HEAD

### REMOVAL

Perform the ECM initializing procedure if the cylinder head is replaced or is overhauled (page 4-24).

Remove the following:

- Cam sprocket (page 9-6)
- Exhaust pipe/muffler (page 2-10)
- O<sub>2</sub> sensor cap
- Intake manifold mounting bolts/holder plate/O-ring

Disconnect the spark plug cap.

Remove the cylinder head bolts [1].

Loosen the cylinder head nuts in a crisscross pattern in two or three steps.

Remove the four nuts, sealing washer [2] and three washers [3].

Remove the cylinder head.



## CYLINDER HEAD/VALVES

Remove the gasket [1] and dowel pins [2].

### INSTALLATION

Clean the cylinder and cylinder head mating surface. Install the dowel pins and a new gasket onto the cylinder.

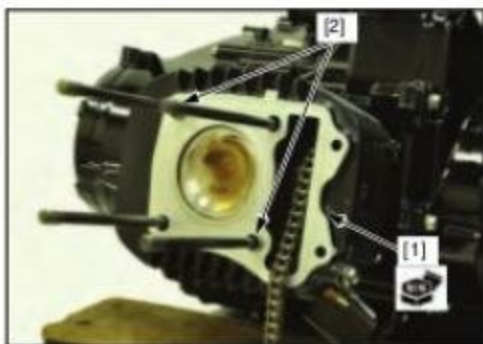

Install the cylinder head onto the cylinder.

Apply engine oil to the seating surface and threads of the cylinder head nuts.

Install new sealing washer [1], three washers [2] and tighten the cylinder head nuts to the specified torque in a crisscross pattern.

**TORQUE: 24 N·m (2.4 kgf·m, 18 lbf·ft)**

Install and tighten the cylinder head mounting bolts [3].

Connect the spark plug cap.

Install the following:

- Cam sprocket (page 9-7)
- Exhaust pipe/muffler (page 2-10)
- O<sub>2</sub> sensor cap
- Intake manifold mounting bolts/holder plate/O-ring

Perform the ECM initializing procedure if the cylinder head is replaced or is overhauled (page 4-24).



### DISASSEMBLY

Remove the following:

- Spark plug (page 3-5)
- Camshaft/rocker arm (page 9-6)
- O<sub>2</sub> sensor

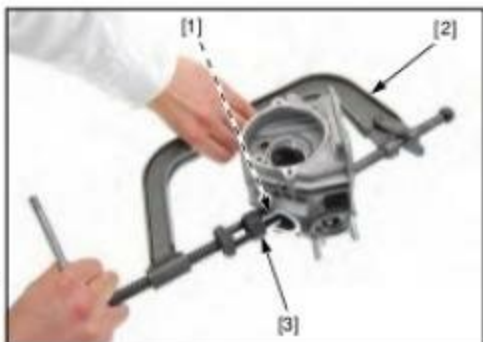

To prevent loss of tension, do not compress the valve springs more than necessary to remove the cotter.

Remove the valve cotter [1] using the special tools.

**TOOLS:**

[2] Valve spring compressor 07757-0010000

[3] Valve spring compressor attachment 07959-KM30101

**attachment**

Mark all parts during disassembly so they can be placed back in their original locations.

Remove the valve spring compressor and remove the following:

- Valve spring retainers
- Valve springs
- Valve spring seats
- Valves
- Valve stem seals

Avoid damaging the mating surface and valve seat surfaces. Remove the carbon deposits from the combustion chamber [1] and clean off the cylinder head gasket surface.



## INSPECTION

Inspect the following parts for damage, abnormal wear, deformation, burning or clogs in oil passages.

- Cylinder head
- Valve spring
- Valves
- Valve guides

Measure each part and clearance according to CYLINDER HEAD/VALVES SPECIFICATIONS (page 1-7).

Replace any part if it is out of service limit.



## ASSEMBLY

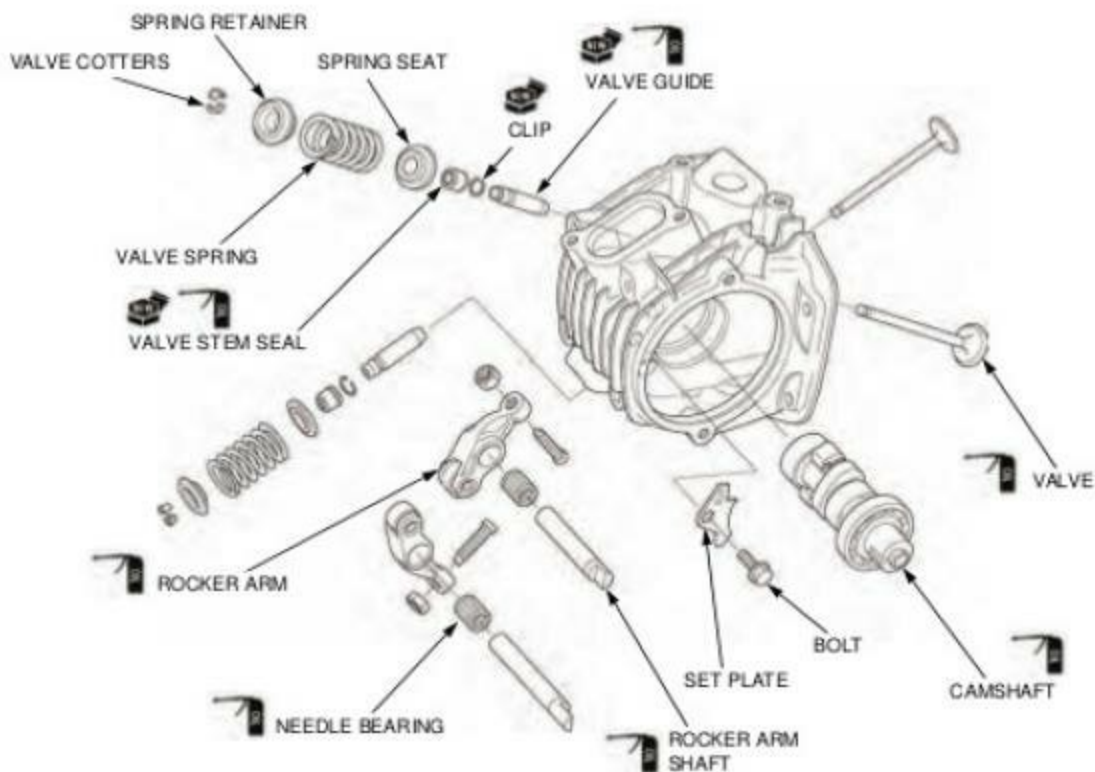

## CYLINDER HEAD/VALVES

Blow through the oil passage in the cylinder head with compressed air.  
Install the valve spring seats [1].  
Apply engine oil to the new valve stem seals [2] and install them.  
Apply engine oil to the valve stem [3] outer surface and stem end.  
Insert the valves into the valve guides while turning them slowly to avoid damage to the valve stem seals.



Install the valve springs with the tightly wound coils facing the combustion chamber.

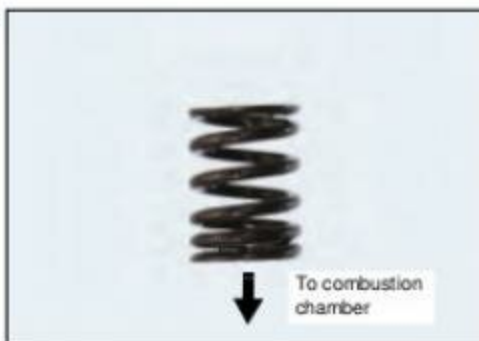

Install the valve spring retainers [1].

*To prevent loss of tension, do not compress the valve spring more than necessary to install the cotters.*

Install the valve cotters [2] using the special tools.

### TOOLS:

[3] Valve spring compressor 07757-0010000  
[4] Valve spring compressor attachment 07959-KM30101



*Support the cylinder head above the work bench surface to prevent valve damage.*

Place a suitable tool [1] onto the valve stem [2].

Tap the tool gently to seat the cotters [3] firmly using a plastic hammer.

Install the following:

- Camshaft/rocker arm (page 9-7)
- Spark plug (page 3-5)
- O<sub>2</sub> sensor (page 4-28)

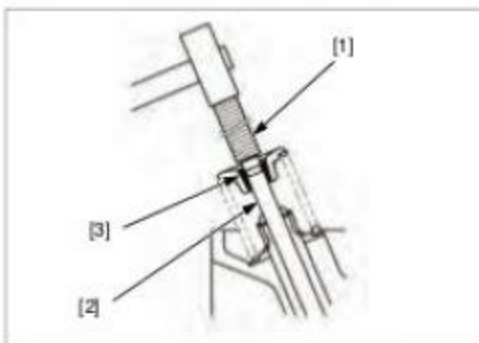

## VALVE GUIDE REPLACEMENT

Chill new valve guides in a freezer for about 1 hour.

## NOTE:

- Be sure to wear heavy gloves to avoid burns when handling the heated cylinder head.
- Using a torch to heat the cylinder head may cause warpage.
- Drive new guides from the camshaft side while the cylinder head is still heated.
- Perform the TP sensor reset/ECM initializing procedure if the valve guide is replaced with a new one.

Heat the cylinder head to 130 – 140°C (275 – 290 °F) with a hot plate or oven. Do not heat the cylinder head beyond 150°C (300°F). Use temperature indicator sticks, available from welding supply stores, to be sure the cylinder head is heated to the proper temperature.

Support the cylinder head and drive the valve guides [1] out of the cylinder head from the combustion chamber side.

## TOOL:

[2] Valve guide driver, 5.0 mm 07942-MA60000

Take out new valve guides from the freezer.

Drive new clips [1] and valve guides [2] into the cylinder head to the specified height from the cylinder head.

## TOOL:

[3] Valve guide adjusting driver 07743-0020000

## VALVE GUIDE PROJECTION:

IN/EX: 10.1 – 10.3 mm (0.40 – 0.41 in)

Let the cylinder head cool to room temperature.

Ream new valve guides after installation.

## NOTE:

- Take care not to tilt or lean the reamer in the guide while reaming.
- Use cutting oil on the reamer during this operation.

Insert the reamer from the combustion chamber side of the cylinder head and always rotate the reamer clockwise.

## TOOL:

[1] Valve guide reamer, 5.0 mm 07984-MA60001  
or 07984-MA6000D  
(U.S.A. only)

Clean the cylinder head thoroughly to remove any metal particles after reaming and reface the valve seat.

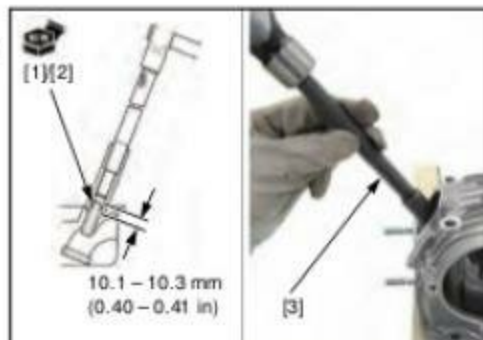
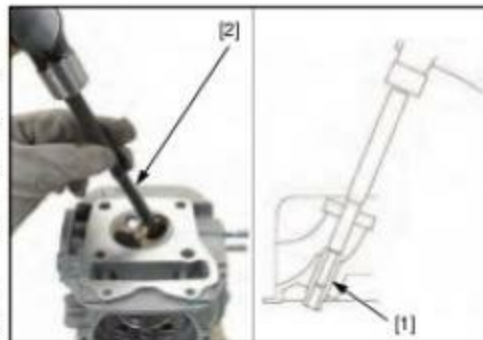

## CYLINDER HEAD/VALVES

### VALVE SEAT INSPECTION/REFACING

#### INSPECTION

Clean the intake and exhaust valves thoroughly to remove carbon deposits.

Apply a light coat of Prussian Blue to the valve seats. Tap the valve against the valve seat several times using a hand-lapping tool [1], without rotating the valve to make a clear pattern.

Remove the valve and inspect the valve seat face width.

Inspect the valve seat face for:

- Damaged face:
  - Replace the valve and reface the valve seat
- Uneven seat width:
  - Bent or collapsed valve stem; Replace the valve and reface the valve seat
- Contact area (too low or too high area):
  - Reface the valve seat

#### REFACING

Reface the valve seat using the following tools.

#### TOOLS:

|                                 |               |
|---------------------------------|---------------|
| Cutter holder, 5.0 mm           | 07781-0010400 |
| Seat cutter, 27.5 mm (45° IN)   | 07780-0010200 |
| Seat cutter, 22 mm (45° EX)     | 07780-0010701 |
| Flat cutter, 27 mm (32° IN)     | 07780-0013300 |
| Flat cutter, 22 mm (32° EX)     | 07780-0012601 |
| Interior cutter, 26 mm (60° IN) | 07780-0014500 |
| Interior cutter, 22 mm (60° EX) | 07780-0014202 |

VALVE SEAT WIDTH: 1.0 mm (0.04 in)

#### NOTE:

- Follow the refacer manufacturer's operating instructions.
  - Be careful not to grind the seat more than necessary.
1. Use a 45° seat cutter, remove any roughness or irregularities from the seat.
  2. Use a 32° flat cutter, remove the top 1/4 of the existing valve seat material.
  3. Use a 60° interior cutter, remove the bottom 1/4 of the existing valve seat material.
  4. Using a 45° seat cutter, cut the seat to the proper width.
  5. After cutting the seat, apply lapping compound to the valve face, and lap the valve using light pressure.

#### NOTE:

- Excessive lapping pressure may deform or damage the seat.
- Change the angle of lapping tool [1] frequently to prevent uneven seat wear.
- Do not allow lapping compound to enter the guides.

After lapping, wash any residual compound off the cylinder head and valve and recheck the seat contact.

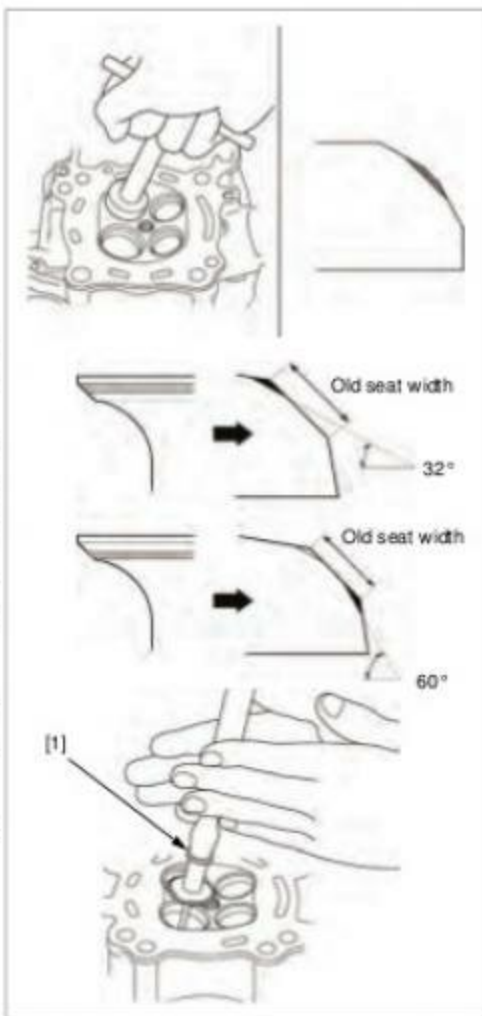

Equivalent  
commercially  
available in the  
U.S.A.

## CAM CHAIN TENSIONER

## REMOVAL

Remove the flywheel (page 12-5).

Remove the following:

- Cam chain tensioner sealing bolt [1] and washer [2]
- Tensioner spring [3]
- Push rod [4]



Remove the following:

- Pivot bolt/washer [1]
- Tensioner arm/upper roller [2] and collar [3]
- Bolt [4] and lower roller [5]

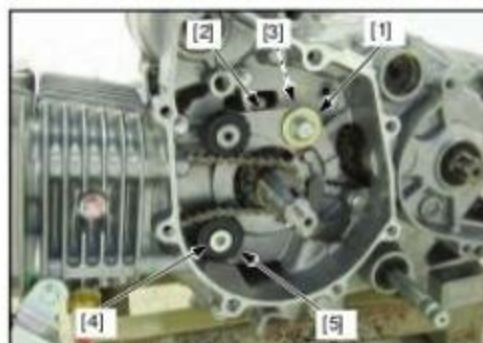

## INSTALLATION

Install the cam chain tensioner lower roller [1] and tighten the pivot bolt [2] to the specified torque.

**TORQUE: 10 N·m (1.0 kgf·m, 7 lbf·ft)**

Install the cam chain tensioner arm/upper roller [3], collar [4], and pivot bolt/washer [5], then tighten it to the specified torque.

**TORQUE: 16 N·m (1.6 kgf·m, 12 lbf·ft)**



Install the following:

- Push rod [1]
- Tensioner spring [2]

Install and tighten the sealing bolt [3] with a new sealing washer [4] to the specified torque.

**TORQUE: 22 N·m (2.2 kgf·m, 16 lbf·ft)**



## CYLINDER HEAD/VALVES

---

Remove the bolt [1] and sealing washer [2].  
Pour 4.0 cc minimum of engine oil into the push rod.  
Install and tighten the bolt with a new sealing washer.  
Install the flywheel (page 12-6).

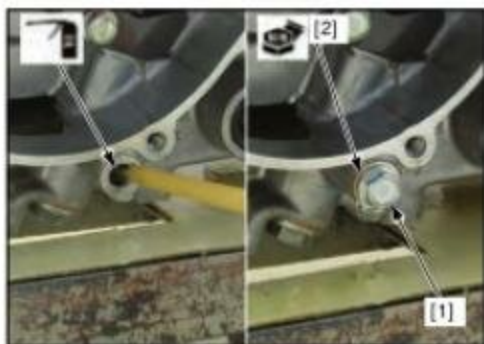

### INSPECTION

Inspect the following parts for damage, abnormal wear, deformation, burning or dogs in oil passages.

- Tensioner spring
- Push rod/check valve
- Valves
- Valve guides

Measure each part and clearance according to CYLINDER HEAD/VALVES SPECIFICATIONS (page 1-7).

Replace any part if it is out of service limit.

|  |       |  |           |
|--|-------|--|-----------|
| AIR CLEANER.....                                       | 3-4   | HANDLEBAR SWITCHES.....                                | 19-9      |
| AIR CLEANER HOUSING                                    |       | HEADLIGHT.....   | 2-7, 19-4 |
| FUEL SYSTEM.....                                       | 7-7   | HEADLIGHT AIM.....                                     | 3-12      |
| ALTERNATOR CHARGING COIL.....                          | 18-6  | HORN.....  | 19-5      |
| ALTITUDE SETTING.....                                  | 4-25  | IGNITION COIL  |           |
| BANK ANGLE SENSOR.....                                 | 4-27  | IGNITION SYSTEM.....                                   | 5-7       |
| BATTERY.....   | 18-5  | IGNITION SWITCH.....                                   | 19-8      |
| BODY COVER/TAIL COVER.....                             | 2-6   | IGNITION SYSTEM INSPECTION                             |           |
| BRAKE FLUID.....                                       | 3-11  | IGNITION SYSTEM.....                                   | 5-5       |
| BRAKE FLUID REPLACEMENT/AIR BLEEDING.....              | 17-5  | IGNITION TIMING  |           |
| BRAKE LIGHT SWITCH                                     |       | IGNITION SYSTEM.....                                   | 5-8       |
| LIGHTS/METERS/SWITCHES.....                            | 19-9  | LEFT CRANKCASE COVER.....                              | 12-4      |
| MAINTENANCE.....                                       | 3-12  | LICENSE LIGHT.....                                     | 19-5      |
| BRAKE PAD/DISC.....                                    | 17-7  | LUBRICATION & SEAL POINTS.....                         | 1-13      |
| BRAKE PADS WEAR.....                                   | 3-10  | LUBRICATION SYSTEM DIAGRAM.....                        | 8-3       |
| BRAKE PEDAL.....                                       | 17-14 | MAINTENANCE SCHEDULE.....                              | 3-3       |
| BRAKE SYSTEM.....                                      | 3-11  | MIL CIRCUIT INSPECTION.....                            | 4-22      |
| BRAKE/TAILLIGHT.....                                   | 19-4  | MIL CODE INDEX.....                                    | 4-9       |
| CABLE & HARNESS ROUTING.....                           | 1-15  | MIL TROUBLESHOOTING.....                               | 4-10      |
| CAM CHAIN TENSIONER.....                               | 9-15  | MODEL IDENTIFICATION.....                              | 1-3       |
| CAMSHAFT/ROCKER ARM.....                               | 9-6   | NEUTRAL SWITCH.....                                    | 19-10     |
| CHARGING SYSTEM INSPECTION.....                        | 18-5  | NUTS, BOLTS, FASTENERS.....                            | 3-14      |
| CLUTCH.....  | 11-7  | O2 SENSOR.....   | 4-28      |
| CLUTCH SYSTEM.....                                     | 3-12  | OIL PUMP.....  | 8-4       |
| COMPONENT LOCATION                                     |       | OIL PUMP DRIVE GEAR.....                               | 8-5       |
| ALTERNATOR/STARTER CLUTCH.....                         | 12-3  | PGM-FI SYMPTOM TROUBLESHOOTING.....                    | 4-5       |
| CLUTCH/GEARSHIFT LINKAGE.....                          | 11-5  | PGM-FI TROUBLESHOOTING INFORMATION.....                | 4-6       |
| CRANKCASE/TRANSMISSION/KICKSTARTER/<br>CRANKSHAFT..... | 13-5  | REAR BRAKE CALIPER.....                                | 17-13     |
| CYLINDER HEAD/VALVES.....                              | 9-5   | REAR FENDER A.....                                     | 2-8       |
| ENGINE REMOVAL/INSTALLATION.....                       | 14-3  | REAR FENDER B.....                                     | 2-9       |
| FRONT WHEEL/SUSPENSION/STEERING.....                   | 15-5  | REAR MASTER CYLINDER.....                              | 17-9      |
| HYDRAULIC BRAKE.....                                   | 17-4  | REAR UNDER COVER.....                                  | 2-7       |
| REAR WHEEL/SUSPENSION.....                             | 16-4  | REAR WHEEL.....  | 16-5      |
| CRANKCASE.....   | 13-6  | REGULATOR/RECTIFIER.....                               | 18-7      |
| CRANKCASE BREATHER.....                                | 3-5   | RIGHT CRANKCASE COVER.....                             | 11-6      |
| CRANKSHAFT.....  | 13-7  | SEAT.....  | 2-3       |
| CYLINDER COMPRESSION TEST.....                         | 9-6   | SERVICE INFORMATION                                    |           |
| CYLINDER HEAD.....                                     | 9-9   | ALTERNATOR STARTER CLUTCH.....                         | 12-2      |
| CYLINDER/PISTON.....                                   | 10-3  | BATTERY/CHARGING SYSTEM.....                           | 18-2      |
| DRIVE CHAIN.....                                       | 3-9   | BODY PANELS/EXHAUST SYSTEM.....                        | 2-2       |
| DRIVE CHAIN COVER.....                                 | 2-9   | CLUTCH/GEARSHIFT LINKAGE.....                          | 11-2      |
| ECM.....   | 4-26  | CRANKCASE/TRANSMISSION/KICKSTARTER/<br>CRANKSHAFT..... | 13-2      |
| ECM INITIALIZING PROCEDURE.....                        | 4-24  | CYLINDER HEAD/VALVES.....                              | 9-2       |
| EMISSION CONTROL SYSTEMS.....                          | 1-25  | CYLINDER/PISTON.....                                   | 10-2      |
| ENGINE IDLE SPEED.....                                 | 3-8   | ELECTRIC STARTER SYSTEM.....                           | 6-2       |
| ENGINE OIL.....  | 3-7   | ENGINE REMOVAL/INSTALLATION.....                       | 14-2      |
| ENGINE OIL CENTRIFUGAL FILTER.....                     | 8-5   | FRONT WHEEL/SUSPENSION/STEERING.....                   | 15-2      |
| ENGINE OIL STRAINER SCREEN.....                        | 8-5   | FUEL SYSTEM.....                                       | 7-2       |
| ENGINE REMOVAL.....                                    | 14-4  | HYDRAULIC BRAKE.....                                   | 17-2      |
| EOT SENSOR.....  | 4-27  | IGNITION SYSTEM.....                                   | 5-2       |
| EVAP CANISTER.....                                     | 7-11  | LIGHTS/METERS/SWITCHES.....                            | 19-2      |
| EVAP PURGE CONTROL SOLENOID VALVE.....                 | 7-10  | LUBRICATION SYSTEM.....                                | 8-2       |
| EXHAUST PIPE/MUFFLER.....                              | 2-10  | MAINTENANCE.....                                       | 3-2       |
| FLYWHEEL/STARTER CLUTCH.....                           | 12-5  | PGM-FI SYSTEM.....                                     | 4-2       |
| FORK.....  | 15-8  | REAR WHEEL/SUSPENSION.....                             | 16-2      |
| FRONT BRAKE CALIPER.....                               | 17-11 | SERVICE RULES.....                                     | 1-2       |
| FRONT FENDER.....                                      | 2-3   | SHOCK ABSORBER.....                                    | 16-7      |
| FRONT MASTER CYLINDER.....                             | 17-8  | SHROUD.....  | 2-4       |
| FRONT WHEEL.....                                       | 15-6  | SIDESTAND  |           |
| FUEL GAUGE/FUEL LEVEL SENSOR.....                      | 19-7  | MAINTENANCE.....                                       | 3-13      |
| FUEL INJECTOR.....                                     | 7-9   | SIDESTAND SWITCH.....                                  | 19-10     |
| FUEL LINE INSPECTION.....                              | 7-3   | SPARK PLUG.....  | 3-5       |
| FUEL PUMP UNIT.....                                    | 7-5   | SPECIFICATIONS.....                                    | 1-5       |
| FUEL TANK  |       | SPEEDOMETER.....                                       | 19-6      |
| FUEL SYSTEM.....                                       | 7-4   | STARTER MOTOR.....                                     | 6-4       |
| FUEL TANK COVER.....                                   | 2-6   | STARTER RELAY.....                                     | 6-9       |
| GEARSHIFT LINKAGE.....                                 | 11-10 | STATOR.....  | 12-4      |
| HANDLEBAR.....   | 15-16 | STEERING HEAD BEARINGS.....                            | 3-14      |

## INDEX

---

|                                 |       |                                       |       |
|---------------------------------|-------|---------------------------------------|-------|
| STEERING STEM .....             | 15-20 | TROUBLESHOOTING                       |       |
| SUSPENSION .....                | 3-13  | BATTERY/CHARGING SYSTEM .....         | 18-3  |
| SWINGARM .....                  | 16-8  | BODY PANELS/EXHAUST SYSTEM .....      | 2-2   |
| SYSTEM DIAGRAM                  |       | CLUTCH/GEARSHIFT LINKAGE .....        | 11-4  |
| BATTERY/CHARGING SYSTEM .....   | 18-4  | CRANKCASE/TRANSMISSION/KICKSTARTER/   |       |
| ELECTRIC STARTER SYSTEM .....   | 6-3   | CRANKSHAFT .....                      | 13-4  |
| IGNITION SYSTEM .....           | 5-4   | CYLINDER HEAD/VALVES .....            | 9-4   |
| PGM-FI SYSTEM .....             | 4-4   | CYLINDER/PISTON .....                 | 10-2  |
| SYSTEM LOCATION                 |       | ELECTRIC STARTER SYSTEM .....         | 6-2   |
| BATTERY/CHARGING SYSTEM .....   | 18-4  | FRONT WHEEL/SUSPENSION/STEERING ..... | 15-4  |
| ELECTRIC STARTER SYSTEM .....   | 6-3   | HYDRAULIC BRAKE .....                 | 17-3  |
| IGNITION SYSTEM .....           | 5-4   | IGNITION SYSTEM .....                 | 5-3   |
| LIGHTS/METERS/SWITCHES .....    | 19-3  | LUBRICATION SYSTEM .....              | 8-2   |
| PGM-FI SYSTEM .....             | 4-3   | REAR WHEEL/SUSPENSION .....           | 16-3  |
| TECHNICAL FEATURES .....        | 1-23  | TURN SIGNAL LIGHT .....               | 19-4  |
| THROTTLE BODY .....             | 7-8   | TURN SIGNAL RELAY .....               | 19-11 |
| THROTTLE OPERATION .....        | 3-4   | VALVE CLEARANCE .....                 | 3-6   |
| TORQUE VALUES .....             | 1-10  | VS SENSOR .....                       | 19-11 |
| TP SENSOR RESET PROCEDURE ..... | 4-23  | WHEELS/TIRES .....                    | 3-14  |
| TRANSMISSION .....              | 13-10 | WIRING DIAGRAM .....                  | 20-2  |

---

---

**MEMO**

---

---

**MEMO**

---

